

1442543F4-C

ADTRAN® 1442543F4 Compatible TAA Combo PON OLT SFP+ Transceiver (SMF, 1577nmTx/1270nmRx and 1490nmTx/1310nmRx, D, SC, DOM)

Features:

- SFF-8472 Compliant
- ITU-T G.9807.1 and ITU-T G.987.2 Compliant
- Single Fiber Bi-Directional Data Links Tx 9.953Gbps, Burst Mode Rx 9.953G/2.488Gbps Application
- Single Fiber Bi-Directional Data Links Tx 2.488Gbps, Burst Mode Rx 1.244Gbps Application
- SC UPC Receptacle Connector
- Single-Mode Fiber
- SD Indication
- Commercial Temperature: 0 to 70 Celsius
- RoHS Compliant and Lead-Free

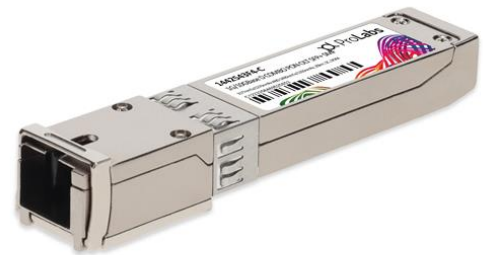

Applications:

- XGS-PON Class D OLT
- GPON OLT Class D OLT

Product Description

This ADTRAN® 1442543F4 Compatible Combo PON OLT class D SFP+ transceiver provides 1G/10GBase throughput up to 20km over single-mode fiber (SMF) using a wavelength of 1577nmTx/1270nmRx and 1490nmTx/1310nmRx via an SC connector. It can operate at temperatures between 0 and 70C. This product is in compliance with Multi-Source Agreement (MSA) standards to provide seamless network integration. Additional product features include Digital Optical Monitoring (DOM) support which allows access to real-time operating parameters. This transceiver is Trade Agreements Act (TAA) compliant. We stand behind the quality of our products and proudly offer a limited lifetime warranty.

ProLabs' transceivers are RoHS compliant and lead-free.

TAA refers to the Trade Agreements Act (19 U.S.C. & 2501-2581), which is intended to foster fair and open international trade. TAA requires that the U.S. Government may acquire only "U.S.-made or designated country end products."



Absolute Maximum Ratings

Parameter	Symbol	Min.	Typ.	Max.
Vcc3 Power Supply Voltage	Vcc3	3.13	3.47	V
Storage Ambient Temperature	Tstg	-40	85	°C
Operating Case Temperature	Tc	0	70	°C
Relative Storage Humidity	RHstg	5	85	%
Relative Operating Humidity	RHop	5	85	%

XGSPON/XGPON Electrical Characteristics

Parameter	Symbol	Min.	Typ.	Max.	Unit	Notes
Power Supply Voltage	Vcc	3.13	3.3	3.47	V	
Total Power				3.3	W	
XGSPON Transmitter						
Data Input Differential Swing		100		850	mV	1
Input Differential Impedance	ZIN	90	100	110	Ω	
Tx_Disable	Disable	2		Vcc+0.3	V	
	Enable	0		0.8	V	
Tx_Fault	Fault	2.4		Vcc+0.3	V	
	Normal	0		0.4	V	
Eye Mask Definitions: (X3-X2, Y1, Y2, Y3, Y4)		(0.2, 0.25, 0.75, 0.25, 0.25)			UI	2
XGSPON/XGPON Receiver						
Guard Time	Tg	50	100		ns	
Reset Pulse Width	Tr	25.6			ns	
Receiver Threshold Settling Time	T _{SETTLING}			100	ns	3
Data Output Differential Swing		400		800	mV	4
Output Differential Impedance	ZOUT	90	100	110	Ω	
SD Assert Level Time				100	ns	
SD De-Assert Level Time				100	ns	
SD Voltage – Low		0		0.4	V	
SD Voltage – High		2.4		Vcc+0.3	V	

Notes:

1. CML input. AC coupled.

2. Test procedure for eye mask:

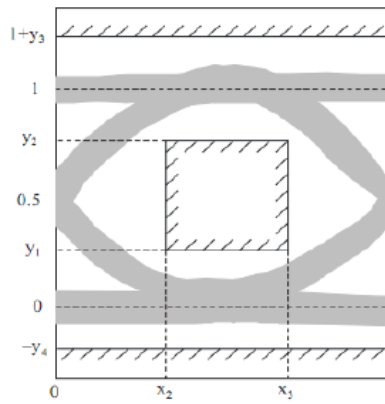

3. Timing parameter definitions in XGSPON burst mode sequence:

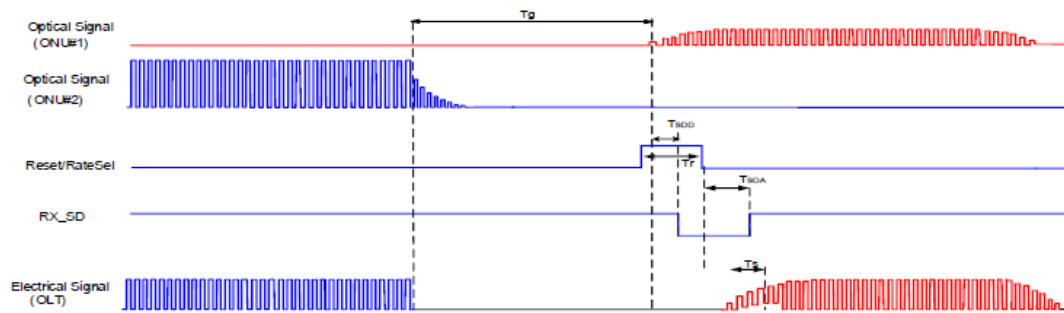

4. DC coupled. CML output.

GPON Electrical Characteristics

Parameter	Symbol	Min.	Typ.	Max.	Unit	Notes
Power Supply Voltage	Vcc	3.13	3.3	3.47	V	
Total Power				3.3	W	
GPON Transmitter						
Data Input Differential Swing		100		850	mV	1
Input Differential Impedance	ZIN	90	100	110	Ω	
Tx_Disable	Disable	2		Vcc+0.3	V	
	Enable	0		0.8	V	
Tx_Fault	Fault	2.4		Vcc+0.3	V	
	Normal	0		0.4	V	
Eye Mask Definitions: (X3-X2, Y1, Y2)			(0.2, 0.25, 0.75)		UI	2
GPON Receiver						
Guard Time	Tg	25.6	50		ns	
Reset Pulse Width	Tr	12.8			ns	
Receiver Threshold Settling Time	T _{SETTLING}		25.6		ns	3
Data Output Differential Swing		600		1600	mV	4
Output Differential Impedance	ZOUT	90	100	110	Ω	
SD Assert Level Time	Ta			24	ns	3
SD De-Assert Level Time				25.6	ns	
SD Voltage – Low		0		0.4	V	
SD Voltage – High		2.4		Vcc+0.3	V	

Notes:

1. CML input. AC coupled.
2. Test procedure for eye mask:

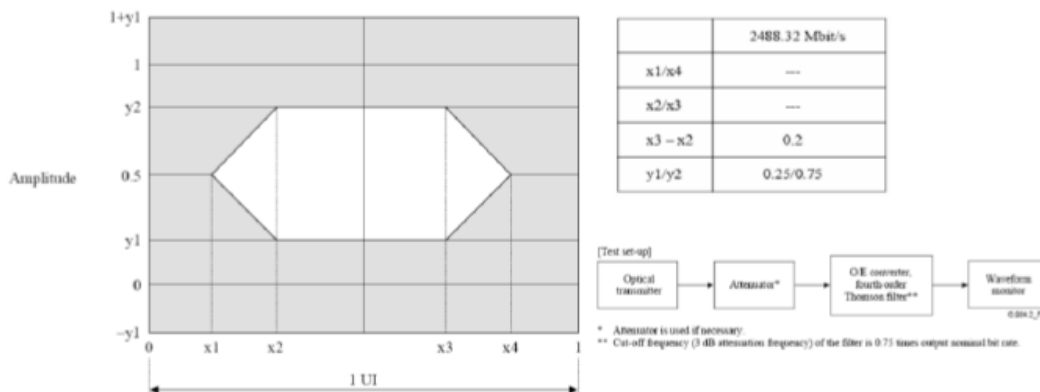

3. Timing parameter definitions in GPON burst mode sequence:

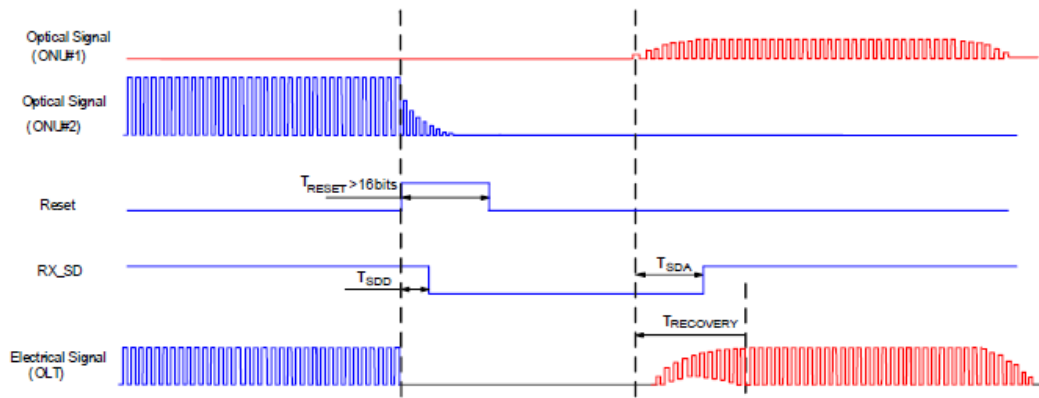

4. LVPECL output. DC coupled.

XGSPON/XGPON Optical Characteristics

Parameter	Symbol	Min.	Typ.	Max.	Unit	Notes
XGSPON Transmitter						
Tx Data Rate			9.953		Gbps	
Optical Center Wavelength	λ_C	1575		1580	nm	
Optical Spectrum Width (-20dB)	$\Delta\lambda$			1	nm	
Side-Mode Suppression Ratio	SMSR	30			dB	
Average Launch Optical Power	P_{avg}	+8		+11	dBm	1
Power-Off Transmitter Optical Power				-39	dBm	1
Extinction Ratio	ER	8.2			dB	2
Optical Waveform Diagram		Compliant with ITU-T G.9807.1				3
Tolerance to Transmitter Incident Light Power		-15			dB	
Transmitter and Dispersion Penalty	TDP			1	dB	4
XGSPON Receiver						
Rx Data Rate			9.953		Gbps	
Operating Wavelength	λ_C	1260		1280	nm	
Sensitivity	SEN			-32.0	dBm	5
Minimum Overload		-11			dBm	5
Maximum Optical Input				0	dBm	5
SD Assert Level				-32.5	dBm	
SD De-Assert Level		-43			dBm	
Hysteresis		0.5		6	dB	
Receiver Reflectance				-12	dB	
XGPON Receiver						
Rx Data Rate			2.488		Gbps	
Operating Wavelength	λ_C	1260		1280	nm	
Sensitivity	SEN			-33.5	dBm	6
Minimum Overload		-13			dBm	6
Maximum Optical Input				0	dBm	6
SD Assert Level				-34.0	dBm	
SD De-Assert Level		-43			dBm	
Hysteresis		0.5		6	dB	
Receiver Reflectance				-12	dB	

Notes:

1. Launched into SMF.
2. PRBS 2³¹ @9.953Gbps.

3. Mask margin is >5%. XGSPON transmitter eye mask definitions:

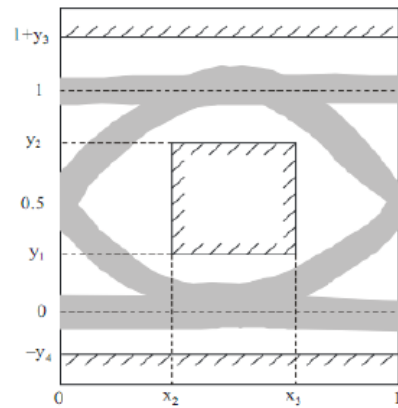

4. Transmit on 20KM SMF.
5. $ER \geq 6\text{dB}$, PRBS 2^{31} , @9.953Gbps, and $BER \leq 1 \times 10^{-3}$.
6. $ER \geq 6\text{dB}$, PRBS 2^{23} , @2.488Gbps, and $BER \leq 1 \times 10^{-4}$.

GPON Optical Characteristics

Parameter	Symbol	Min.	Typ.	Max.	Unit	Notes
GPON Transmitter						
Tx Data Rate			2.488		Gbps	
Optical Center Wavelength	λ_C	1480		1500	nm	
Optical Spectrum Width (-20dB)	$\Delta\lambda$			1	nm	
Side-Mode Suppression Ratio	SMSR	30			dB	
Average Launch Optical Power	P_{avg}	+6		+10	dBm	1
Power-Off Transmitter Optical Power				-39	dBm	1
Extinction Ratio	ER	8.2			dB	2
Optical Waveform Diagram		Compliant with ITU-T G.984.2				3
Tolerance to Transmitter Incident Light Power		-15			dB	
Transmitter and Dispersion Penalty	TDP			1	dB	4
GPON Receiver						
Rx Data Rate			1.244		Gbps	
Operating Wavelength	λ_C	1290	1310	1330	nm	
Sensitivity	SEN			-35.0	dBm	5
Minimum Overload		-15			dBm	5
Maximum Optical Input				0	dBm	5
SD Assert Level				-35.5	dBm	
SD De-Assert Level		-43			dBm	
Hysteresis		0.5		6	dB	
CID		72			bit	

Notes:

1. Launched into SMF.
2. PRBS 2^{23} @2.488Gbps.
3. Mask margin is >5%. GPON transmitter eye mask definitions:

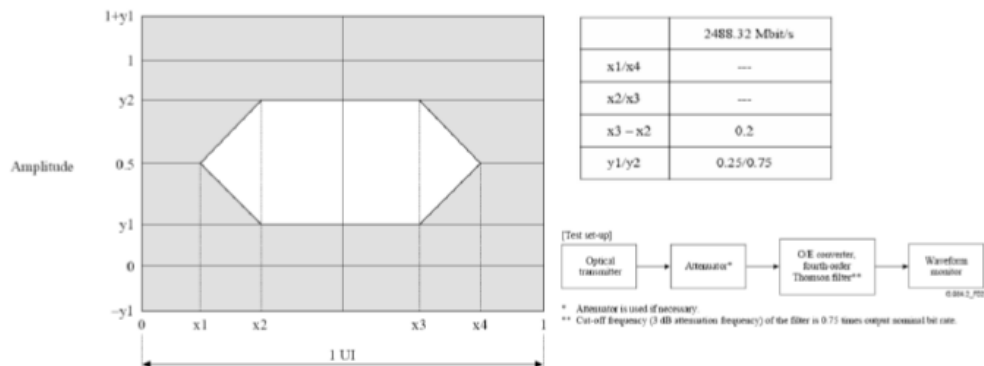

4. Transmit on 20KM SMF.
5. $ER \geq 10\text{dB}$, PRBS 2^{23} , @1.244Gbps, and $BER \leq 1 \times 10^{-4}$.

Pin Descriptions

Pin	Symbol	Name/Description	Notes
1	GPON_TD+	2.5G Transmit Data In.	1
2	GPON_TD-	Inverted 2.5G Transmit Data In.	1
3	GND	Module Ground.	
4	SDA	2-Wire Serial Interface Data.	2
5	SCL	2-Wire Serial Interface Clock.	3
6	GPON_RD-	Inverted Received 1G Data Out.	4
7	Reset & Rate Select	XGSPON Reset & Rate Select.	5
8	XGSPON SD	XGSPON SD Indicator.	6
9	Trig/Tx_Disable	Receiver RSSI Trigger Input/Transmitter Disable.	7
10	GPON_RD+	Received 1G Data Out.	4
11	GND	Module Ground.	
12	XGSPON_RD-	Inverted Received 10G Data Out.	8
13	XGSPON_RD+	Received 10G Data Out.	8
14	GPON SD	GPON SD Indicator.	
15	VccR	3.3V DC Power Input.	
16	VccT	3.3V DC Power Input.	
17	GPON RESET	GPON RESET.	
18	XGSPON_TD+	Differential 10G Transmit Data In.	1
19	XGSPON_TD-	Inverted Differential 10G Transmit Data In.	1
20	GND	Module Ground.	

Notes:

1. AC coupled. CML input.
2. The data line of the 2-wire serial interface.
3. The clock line of the 2-wire serial interface.
4. DC coupled. LVPECL output. This contact shall be pulled down with LVPECL output in the host.
5. High = Reset. Middle = 2.5G. Low = 10G. High voltage is greater than 1.9V. Intermediate voltage is 1.2V~1.6V. Low voltage is lower than 0.9V.
6. Low = Lost Signal.

7. The mode can be switched. A2 RSSI/TXDIS Selection:

Address	Bit	Name	Description
A2 BYTE118	7	RSSI Select	Writing "0" for XGS-PON RSSI Monitor; Writing "1" for GPON RSSI Monitor. Default power up value is "0".
	6	RSSI/ TXDIS Select	When set "0", PIN9 input as TXDIS input; When set "1", PIN9 as RSSI input. Default power up value is "0".
	5	XGSPON TXDIS Selection	When set "0", PIN9 as the XGS-PON TXDIS input. Default power-up value: "0". [4]
	4	GPON TXDIS Selection	When set "0", PIN9 as the GPON TXDIS input. Default power-up value: "0". [4]

8. DC coupled. CML output. While XGS SD is low level, the squelch function makes XGS LA output muting.

Electrical Pin-Out Details

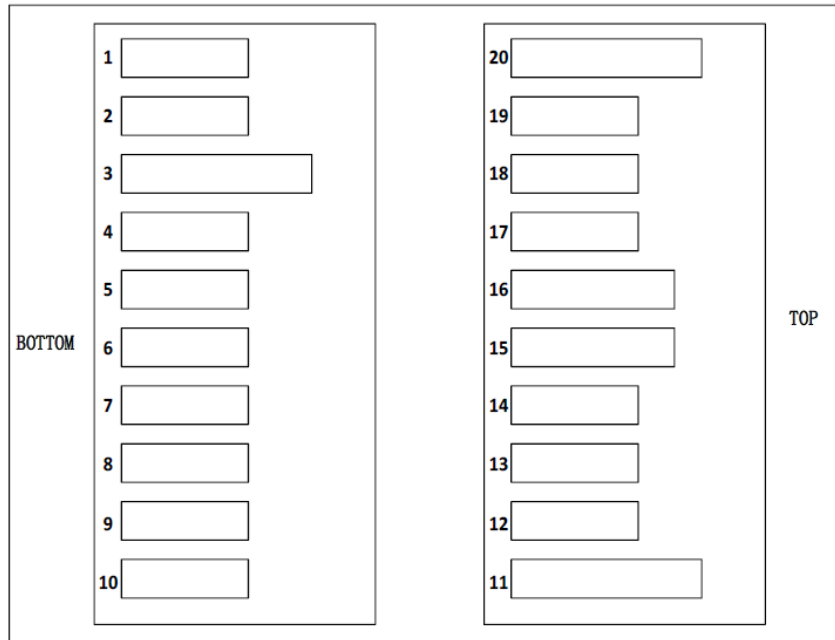

XGS Digital Diagnostic Monitoring Interface

Parameter	Range	Accuracy	Calibration	Page	Address	Notes
Temperature	0°C to 70°C	±3°C	Internal	A2	Byte 96~97, Byte96 is MSB	1
Voltage	2.97V to 3.63V	±5%	Internal	A2	Byte 98~99, Byte98 is MSB	2
Bias Current - XGS	0mA to 262mA	±10%	Internal	A2	Byte 100~101, Byte100 is MSB	3
Tx Power - XGS	8dBm to 11dBm	±2dB	Internal	A2	Byte 102~103, Byte102 is MSB	4
XGSPON Rx Power Monitor	-34dBm to -11dBm	±3dB	Internal	A2	Byte 104~105, Byte104 is MSB	5

Notes:

1. LSB: 1/256C.
2. LSB: 0.1mV.
3. LSB: 4uA.
4. LSB: 0.4uW.
5. LSB: 0.1uW.

GPON Digital Diagnostic Monitoring Interface

Parameter	Range	Accuracy	Calibration	Page	Address	Notes
Temperature	-40°C to 85°C	±3°C	Internal	B2	Byte 96~97, Byte96 is MSB	1
Voltage	2.97V to 3.63V	±5%	Internal	B2	Byte 98~99, Byte98 is MSB	2
Bias Current - GPON	0mA to 262mA	±10%	Internal	B2	Byte 100~101, Byte100 is MSB	3
Tx Power - GPON	6dBm to 10dBm	±2dB	Internal	B2	Byte 102~103, Byte102 is MSB	4
GPON Rx Power Monitor	-35dBm to -15dBm	±3dB	Internal	B2	Byte 104~105, Byte104 is MSB	5

Notes:

1. LSB: 1/256C.
2. LSB: 0.1mV.
3. LSB: 4uA.
4. LSB: 0.4uW.
5. LSB: 0.1uW.

EEPROM

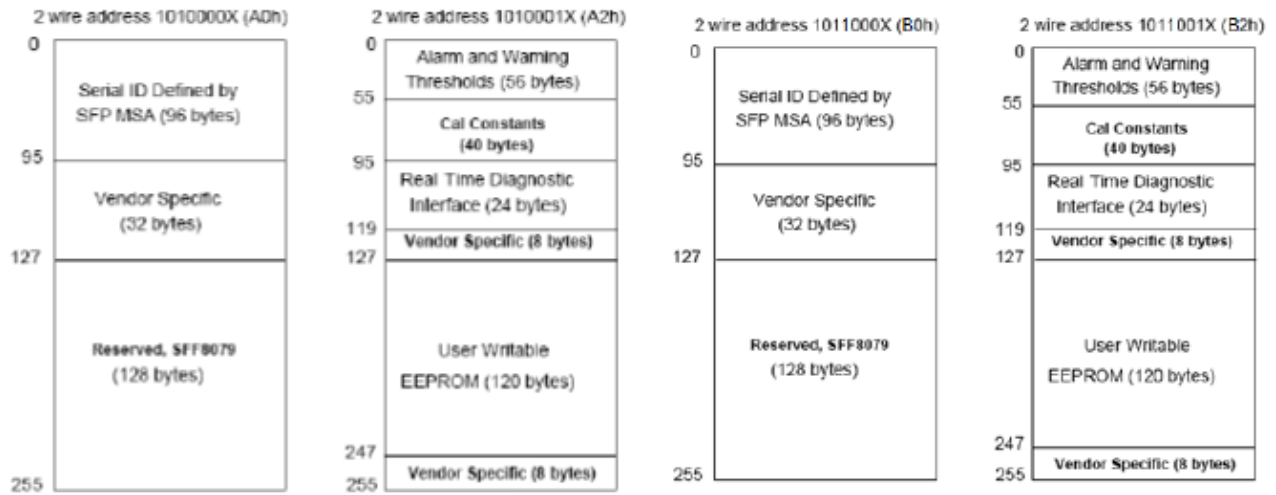

Notes:

- EEPROM memory map-specific data field descriptions.
- A0h(1010000X) and B0h(1011000X) are the Serial ID addresses for XGSPON/XGPON and GPON OLT, respectively.
- A2h(1010001X) and B2h(1011001X) are the Digital Diagnostic addresses for XGSPON/XGPON and GPON OLT, respectively.

Mechanical Specifications

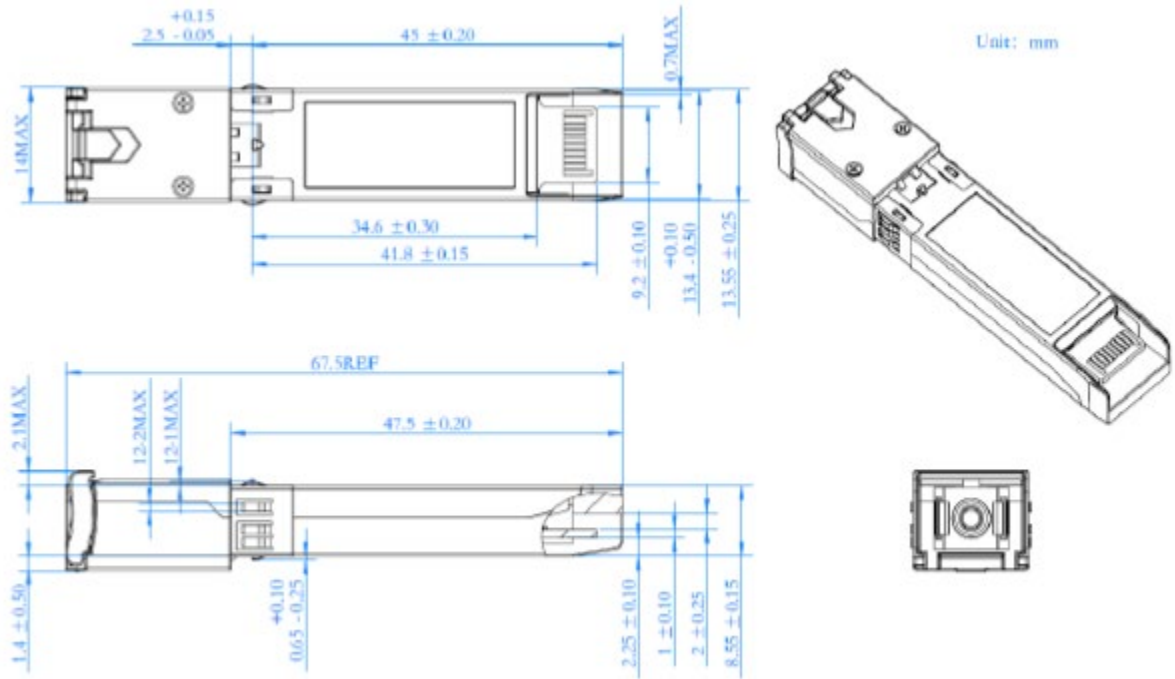

About ProLabs

Our extensive experience comes as standard. For over 20 years ProLabs has delivered optical connectivity solutions that give our customers freedom and choice through our ability to provide seamless interoperability. At the heart of our company is the ability to provide state-of-the-art optical transport and connectivity solutions that are compatible with more than 100 optical switching and transport platforms.

A Complete Portfolio of Network Solutions

ProLabs is focused on innovations in optical transport and connectivity. The combination of our knowledge of optics and networking equipment enables ProLabs to be your single source for optical transport and connectivity solutions from 100Mb to 1.6T while providing innovative solutions that increase network efficiency. We provide the optical connectivity expertise that is compatible with and enhances your switching and transport equipment.

The Trusted Partner

Customer service is our number one value. ProLabs has invested in people, labs and manufacturing capacity to ensure compatible products, and immediate answers to your questions. With Engineering and Manufacturing offices in the U.K. and U.S. augmented by field offices throughout the U.S., U.K. and Asia, ProLabs is able to be our customers best advocate 24 hours a day.



Contact Information

ProLabs US

Email: sales@prolabs.com

Telephone: 952-852-0252

ProLabs UK

Email: salessupport@prolabs.com

Telephone: +44 1285 719 600