

1442543F3-AO

ADTRAN® 1442543F3 Compatible TAA Combo PON OLT SFP+ Transceiver (SMF, 1577nmTx/1270nmRx and 1490nmTx/1310nmRx, D, SC, DOM, -40 to 85C)

Features

- 2x10 SFP+ Electrical Interface
- Hot-Pluggable
- SC Receptacle Optical Connector
- SFP+ Package
- 4 Lambda
- 3.3V DC Power Supply
- RoHS Compliant and Lead-Free
- Operating Temperature: -40 to 85 Celsius



Applications

- XGS-PON and GPON Combo OLT

Product Description

This ADTRAN® Combo PON OLT class D SFP+ transceiver provides 9.95Gbs/9.95Gbs and 2.48Gbs/1.24Gbs throughput up to 20km over single-mode fiber (SMF) using a wavelength of 1577nmTx/1270nmRx and 1490nmTx/1310nmRx via an SC connector. It can operate at temperatures between -40 and 85C. This product is in compliance with Multi-Source Agreement (MSA) standards to provide seamless network integration. Additional product features include Digital Optical Monitoring (DOM) support which allows access to real-time operating parameters. This transceiver is Trade Agreements Act (TAA) compliant. We stand behind the quality of our products and proudly offer a limited lifetime warranty.

AddOn's transceivers are RoHS compliant and lead-free.

TAA refers to the Trade Agreements Act (19 U.S.C. & 2501-2581), which is intended to foster fair and open international trade. TAA requires that the U.S. Government may acquire only "U.S.-made or designated country end products."



Absolute Maximum Ratings

Parameter	Symbol	Min.	Typ.	Max.	Unit	Notes
Operating Case Temperature	Tc	-40		85	°C	
Storage Temperature	Tstg	-40		85	°C	
Relative Humidity – Storage	RHstg	5		95	%	
Relative Humidity – Operating	RHc	5		85	%	
Supply Voltage	Vcc	0		3.6	V	

Notes:

1. Exceeding the Absolute Maximum Ratings may cause irreversible damage to the device. The device is not intended to be operated under the condition of simultaneous Absolute Maximum Ratings, a condition which may cause irreversible damage to the device.

Control Function Logic Levels

Parameter	Symbol	Min.	Max.	Unit	Notes
Tx_Disable	Tx_Disable	0	Vcc ₃ +0.5	V	LVTTTL
Burst-Mode Signal Detect	Rx_SD	0	Vcc ₃ +0.5	V	LVTTTL
Rx_Reset	Rx_Reset	0	Vcc ₃ +0.5	V	Single-Ended LVTTTL Input
Digital Rx_RSSI_Trigger Input	TRI	0	Vcc ₃ +0.5	V	Single-Ended LVTTTL Input
I2C Serial Data	SDA	0	Vcc ₃ +0.5	V	Single-Ended LVTTTL I/O
I2C Serial Clock	SCL	0	Vcc ₃ +0.5	V	Single-Ended LVTTTL Input

Electrical Characteristics

Parameter	Symbol	Min.	Typ.	Max.	Unit	Notes
Power Supply Voltage	V _{CC}	3.135	3.3	3.465	V	
Power Supply Current	I _{CC}		750		mA	
Power Consumption	P _C			3.5	W	
Transmitter						
Tx Differential Input Impedance	Z _{IN}	90	100	110	Ω	
10Gbps Tx Differential Input Amplitude	V _{IN10}	200		800	mV	
2.5Gbps Tx Differential Input Amplitude	V _{IN1}	300		800	mV	
Tx_Disable = High (Transmitter Off/Disabled)	V _{TDH}	2.0		V _{CC3}	V	1
Tx_Disable = Low (Transmitter On/Enabled)	V _{TDL}	0		0.8	V	1
Receiver						
Rx Differential Output Impedance	Z _{OUT}	90	100	110	Ω	
10Gbps Rx_Data Differential Output Voltage Amplitude	V _{OUT10}	300		850	mV	2
1.25Gbps Rx_Data Differential Output Voltage Amplitude	V _{OUT1}	600		1600	mV	3
Rx_SD = High (Receiver On)	V _{OH}	2.0		V _{CC3}	V	4
Rx_SD = Low (Receiver Off)	V _{OL}	0		0.8	V	4
Ratesel/Reset = High	V _{IH}	1.9		V _{CC3}	V	5
Ratesel/Reset = Middle	V _{IM}	1.2		1.6	V	5
Ratesel/Reset = Low	V _{IL}	0		0.9	V	5
Tri = High	V _{IH}	0.7*V _{CC3}		V _{CC3}	V	1
Tri = Low	V _{IL}	0		0.8	V	1

Notes:

1. LVTTTL (Control Input).
2. LVCML.
3. LVPECL.
4. LVTTTL (Monitor Output).
5. Tri-Level (Control Input).

9.95328Gbps Optical Characteristics

Parameter	Symbol	Min.	Typ.	Max.	Unit	Notes
Transmitter						
Laser Type		1577nm CW EML				
Downstream Signal Rate		9.95328			Gbps	
Average Launch Power	POUT ₁₀	5		8	dBm	
Optical Center Wavelength	λ_{10}	1575		1581	nm	
Spectral Width	$\Delta\lambda_{10}$			1.0	nm	
Side-Mode Suppression Ratio	SMSR ₁₀	30			dB	
Extinction Ratio	ER ₁₀	8.2			dB	
Output Eye Diagram	Compliant with ITU-T G.987.2 & ITU-T G.9807.1					
Receiver						
Receiver Type		1270nm APD/TIA Receiver				
Upstream Signal Rate		9.95328			Gbps	
Optical Center Wavelength	λ	1260		1280	nm	
XGS-PON Receiver Sensitivity	PIN			-29	dBm	1
XG-PON Receiver Sensitivity	PIN			-30.5	dBm	2
XGS-PON Receiver Optical Overload	PIN(SAT)	-8			dBm	
XG-PON Receiver Optical Overload	PIN(SAT)	-10			dBm	
Damaged Input Optical Power	PD			-5	dBm	
Rx_SD Assert	PA	-45		SEN-0.5	dBm	
Rx_SD De-Assert	PD	-45		SEN-0.5	dBm	
Rx_SD Hysteresis	PHY	0.5		7	dBm	

Notes:

1. BER @10⁻³, Test Condition, PRBS: 2³¹-1, ER=6dB.
2. BER @10⁻⁴, Test Condition, PRBS: 2²³-1, ER=8.2dB.

2.48832Gbps Optical Characteristics

Parameter	Symbol	Min.	Typ.	Max.	Unit	Notes
Transmitter						
Laser Type		1490nm CW DFB EML				
Downstream Signal Rate		2.48832			Gbps	
Average Launch Power	POUT ₁₀	3		7	dBm	
Optical Center Wavelength	λ_{10}	1480		1500	nm	
Spectral Width	$\Delta\lambda_{10}$			1.0	nm	
Side-Mode Suppression Ratio	SMSR ₁	30			dB	
Extinction Ratio	ER ₁	8.2			dB	
Optical Rise and Fall Time (20-80%)	Tr/Tf			200	ps	
Output Eye Diagram	Compliant with ITU-T G.984.2					
Receiver						
Receiver Type		1270nm APD/TIA Receiver				
Upstream Signal Rate		2.48832			Gbps	
Optical Center Wavelength	λ	1260		1280	nm	
XGS-PON Receiver Sensitivity	PIN			-29	dBm	1
XG-PON Receiver Sensitivity	PIN			-30.5	dBm	2
XGS-PON Receiver Optical Overload	PIN(SAT)	-8			dBm	
XG-PON Receiver Optical Overload	PIN(SAT)	-10			dBm	
Damaged Input Optical Power	PD			-5	dBm	
Rx_SD Assert	PA	-45		SEN-0.5	dBm	
Rx_SD De-Assert	PD	-45		SEN-0.5	dBm	
Rx_SD Hysteresis	PHY	0.5		7	dBm	

Notes:

1. BER @10⁻³, Test Condition, PRBS: 2³¹-1, ER=6dB.
2. BER @10⁻⁴, Test Condition, PRBS: 2²³-1, ER=8.2dB.

1.24416Gbps Optical Characteristics

Parameter	Symbol	Min.	Typ.	Max.	Unit	Notes
Receiver						
Receiver Type		1310nm Burst APD/TIA Receiver				
Upstream Signal Rate		1.24416			Gbps	
Optical Center Wavelength	λ	1290	1310	1330	nm	
Receiver Sensitivity	PIN			-30	dBm	1
Receiver Sensitivity	PIN			-32	dBm	2
Receiver Optical Overload	PIN(SAT)	-12			dBm	
Damaged Input Optical Power	PD			-5	dBm	
Rx_SD Assert	PA	-45		SEN-0.5	dBm	
Rx_SD De-Assert	PD	-45		SEN-0.5	dBm	
Rx_SD Hysteresis	PHY	0.5		7	dBm	

Notes:

1. BER @ 10^{-10} , PRBS: $2^{23}-1$, ER=10dB.
2. BER @ 10^{-4} , PRBS: $2^{23}-1$, ER=10dB.

Receiver Timing Diagram

Parameter	Symbol	Min.	Typ.	Max.	Unit	Notes
Guard Time (GPON)	Tg	25.6			ns	
Guard Time (XGS-PON)	Tg	51.2			ns	
Reset Pulse Width (GPON)	Tw	25.6			ns	
Reset Pulse Width (XGS-PON)	Tw	25.6			ns	1
Reset to Ranging ONU Optical Time	Trto	0			ns	
Reset Delay Time During Ranging	Trdr	0			ns	
Reset Time Overlapping Preamble	t_overlap	0			ns	
Setup Time of Rate Level For Following Burst	t_setup	5			ns	
Burst Signal Detect Assert (GPON)	T_SDA			25.6	ns	
Burst Signal Detect Assert (XGS-PON)	T_SDA		20	100	ns	
Burst Signal Detect De-Assert (GPON)	T_SDD		12.8	25.6	ns	
Burst Signal Detect De-Assert (XGS-PON)	T_SDD			100	ns	2
Burst-Mode Receiver Setting Time (GPON)	Tsettle			25.6	ns	
Burst-Mode Receiver Setting Time (XGS-PON)	Tsettle		100		ns	

Notes:

1. Reset pulse is required to be partially inside preamble.
2. Auto reset function is applied. Signal detect de-assert time is about 100ns forced by auto reset and will short to about 20ns with external reset pulse.

XGS-PON Normal Time Diagram

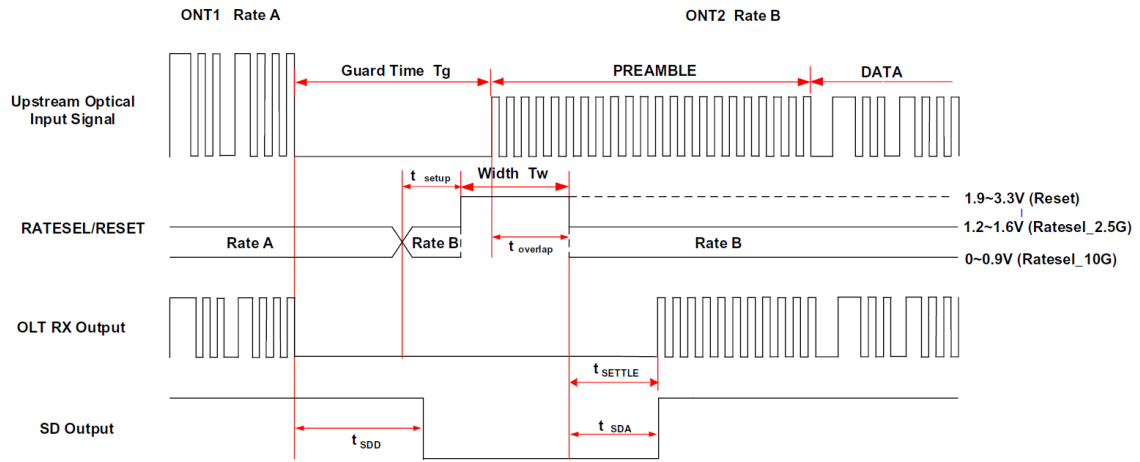

XGS-PON Ranging Time Diagram

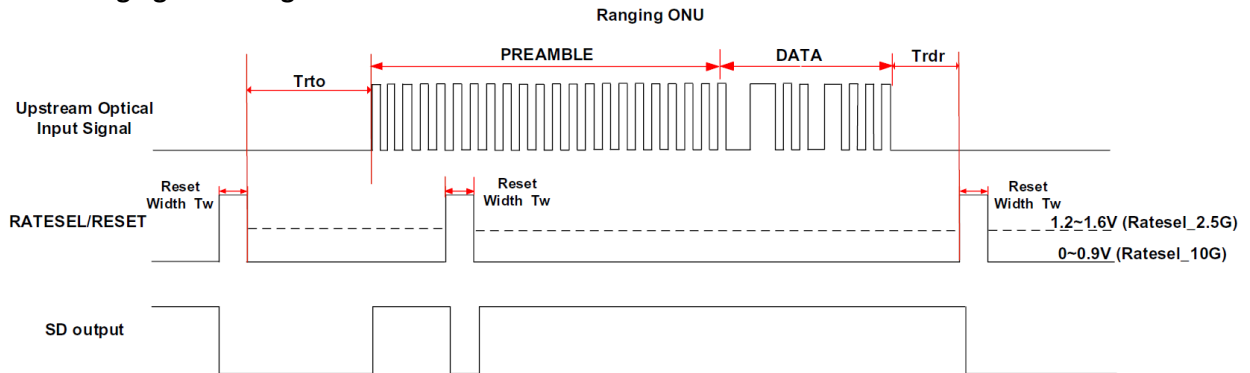

GPON Time Diagram

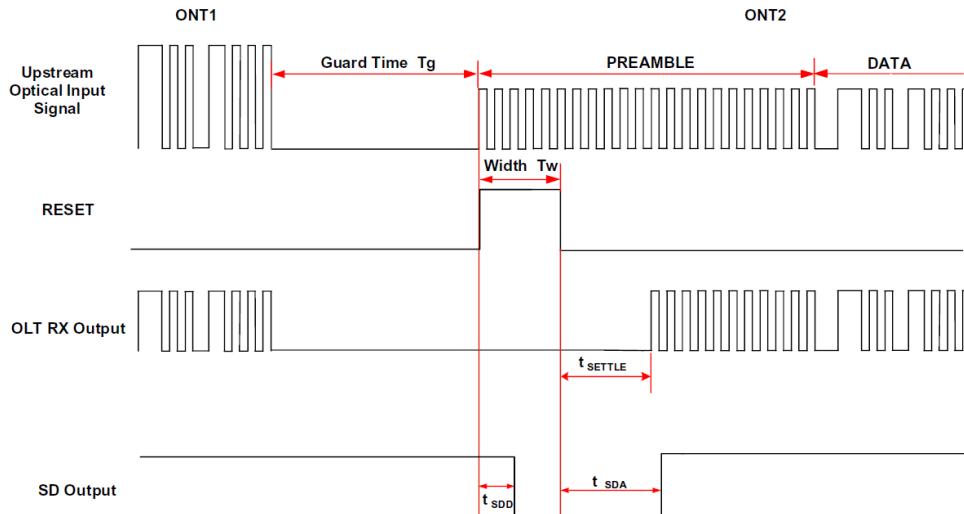

Digital RSSI Sample/Hold Timing

Parameter	Symbol	Min.	Typ.	Max.	Unit	Notes
Optical Input Signal Width	T_{ont}	525			ns	
RSSI Trigger Delay	T_{tri} (TRI Delay)	25		3000	ns	
RSSI Trigger Width	T_{i2c} (TRI Width)	500		$T_{ont}-T_{tri}$	ns	
I ² C Protect Time	T_p	500			μ s	
RSSI Monitor Range	P_{mon}	-29		-8	dBm	XGS-PON
		-31		-10	dBm	XGPON
		-32		-12	dBm	GPON
RSSI Precision	P_{rssi}	-3	+/-2	3	dB	

Notes:

- $T_{tri}+T_{i2c}<T_{ont}$.

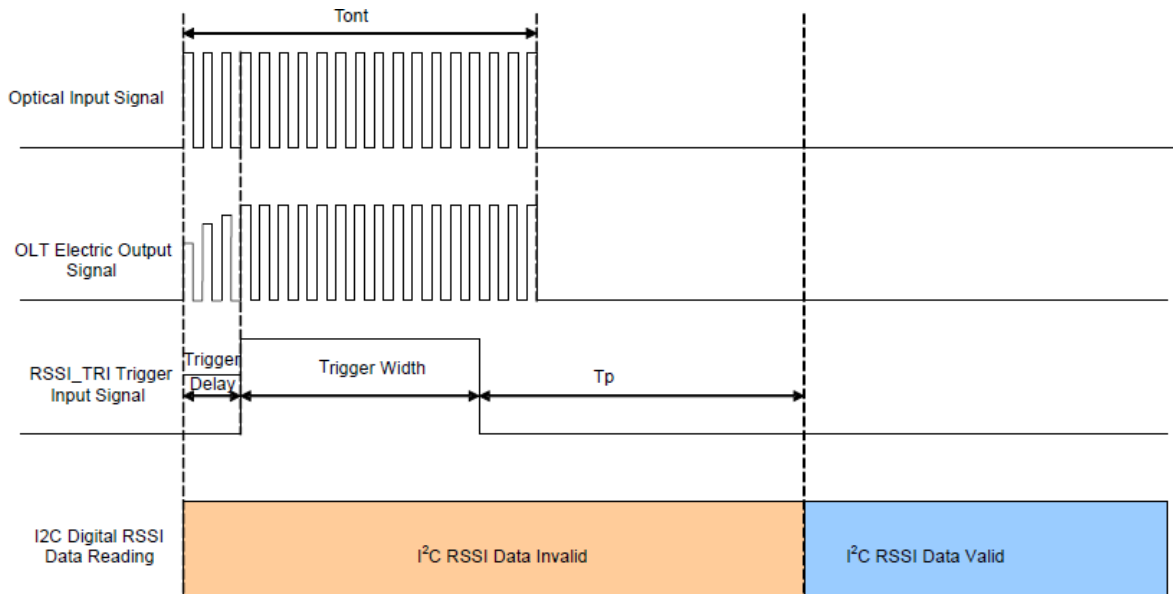

Pin Descriptions

Pin	Symbol	Name/Description	Notes
1	GPON_TD+	Transmit Non-Inverted 2.48832Gbps Data Input. AC coupled inside the module.	
2	GPON_TD-	Transmit Inverted 2.48832Gbps Data Input. AC coupled inside the module.	
3	GND	Module Ground.	
4	SDA	2-Wire Serial Interface Data. With the pull-up resistance 4.7kΩ to 10kΩ.	
5	SCL	2-Wire Serial Interface Clock. With the pull-up resistance 4.7kΩ to 10kΩ.	
6	GPON_RD-	Receive Burst-Mode Inverted 1.2488Gbps Data Output. DC coupled inside the module.	1
7	Ratesel/Reset	Three-level input combining “Rate Select” and “Reset” information. Set high level to reset TIA/LA. Middle level indicates 2.5G data rate. Low level indicates 10G data rate.	
8	XGS-PON_SD	Receiver Signal Detect Indicator for XGS-PON/XGPON Receiver. When low, indicates insufficient optical input power to the module. When high, indicates normal.	
9	Trig/Txdis	Two signals multiplex which is selected by the register. Receiver signal strength indication trigger for Digital RSSI. As Tx_Disable, when low level, the transceiver port works normally. When high level, both 10Gbps and 2.5Gbps are disabled.	
10	GPON_RD+	Receive Burst-Mode Non-Inverted 1.2488Gbps Data Output. DC coupled inside the module.	1
11	GND	Module Ground.	
12	XGS-PON_RD-	Receive Burst-Mode Inverted 9.953Gbps or 2.48832Gbps Data Output. DC coupled inside the module.	
13	XGS-PON_RD+	Receive Burst-Mode Non-Inverted 9.953Gbps or 2.48832Gbps Data Output. DC coupled inside the module.	
14	GPON_SD	Receiver Signal Detect Indicator for G-PON Receiver. When low, indicates insufficient optical input power to the module. When high, indicates normal.	
15	Vcc3_Rx	+3.3V Power Supply for Rx. Tolerance: 3.3V±5%.	
16	Vcc3_Tx	+3.3V Power Supply for Tx. Tolerance: 3.3V±5%.	
17	GPON_Reset	Burst-Mode Receiver Reset for GPON Receiver. When high, indicates that the receiver is off/being reset.	
18	XGS-PON_TD+	Transmit Non-Inverted 9.95328Gbps Data Input. AC coupled inside the module.	
19	XGS-PON_TD-	Transmit Inverted 9.95328Gbps Data Input. AC coupled inside the module.	
20	GND	Module Ground.	

Notes:

1. When GPON_RD+/- set as LVPECL and the module is without the pull-down resistances. The differential signal amplitude must be satisfied with the Electrical Characteristics.

Pin-Out Details

TOP VIEW OF BOARD

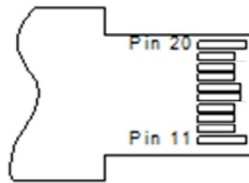

BOTTOM VIEW OF BOARD

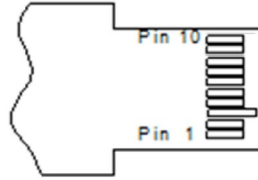

Electrical Interface

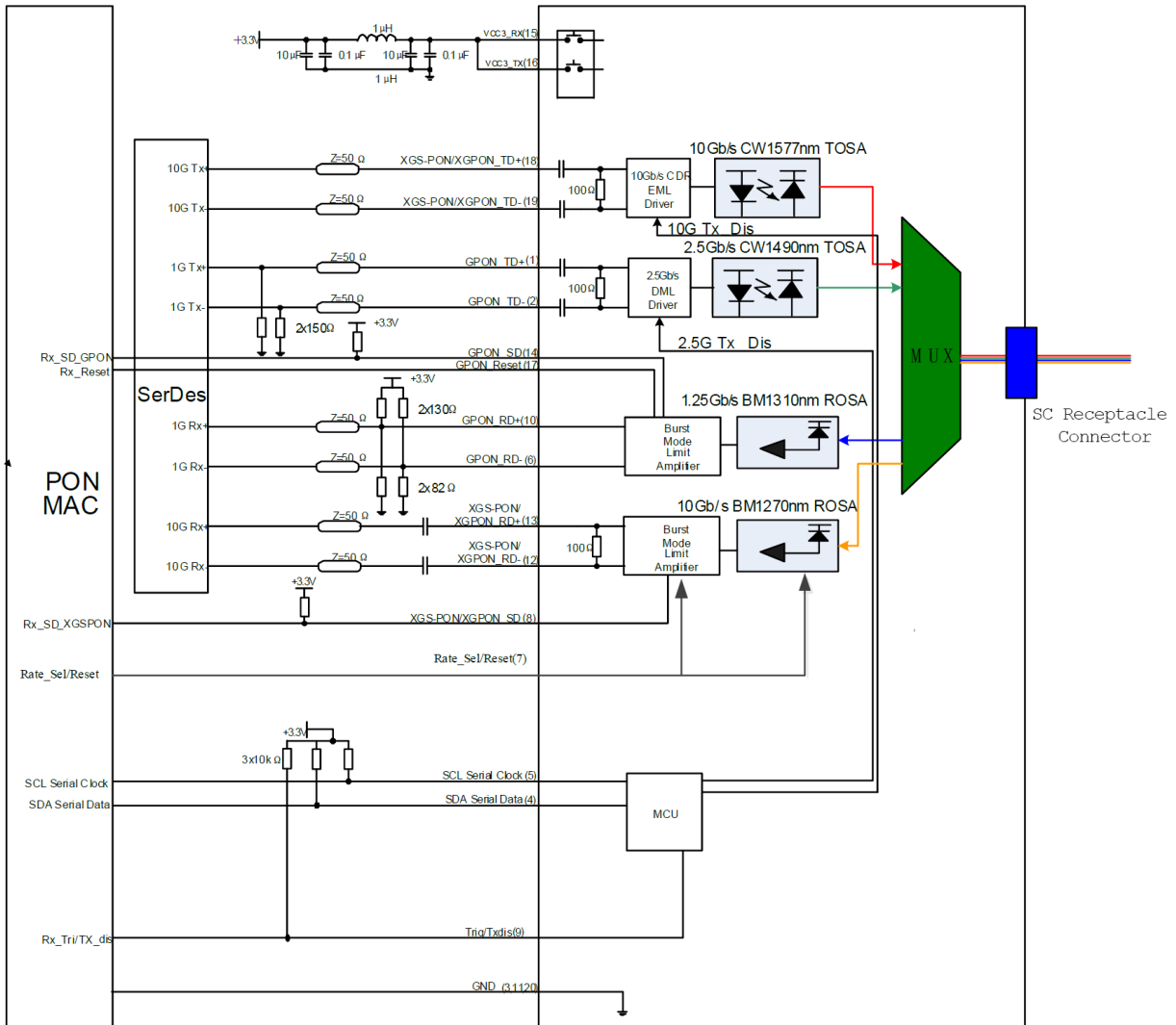

About AddOn Networks

In 1999, AddOn Networks entered the market with a single product. Our founders fulfilled a severe shortage for compatible, cost-effective optical transceivers that compete at the same performance levels as leading OEM manufacturers. Adhering to the idea of redefining service and product quality not previously had in the fiber optic networking industry, AddOn invested resources in solution design, production, fulfillment, and global support.

Combining one of the most extensive and stringent testing processes in the industry, an exceptional free tech support center, and a consistent roll-out of innovative technologies, AddOn has continually set industry standards of quality and reliability throughout its history.

Reliability is the cornerstone of any optical fiber network and is ingrained in AddOn's DNA. It has played a key role in nurturing the long-term relationships developed over the years with customers. AddOn remains committed to exceeding industry standards with certifications ranging from NEBS Level 3 to ISO 9001:2015 with every new development while maintaining the signature reliability of its products.



U.S. Headquarters

Email: sales@addonnetworks.com

Telephone: +1 877.292.1701

Fax: 949.266.9273

Europe Headquarters

Email: salesemea@addonnetworks.com

Telephone: +44 1285 842070