

QSFP-40GB-PSM4-BXD-40-N-C

Alcatel-Lucent Nokia® Compatible TAA 40GBase-BX QSFP+ Transceiver (SMF, 1330nmTx/1270nmRx, 40km, MPO, DOM)

Features:

- Compliant with IEEE802.3cp 10GBASE-BR40-D
- Compliant with QSFP+ MSA
- Compliant with SFF-8636
- Single-mode fiber
- 8-degree, angled MPO12 single-mode fiber connector
- Commercial Temperature 0 to 70 Celsius
- Hot Pluggable
- Excellent ESD Protection
- Metal with lower EMI
- RoHS compliant and lead-free



Applications:

- 40GBase-BX Ethernet
- Access, Metro and Enterprise

Product Description

This Alcatel-Lucent Nokia® compatible QSFP+ transceiver provides 40GBase-BX throughput up to 40km over single-mode fiber (SMF) using a wavelength of 1330nmTx/1270nmRx via an MPO connector. It can operate at temperatures between 0 and 70C. Our transceiver is built to meet or exceed OEM specifications and is guaranteed to be 100% compatible with Alcatel-Lucent Nokia®. It has been programmed, uniquely serialized, and tested for data-traffic and application to ensure that it will initialize and perform identically. All of our transceivers comply with Multi-Source Agreement (MSA) standards to provide seamless network integration. Additional product features include Digital Optical Monitoring (DOM) support which allows access to real-time operating parameters. This transceiver is Trade Agreements Act (TAA) compliant. We stand behind the quality of our products and proudly offer a limited lifetime warranty.

ProLabs' transceivers are RoHS compliant and lead-free.

TAA refers to the Trade Agreements Act (19 U.S.C. & 2501-2581), which is intended to foster fair and open international trade. TAA requires that the U.S. Government may acquire only "U.S.-made or designated country end products."



Absolute Maximum Ratings

Parameter	Symbol	Min.	Typ.	Max.	Unit	Note
Supply Voltage	Vcc	3.135		3.465	V	
Storage Temperature	Tstg	-40		85	°C	
Case Operating Temperature	Tc	0		70	°C	
Aggregated Data Rate Per Transceiver	DR		41.24		Gbps	1
Bit Rate (NRZ)	DR		10.3125		Gbps	2
Supported Link Length	Lmax1			40	km	3

Notes:

1. All channels.
2. Per optical transceiver block.
3. Single-mode fiber per G.652.
4. Distances up to 40km are conditional to the loss budget of the link. Not to exceed 18dB (including fiber loss, connector, TDP, and so forth), as per IEEE 802.3 CP specifications.

Electrical Characteristics

Parameter	Symbol	Min.	Typ.	Max.	Unit	Note
Supply Voltage	Vcc	3.15		3.465	V	
Symbol Rate Per Lane	BR		10.3125		Gbps	±100ppm
Input Voltage - Low	VIL	-0.3		0.8	V	
Input Voltage - High	VIH	2		3.	V	
Output Voltage - Low	VOL	-0.3		0.8	V	
Output Voltage - High	VOH	2		3.	V	
Differential Data Input Per Lane	VIN,pp	70		900	mV	
Differential Data Output Per Lane	VOUT,pp	100		900	mV	1

Notes

1. Internally AC coupled but requires an external 100Ω differential load termination.

Optical Characteristics

Parameter	Symbol	Min.	Typ.	Max.	Unit	Note
Transmitter						
Launch Optical Power	Pavg	-3		+3	dBm	Per Lane
	Pavg			-30	dBm	1
Lane Center Tx WL for Each of the Four Channels	λ	1320	1330	1340	nm	2
Extinction Ratio	ER	5.5			dB	
OMA-TDP	OMA-TDP	-1			dBm	
Transmitter Dispersion Penalty	TDP			2.6	dB	
Side-Mode Suppression Ratio	SMSR	30			dB	
Optical Return Loss Tolerance	ORLT			21	dB	
Transmitter Reflectance				-12	dB	
Eye Mask Margin		10			%	
Eye Mask: (X1, X2, X3, Y1, Y2, Y3)	Mask	(0.25, 0.4, 0.45, 0.25, 0.28, 0.4)				3
Receiver						
Lane Center Rx WL for Each of the Four Channels	λ	1260	1270	1280	nm	2
Unstressed Receiver Sensitivity (OMA)	RX-OMA	+2.5		-19	dBm	Per Lane
Stressed Receiver Sensitivity (OMA)	RX-Stress OMA			16.8	dBm	Per Lane
Average Receiver Power Per Lane	RXsense	-21.2		-7	dBm	
Damage Threshold	THd	-3			dBm	4
Reflectance				-26	dB	Per Lane
LOS De-Assert	LOSD			-22	dBm	
LOS Assert	LOSA	-35			dBm	5
LOS Hysteresis		0.5		4	dB	

Note:

1. Per lane in "off" mode.
2. Built-in optical BiDi demux for Tx/Rx for each channel.
3. Hit ratio of 1×10^{-12} , per IEEE.
4. Continuous exposure without damage.
5. Rx_LOS is asserted if any of the network optical lanes have LOS.

Pin Descriptions

Pin	Logic	Symbol	Name/Description	Note
1		GND	Module Ground.	1
2	CML-I	Tx2-	Transmitter Inverted Data Input.	
3	CML-I	Tx2+	Transmitter Non-Inverted Data Input.	
4		GND	Module Ground.	1
5	CML-I	Tx4-	Transmitter Inverted Data Input.	
6	CML-I	Tx4+	Transmitter Non-Inverted Data Input.	
7		GND	Module Ground.	1
8	LVTTTL-I	ModSelL	Module Select.	2
9	LVTTTL-I	ResetL	Module Reset.	2
10		VccRx	+3.3V Receiver Power Supply.	
11	LVC MOS-I	SCL	2-Wire Serial Interface Clock.	2
12	LVC MOS-I/O	SDA	2-Wire Serial Interface Data.	2
13		GND	Module Ground.	1
14	CML-O	Rx3+	Receiver Non-Inverted Data Output.	
15	CML-O	Rx3-	Receiver Inverted Data Output.	
16		GND	Module Ground.	1
17	CML-O	Rx1+	Receiver Non-Inverted Data Output.	
18	CML-O	Rx1-	Receiver Inverted Data Output.	
19		GND	Module Ground.	1
20		GND	Module Ground.	1
21	CML-O	Rx2-	Receiver Inverted Data Output.	
22	CML-O	Rx2+	Receiver Non-Inverted Data Output.	
23		GND	Module Ground.	1
24	CML-O	Rx4-	Receiver Inverted Data Output.	1
25	CML-O	Rx4+	Receiver Non-Inverted Data Output.	
26		GND	Module Ground.	1
27	LVTTTL-O	ModPrsL	Module Present. Internally pulled down to the GND.	
28	LVTTTL-O	IntL	Interrupt Output. Should be pulled up on the host board.	2
29		VccTx	+3.3V Transmitter Power Supply.	
30		Vcc1	+3.3V Power Supply.	
31	LVTTTL-I	LPMODE	Low-Power Mode.	2
32		GND	Module Ground.	1
33	CML-I	Tx3+	Transmitter Non-Inverted Data Input.	
34	CML-I	Tx3-	Transmitter Inverted Data Input.	
35		GND	Module Ground.	1
36	CML-I	Tx1+	Transmitter Non-Inverted Data Input.	
37	CML-I	Tx1-	Transmitter Inverted Data Input.	
38		GND	Module Ground.	1

Notes:

1. The module signal grounds are isolated from the module case.

- This is an open collector/drain output that, on the host board, requires a 4.7kΩ-10kΩ pull-up resistor to the Host_Vcc.

Electrical Pin-Out Details

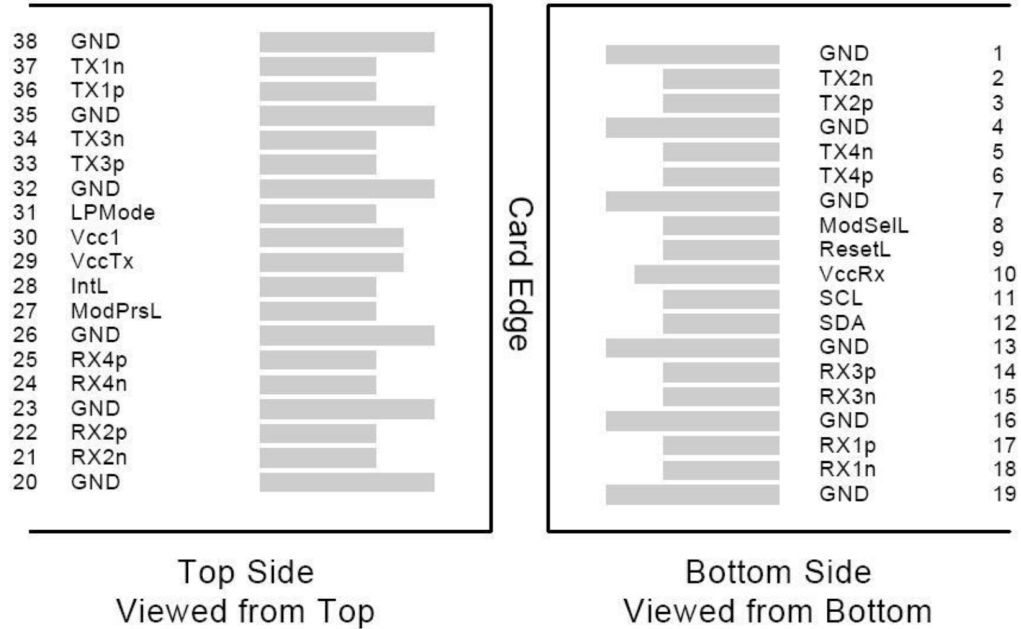

Power Supply Filtering

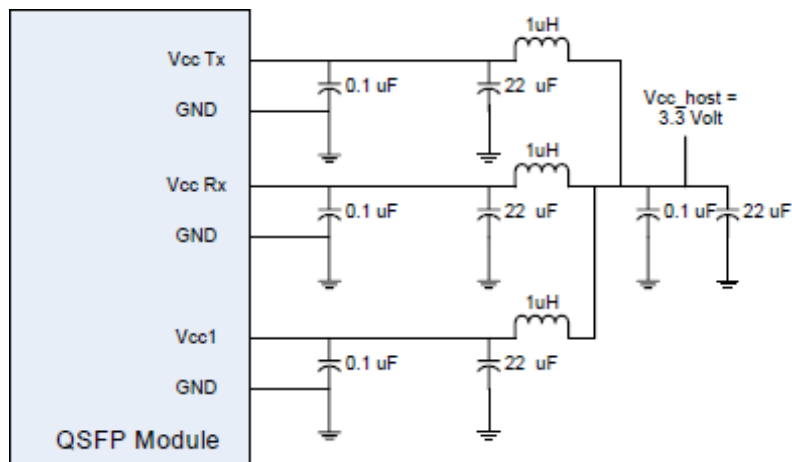

Transceiver Block Diagram

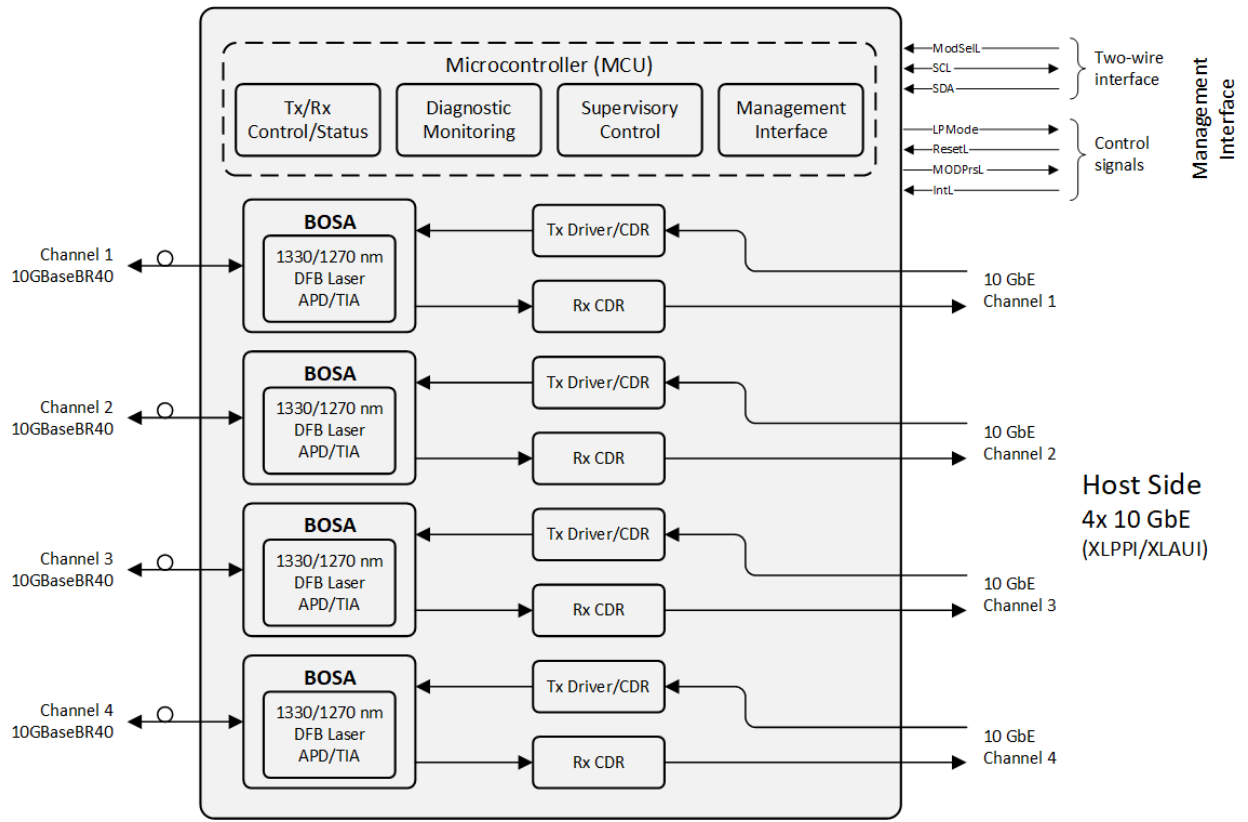

Mechanical Specifications

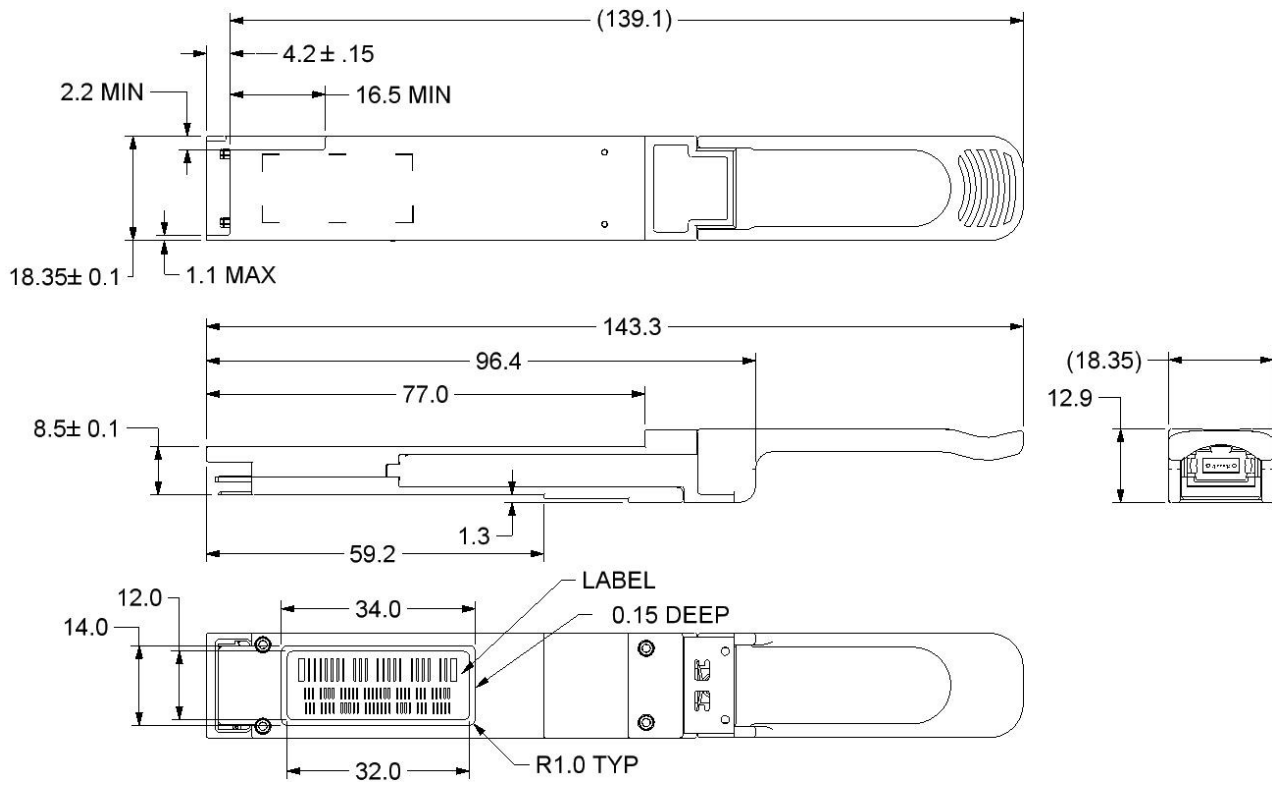

Dimensions are in mm.

MPO12 Connector – Front View

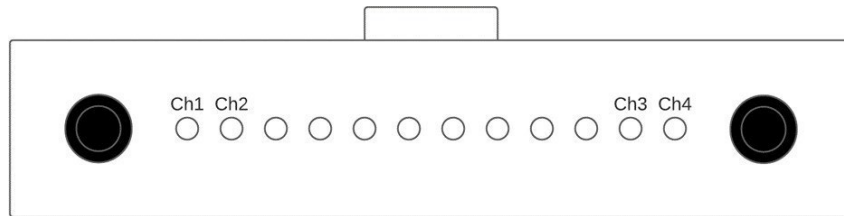

Fibers 1, 2, 11, and 12 are used.

About ProLabs

Our extensive experience comes as standard. For over 20 years ProLabs has delivered optical connectivity solutions that give our customers freedom and choice through our ability to provide seamless interoperability. At the heart of our company is the ability to provide state-of-the-art optical transport and connectivity solutions that are compatible with more than 100 optical switching and transport platforms.

A Complete Portfolio of Network Solutions

ProLabs is focused on innovations in optical transport and connectivity. The combination of our knowledge of optics and networking equipment enables ProLabs to be your single source for optical transport and connectivity solutions from 100Mb to 1.6T while providing innovative solutions that increase network efficiency. We provide the optical connectivity expertise that is compatible with and enhances your switching and transport equipment.

The Trusted Partner

Customer service is our number one value. ProLabs has invested in people, labs and manufacturing capacity to ensure compatible products, and immediate answers to your questions. With Engineering and Manufacturing offices in the U.K. and U.S. augmented by field offices throughout the U.S., U.K. and Asia, ProLabs is able to be our customers best advocate 24 hours a day.



Contact Information

ProLabs US

Email: sales@prolabs.com

Telephone: 952-852-0252

ProLabs UK

Email: salessupport@prolabs.com

Telephone: +44 1285 719 600