

## 1AB379640001-C

Alcatel-Lucent Nokia® Compatible TAA 4.25GBase-SX eSFP Transceiver (MMF, 850nm, 550m, LC)

### Features:

- INF-8074 and SFF-8472 Compliance
- Duplex LC Connector
- Multi-mode Fiber
- Commercial Temperature 0 to 70 Celsius
- Hot Pluggable
- Metal with Lower EMI
- Excellent ESD Protection
- RoHS Compliant and Lead Free



### Applications:

- Fibre Channel
- Access and Enterprise

### Product Description

This Alcatel-Lucent Nokia® 1AB379640001 compatible SFP transceiver provides 4.25GBase-SX throughput up to 550m over multi-mode fiber (MMF) using a wavelength of 850nm via an LC connector. It can operate at temperatures between 0 and 70C. It is guaranteed to be 100% compatible with the equivalent Alcatel-Lucent Nokia® transceiver. This easy to install, hot swappable transceiver has been programmed, uniquely serialized and data-traffic and application tested to ensure that it will initialize and perform identically. It is built to meet or exceed the specifications of Alcatel-Lucent Nokia®, as well as to comply with MSA (Multi-Source Agreement) standards to ensure seamless network integration. This transceiver is Trade Agreements Act (TAA) compliant. We stand behind the quality of our products and proudly offer a limited lifetime warranty.

ProLabs' transceivers are RoHS compliant and lead-free.

TAA refers to the Trade Agreements Act (19 U.S.C. & 2501-2581), which is intended to foster fair and open international trade. TAA requires that the U.S. Government may acquire only "U.S.-made or designated country end products."



## Absolute Maximum Ratings

Parameter	Symbol	Min.	Typ.	Max.	Unit
Maximum Supply Voltage	V <sub>CC</sub>	-0.5		3.6	V
Storage Temperature	T <sub>S</sub>	-40		+85	°C
Operating Case Temperature	T <sub>C</sub>	0		+70	°C
Operating Humidity	RH	0		95	%
Receiver Power	R <sub>MAX</sub>			-3	dBm
Data Rate			4.25		Gbps

## Electrical Characteristics (TOP=25°C, V<sub>CC</sub>=3.3Volts)

Parameter	Symbol	Min.	Typ.	Max.	Unit	Notes
Power Supply Voltage	V <sub>CC</sub>	3.15	3.30	3.45	V	
Power Supply Current	I <sub>CC</sub>			300	mA	
Transmitter						
Single ended data input swing	V <sub>in</sub>	400		1600	mVpp	1
Input differential impedance	Z <sub>in</sub>	85	100	115	Ω	2
Receiver						
Single ended data output swing	V <sub>out</sub>	400	800	1200	mVpp	1
Output differential impedance	Z <sub>in</sub>	85	100	115	Ω	

### Notes:

1. AC coupled.
2. R<sub>in</sub> > 100 kohms @ DC

## Optical Characteristics

Parameter	Symbol	Min.	Typ.	Max.	Unit	Notes
50µm Core Diameter MMF	L		150		m	
Data Rate			4.25		Gbps	
<b>Transmitter</b>						
Average Output Power	P <sub>out</sub>	-9		0	dBm	1
Optical Extinction Ratio	ER	5			dB	2
Optical Wavelength	Tλ	830	850	870	nm	
Spectral Width (RMS)	Δλ			0.85	nm	
P <sub>out</sub> @TX Disable Asserted	P <sub>out</sub>			-45	dBm	
Rise/Fall Time (20%~80%)	tr/tf			90	ns	
Total Jitter	TJ			0.07	UI	2
Output Optical Eye	Compliant with ANSI FC-PI specification					
<b>Receiver</b>						
Receiver Sensitivity	P <sub>min</sub>			-15	dBm	3
Receiver Overload	P <sub>max</sub>	-3			dBm	
Optical Center Wavelength	λ <sub>C</sub>	760		860	nm	
LOS De-Assert	LOSD			-16	dBm	
LOS Assert	LOSA	-30			dBm	
LOS Hysteresis		0.5			dB	

### Notes:

1. Output power is measured by coupling into a 50/125 um multi-mode fiber.
2. Filtered, measured with a PRBS 2<sup>7</sup>-1 test pattern @4250Mbps.
3. Minimum average optical power is measured at BER less than 1E-12, with 2<sup>7</sup>-1 PRBS

## Pin Descriptions

Pin	Symbol	Name/Descriptions	Ref.
1	VeeT	Transmitter Ground (Common with Receiver Ground).	1
2	TX Fault	Transmitter Fault. LVTTTL-O	2
3	TX Disable	Transmitter Disable. Laser output disabled on high or open. LVTTTL-I.	3
4	SDA	2-Wire Serial Interface Data Line (Same as MOD-DEF2 in INF-8074i). LVTTTL-I/O.	
5	SCL	2-Wire Serial Interface Data Line (Same as MOD-DEF2 in INF-8074i). LVTTTL-I.	
6	MOD_ABS	Module Absent, Connect to VeeT or VeeR in Module.	4
7	RS0	Rate Select 0. Not used	5
8	LOS	Loss of Signal indication. Logic 0 indicates normal operation. LVTTTL-O.	2
9	RS1	Rate Select 1. Not used	5
10	VeeR	Receiver Ground (Common with Transmitter Ground).	1
11	VeeR	Receiver Ground (Common with Transmitter Ground).	1
12	RD-	Receiver Inverted DATA out. AC Coupled. CML-O.	
13	RD+	Receiver Non-inverted DATA out. AC Coupled. CML-O.	
14	VeeR	Receiver Ground (Common with Transmitter Ground).	1
15	VccR	Receiver Power Supply.	
16	VccT	Transmitter Power Supply.	
17	VeeT	Transmitter Ground (Common with Receiver Ground).	1
18	TD+	Transmitter Non-Inverted DATA in. AC Coupled. CML-I.	
19	TD-	Transmitter Inverted DATA in. AC Coupled. CML-O.	
20	VeeT	Transmitter Ground (Common with Receiver Ground).	1

### Notes:

1. The module signal ground contacts, VeeR and VeeT, should be isolated from the module case.
2. This contact is an open collector/drain output and should be pulled up to the Vcc\_Host with resistor in the range 4.7K $\Omega$  to 10K $\Omega$ . Pull ups can be connected to one or several power supplies, however the host board design shall ensure that no module contract has voltage exceeding module VccT/R +0.5.V.
3. Tx\_Disable is an input contact with a 4.7K $\Omega$  to 10K $\Omega$  pull-up resistor to VccT inside module.
4. Mod\_ABS is connected to VeeT or VeeR in the SFP+ module. The host may pull the contract up to Vcc\_Host with a resistor in the range from 4.7K $\Omega$  to 10K $\Omega$ . Mod\_ABS is asserted "High" when the SFP+ module is physically absent from a host slot.
5. Internally pulled down per SFF-8431

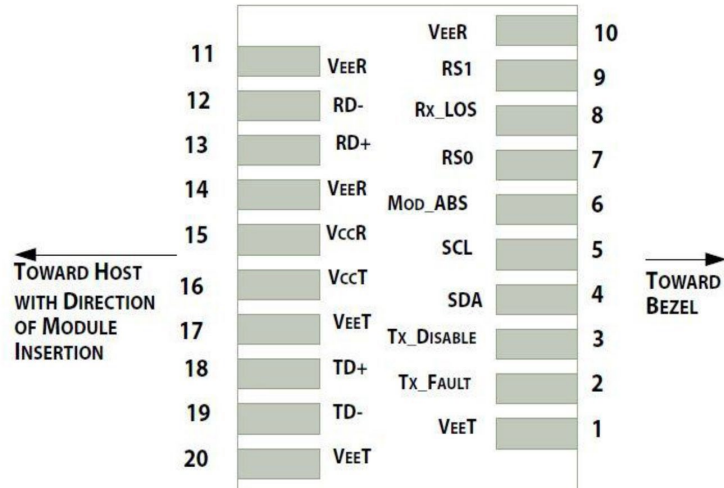

Pin-out of connector Block on Host board

### Recommended Circuit Schematic

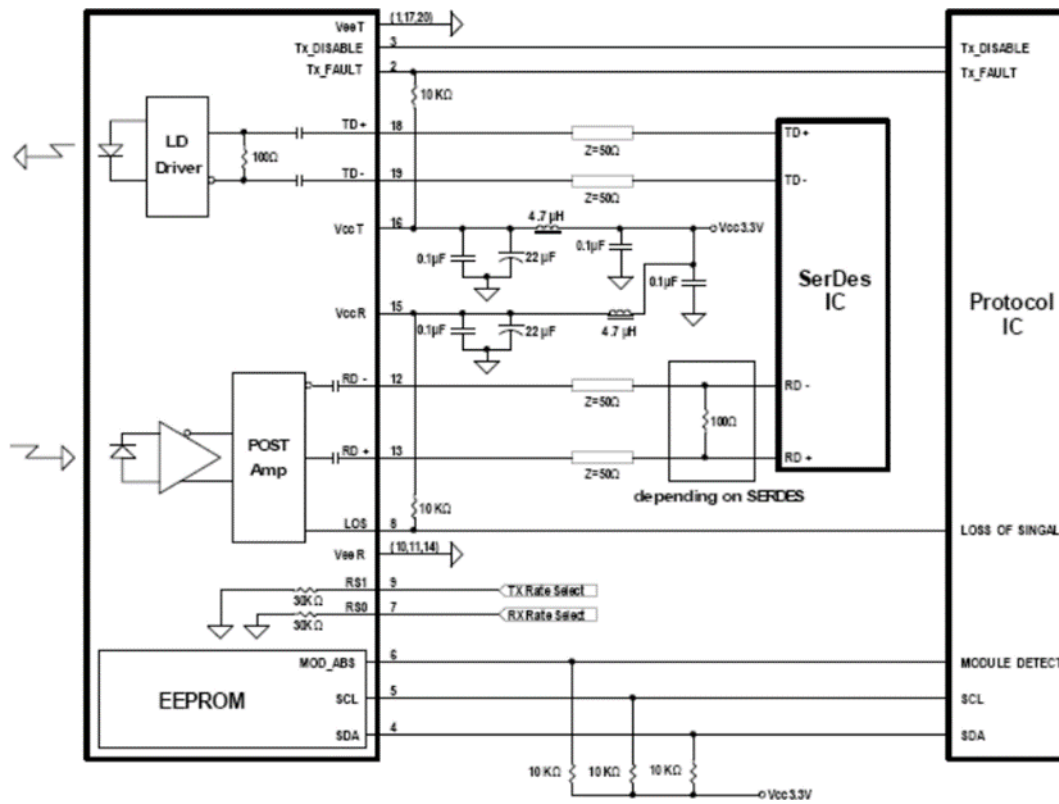

### Mechanical Specifications

Small Form Factor Pluggable (SFP) transceivers are compatible with the dimensions defined by the SFP Multi-Sourcing Agreement (MSA).

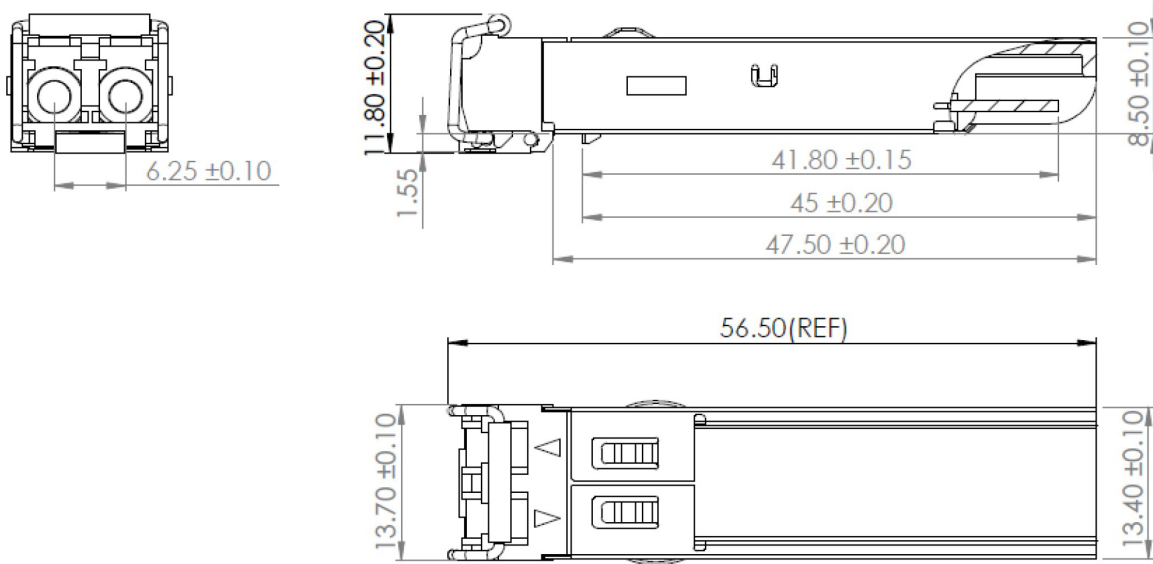

### EEPROM Information

EEPROM memory map specific data field description is as below:

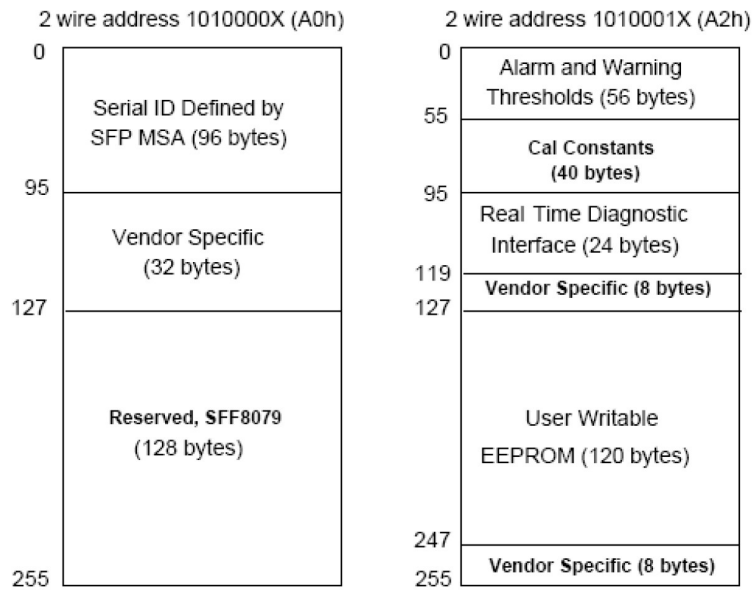

## About ProLabs

Our extensive experience comes as standard. For over 20 years ProLabs has delivered optical connectivity solutions that give our customers freedom and choice through our ability to provide seamless interoperability. At the heart of our company is the ability to provide state-of-the-art optical transport and connectivity solutions that are compatible with more than 100 optical switching and transport platforms.

## A Complete Portfolio of Network Solutions

ProLabs is focused on innovations in optical transport and connectivity. The combination of our knowledge of optics and networking equipment enables ProLabs to be your single source for optical transport and connectivity solutions from 100Mb to 1.6T while providing innovative solutions that increase network efficiency. We provide the optical connectivity expertise that is compatible with and enhances your switching and transport equipment.

## The Trusted Partner

Customer service is our number one value. ProLabs has invested in people, labs and manufacturing capacity to ensure compatible products, and immediate answers to your questions. With Engineering and Manufacturing offices in the U.K. and U.S. augmented by field offices throughout the U.S., U.K. and Asia, ProLabs is able to be our customers best advocate 24 hours a day.



## Contact Information

ProLabs US

Email: [sales@prolabs.com](mailto:sales@prolabs.com)

Telephone: 952-852-0252

ProLabs UK

Email: [salessupport@prolabs.com](mailto:salessupport@prolabs.com)

Telephone: +44 1285 719 600