

3HE16565AA-C

Alcatel-Lucent Nokia® 3HE16565AA Compatible TAA 400GBase-ZR+ QSFP-DD Transceiver (SMF, Coherent, LC, DOM, OpenZR+)

Features:

- Hot pluggable QSFP-DD footprint (Type 2A)
- Tunable C-band Transmitter
- Coherent Receivers
- Duplex LC connector
- Supports 400/300/200/100Gbps Payload
- Operating Temperature -5 to 80 Celsius
- O-FEC (15%) with 11.6dB Net Coding Gain
- 8x 26.5625GBd PAM4 Serial Electrical Interface
- 4x 25.78125GBd NRZ Serial Electrical Interface
- 2x 26.5625GBd PAM4 Serial Electrical Interface
- RoHS Compliant and Lead-Free

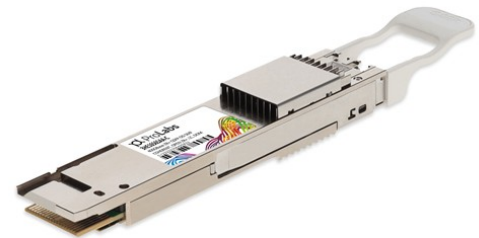

Applications:

- 400GBase Ethernet
- Access and Enterprise

Product Description

This Alcatel-Lucent Nokia® 3HE16565AA compatible QSFP-DD transceiver provides 400GBase-ZR Open ZR+ throughput over Single-mode fiber (SMF) using a coherent wavelength and using an LC connector. It is built to MSA standards and is uniquely serialized and data-traffic and application tested to ensure that they will integrate into your network seamlessly. Digital optical monitoring (DOM) support is also present to allow access to real-time operating parameters. This transceiver is Trade Agreements Act (TAA) compliant. We stand behind the quality of our products and proudly offer a limited lifetime warranty.

ProLabs' transceivers are RoHS compliant and lead-free.

TAA refers to the Trade Agreements Act (19 U.S.C. & 2501-2581), which is intended to foster fair and open international trade. TAA requires that the U.S. Government may acquire only "U.S.-made or designated country end products.")



Absolute Maximum Ratings

Parameter	Symbol	Min.	Typ.	Max.	Unit	Notes
Power Supply Voltage	VCC	3.135	3.3	3.465	V	
Storage Temperature	Ts	-40		85	°C	
Case Operating Temperature	Top	-5		80	°C	
Relative Humidity (non-condensing)	RH			85	%	
Optical Receiver Overload				1	dBm	1
Line Baud Rate			60.13855		GBd	2, 3, 4
Line Baud Rate			30.06927		GBd	5

Notes:

1. The optical input to the receiver should not exceed this value. Transmitters must never be directly connected to receivers before ensuring that proper optical attenuation is used
2. ZR400-OFEC-16QAM
3. ZR300-OFEC-8QAM
4. ZR200-OFEC-QPSK
5. ZR100-OFEC-QPSK

Electrical Characteristics

Parameter	Symbol	Min.	Typ.	Max.	Unit	Notes
Power Supply Voltage	Vcc	3.135	3.3	3.465	V	
Power Supply Current	Icc			6	A	
Power Consumption	PD		18.4	21.3	W	
Power Consumption	PD			1.5	W	1

Notes:

1. Low power mode

Optical Characteristics

Parameter	Symbol	Minimum	Typical	Maximum	Unit	Notes
Transmitter						
Average Output Power	P _o	-10	-8.5	-6	dBm	1, 2
Laser Linewidth				300	kHz	
Transmitter VOA Dynamic Range		10			dB	3
Output Power Stability		-1		1	dB	
In-Band OSNR		40			dB/0.1nm	
Out-of-Band OSNR		35			dB/0.1nm	
Frequency Range		191.275		196.125	THz	4
Centre Frequency		$\nu_T - 1.5$	ν_T	$\nu_T + 1.5$	GHz	5
Channel Spacing		6.25			GHz	
Centre Wavelength Range	$T\lambda$	1528.58		1567.34	nm	
Centre Wavelength	$T\lambda$	$\lambda_T - 15$	λ_T	$\lambda_T + 15$	pm	
Receiver						
Receiver Operating Wavelength	$R\lambda$	1528.58		1567.34	nm	
Receiver Sensitivity	S			-23	dBm	6, 7
	S			-30	dBm	8
	S			-32	dBm	9
Receiver Overload	P _{OL}	1			dBm	10
Receiver Input Power Range		-12		1	dBm	11, 12
		-15		1	dBm	11, 13
		-17		1	dBm	11, 14
		-20		1	dBm	11, 15
Extended Receiver Input Power Range		-15		1	dBm	16
Acquisition Range		-3.6		3.6	GHz	17
Upstream Tx Linewidth				500	kHz	
OSNR Tolerance			21.7	22.7	dB	12
			18.3	19.3	dB	13
			14	15	dB	14
			10.5	11	dB	15
Crosstalk Tolerance				7	dB	18
Chromatic Dispersion Tolerance				26000	ps/nm	12, 19
				50000	ps/nm	13, 14, 19
				80000	ps/nm	15, 19

Notes:

1. Output power coupled into a 9/125 μm single mode fibre
2. The output power is settable in steps of 0.1 dB within the specified wavelength range
3. With Tx VOA attenuation set to minimum
4. Per ITU-T G.694.1 DWDM grid definition
5. Applies also to LO
6. Minimum input power needed to achieve post-FEC BER $\leq 10^{-15}$, ZR400-OFEC-16QAM, OSNR > 35dB
7. Minimum input power needed to achieve post-FEC BER $\leq 10^{-15}$, ZR300-OFEC-8QAM, OSNR > 35dB
8. Minimum input power needed to achieve post-FEC BER $\leq 10^{-15}$, ZR200-OFEC-QPSK, OSNR > 35dB
9. Minimum input power needed to achieve post-FEC BER $\leq 10^{-15}$, ZR100-OFEC-QPSK, OSNR > 35dB
10. The optical input to the receiver should not exceed this value. Transmitters must never be directly connected to receivers before ensuring that proper optical attenuation is used
11. An input power in this range guarantees optimum OSNR performance
12. ZR400-OFEC-16QAM
13. ZR300-OFEC-8QAM
14. ZR200-OFEC-QPSK
15. ZR100-OFEC-QPSK
16. With ≤ 1 dB OSNR tolerance degradation
17. Frequency offset between received carrier and LO
18. Ratio of accumulated crosstalk channels to signal power
19. Less than 0.5dB receiver sensitivity penalty compared to OSNR > 35dB

Pin Descriptions

Pin	Logic	Symbol	Name/Descriptions	Plug Sequence
1		GND	Ground	1B
2	CML-I	Tx2n	Transmitter Inverted Data Input	3B
3	CML-I	Tx2p	Transmitter Non-Inverted Data Input	3B
4		GND	Ground	1B
5	CML-I	Tx4n	Transmitter Inverted Data Input	3B
6	CML-I	Tx4p	Transmitter Non-Inverted Data Input	3B
7		GND	Ground	1B
8	LVTTTL-I	ModSelL	Module Select	3B
9	LVTTTL-I	ResetL	Module Reset	3B
10		VccRx	+3.3V Power Supply Receiver	2B
11	LVC MOS-I/O	SCL	2-wire serial interface clock	3B
12	LVC MOS-I/O	SDA	2-wire serial interface data	3B
13		GND	Ground	1B
14	CML-O	Rx3p	Receiver Non-Inverted Data Output	3B
15	CML-O	Rx3n	Receiver Inverted Data Output	3B
16	GND	Ground	1B	
17	CML-O	Rx1p	Receiver Non-Inverted Data Output	3B
18	CML-O	Rx1n	Receiver Inverted Data Output	3B
19		GND	Ground	1B
20		GND	Ground	1B
21	CML-O	Rx2n	Receiver Inverted Data Output	3B
22	CML-O	Rx2p	Receiver Non-Inverted Data Output	3B
23		GND	Ground	1B
24	CML-O	Rx4n	Receiver Inverted Data Output	3B
25	CML-O	Rx4p	Receiver Non-Inverted Data Output	3B
26		GND	Ground	1B
27	LVTTTL-O	ModPrsL	Module Present	3B
28	LVTTTL-O	IntL	Interrupt	3B
29		VccTx	+3.3V Power supply transmitter	2B
30		Vcc1	+3.3V Power supply	2B
31	LVTTTL-I	InitMode	Initialization mode; In legacy QSFP applications, the InitMode pad is called LPMODE	3B
32		GND	Ground	1B
33	CML-I	Tx3p	Transmitter Non-Inverted Data Input	3B
34	CML-I	Tx3n	Transmitter Inverted Data Input	3B
35		GND	Ground	1B
36	CML-I	Tx1p	Transmitter Non-Inverted Data Input	3B
37	CML-I	Tx1n	Transmitter Inverted Data Input	3B
38		GND	Ground	1B
39		GND	Ground	1A
40	CML-I	Tx6n	Transmitter Inverted Data Input	3A

41	CML-I	Tx6p	Transmitter Non-Inverted Data Input	3A
42		GND	Ground	1A
43	CML-I	Tx8n	Transmitter Inverted Data Input	3A
44	CML-I	Tx8p	Transmitter Non-Inverted Data Input	3A
45		GND	Ground	1A
46		Reserved	For future use	3A
47		VS1	Module Vendor Specific 1	3A
48		VccRx1	3.3V Power Supply	2A
49		VS2	Module Vendor Specific 2	3A
50		VS3	Module Vendor Specific 3	3A
51		GND	Ground	1A
52	CML-O	Rx7p	Receiver Non-Inverted Data Output	3A
53	CML-O	Rx7n	Receiver Inverted Data Output	3A
54		GND	Ground	1A
55	CML-O	Rx5p	Receiver Non-Inverted Data Output	3A
56	CML-O	Rx5n	Receiver Inverted Data Output	3A
57		GND	Ground	1A
58		GND	Ground	1A
59	CML-O	Rx6n	Receiver Inverted Data Output	3A
60	CML-O	Rx6p	Receiver Non-Inverted Data Output	3A
61		GND	Ground	1A
62	CML-O	Rx8n	Receiver Inverted Data Output	3A
63	CML-O	Rx8p	Receiver Non-Inverted Data Output	3A
67		GND	Ground	1A
68		NC	No Connect	3A
69		Reserved	For future use	3A
70		VccTx1	3.3V Power Supply	2A
71		Vcc2	3.3V Power Supply	2A
72		Reserved	For Future Use	3A
73		GND	Ground	1A
74	CML-I	Tx7p	Transmitter Non-Inverted Data Input	3A
75	CML-I	Tx7n	Transmitter Inverted Data Input	3A
76		GND	Ground	1A

Electrical Pad Layout

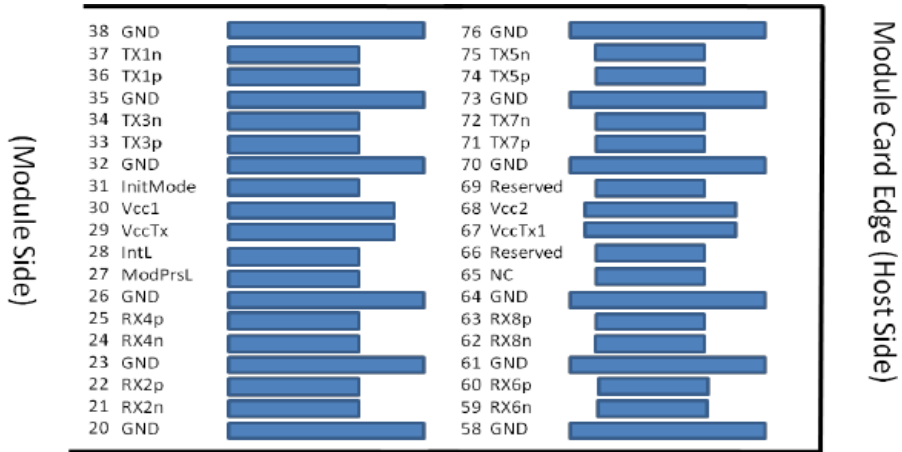

Top side viewed from top

Legacy QSFP28 Pads Additional QSFP-DD Pads

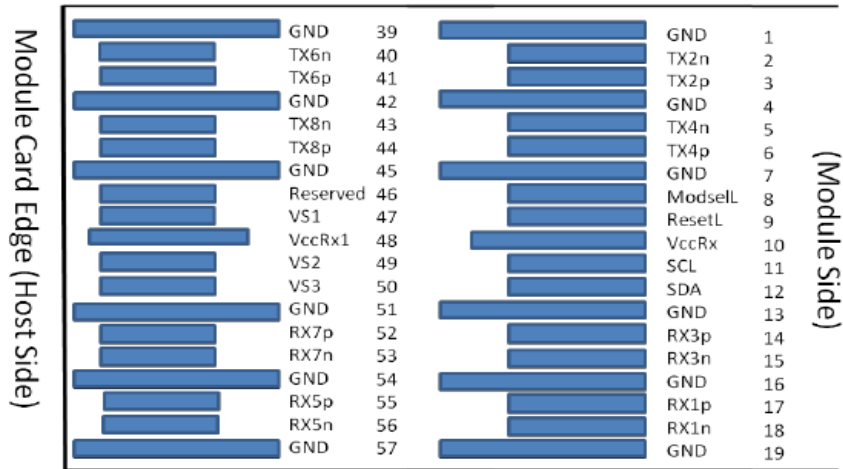

Bottom side viewed from bottom

Additional QSFP-DD Pads Legacy QSFP28 Pads

Recommended Power Supply Filter

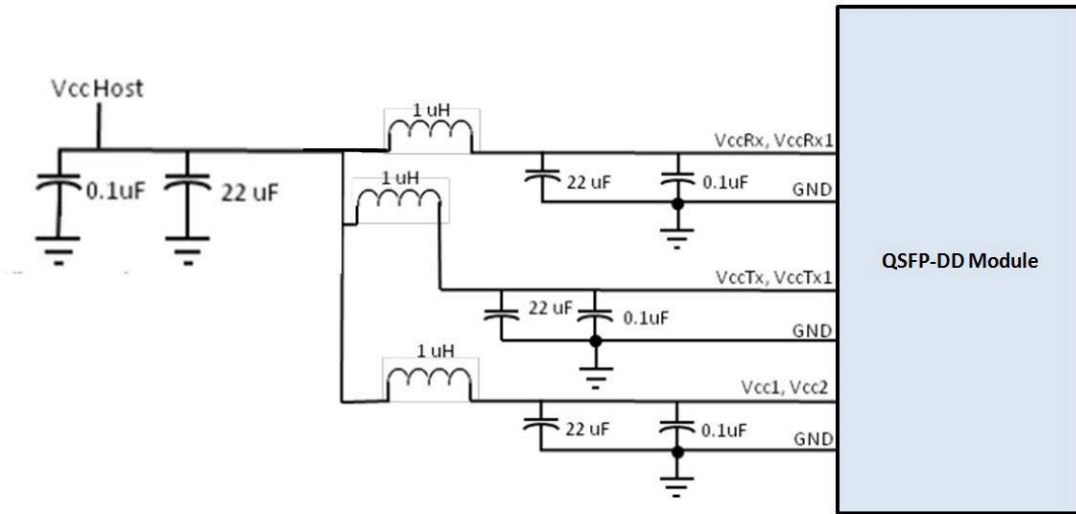

Mechanical Specifications

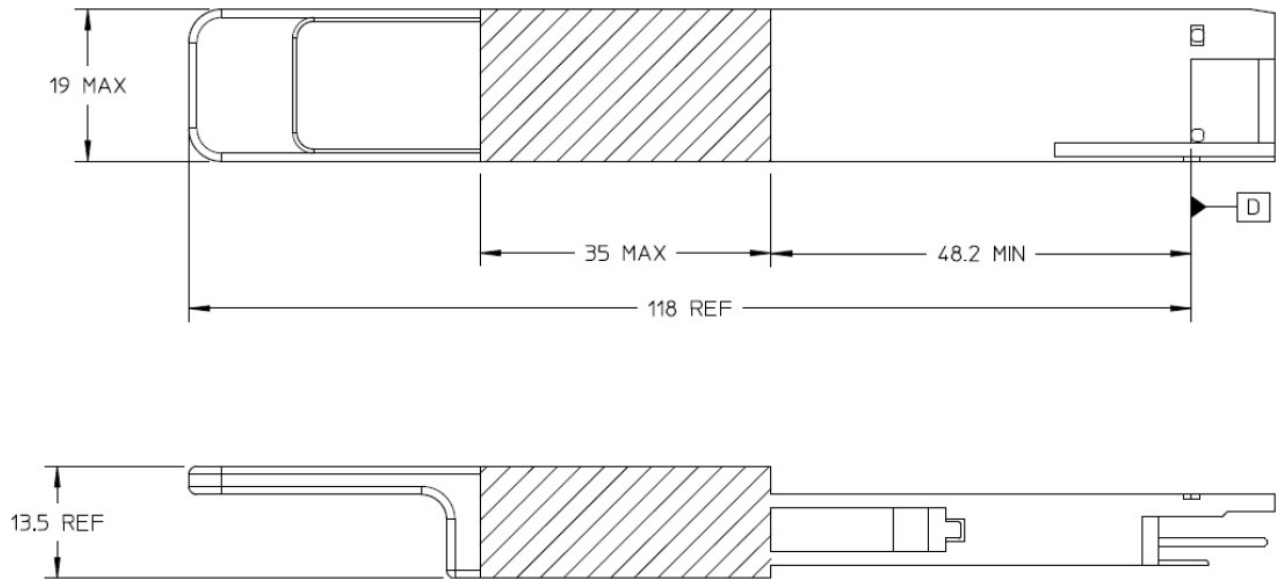

About ProLabs

Our extensive experience comes as standard. For over 20 years ProLabs has delivered optical connectivity solutions that give our customers freedom and choice through our ability to provide seamless interoperability. At the heart of our company is the ability to provide state-of-the-art optical transport and connectivity solutions that are compatible with more than 100 optical switching and transport platforms.

A Complete Portfolio of Network Solutions

ProLabs is focused on innovations in optical transport and connectivity. The combination of our knowledge of optics and networking equipment enables ProLabs to be your single source for optical transport and connectivity solutions from 100Mb to 1.6T while providing innovative solutions that increase network efficiency. We provide the optical connectivity expertise that is compatible with and enhances your switching and transport equipment.

The Trusted Partner

Customer service is our number one value. ProLabs has invested in people, labs and manufacturing capacity to ensure compatible products, and immediate answers to your questions. With Engineering and Manufacturing offices in the U.K. and U.S. augmented by field offices throughout the U.S., U.K. and Asia, ProLabs is able to be our customers best advocate 24 hours a day.



Contact Information

ProLabs US

Email: sales@prolabs.com

Telephone: 952-852-0252

ProLabs UK

Email: salessupport@prolabs.com

Telephone: +44 1285 719 600