

SFP-10/25GB-BXU23-20-I-N-C

Alcatel-Lucent Nokia® Compatible TAA 10/25GBase-BX SFP28 Transceiver (SMF, 1270nmTx/1330nmRx, 20km, LC, DOM, -40 to 85C)

Features:

- Hot-Pluggable SFP28 Form Factor
- Simplex LC Connector for Bi-Directional Transmission
- Supports 24.3Gbps to 26.5Gbps Bit Rates
- 1270nm 25Gbps DFB Laser Transmitter
- 1330nm 25Gbps PIN Receiver
- Internal CDR on both Transmitter and Receiver Channels
- Single 3.3V Power Supply
- Power Dissipation: 1.5W
- Digital Diagnostic Monitoring via the I2C Interface
- Operating Temperature: 0 to 70 Celsius
- RoHS Compliant and Lead-Free



Applications:

- 25GBase Ethernet

Product Description

This Alcatel-Lucent Nokia® compatible SFP28 transceiver provides 10/25GBase-BX throughput up to 20km over single-mode fiber (SMF) using a wavelength of 1270nmTx/1330nmRx via an LC connector. This bidirectional unit must be used with another transceiver or network appliance of complementing wavelengths. It can operate at temperatures between -40 and 85C. Our transceiver is built to meet or exceed OEM specifications and is guaranteed to be 100% compatible with Alcatel-Lucent Nokia®. It has been programmed, uniquely serialized, and tested for data-traffic and application to ensure that it will initialize and perform identically. All of our transceivers comply with Multi-Source Agreement (MSA) standards to provide seamless network integration. Additional product features include Digital Optical Monitoring (DOM) support which allows access to real-time operating parameters. We stand behind the quality of our products and proudly offer a limited lifetime warranty.

ProLabs' transceivers are RoHS compliant and lead-free.

TAA refers to the Trade Agreements Act (19 U.S.C. & 2501-2581), which is intended to foster fair and open international trade. TAA requires that the U.S. Government may acquire only "U.S.-made or designated country end products."



Absolute Maximum Ratings

Parameter	Symbol	Min.	Typ.	Max.	Unit	Notes
Maximum Supply Voltage	Vcc	0		3.6	V	
Storage Temperature	Tstg	-40		85	°C	
Operating Case Temperature	Tc	0		70	°C	
Relative Humidity	RH	5		85	%	
Data Rate	DR		25.78		Gbps	

Electrical Characteristics

Parameter	Symbol	Min.	Typ.	Max.	Unit	Notes
Power Supply Voltage	Vcc	3.13	3.3	3.47	V	
Power Supply Current	Icc			450	mA	
Transmitter						
Input Differential Impedance	RIN		100		Ω	
Data Input Swing Differential	VIN,pp	50		1000	mV	
Tx_Disable	Disable		2.0		Vcc	
	Enable		0		0.4	
Tx_Fault	Fault		2.4		Vcc	
	Normal		0		0.4	
Receiver						
Data Output Swing Differential	VOUT,pp	400		1100	mV	
LOS Fault		2.0		Vcc	V	
LOS Normal		0		0.8	V	

Optical Characteristics

Parameter	Symbol	Min.	Typ.	Max.	Unit	Notes
Transmitter						
Center Wavelength	λ_C	1260	1270	1280	nm	
Spectral Width (-20dB)	σ			1	nm	
Side-Mode Suppression Ratio	SMSR	30			dB	
Average Output Power	Pavg	-3		3	dBm	
Extinction Ratio	ER	3.5			dB	
Transmitter and Dispersion Penalty	TDP			2.7	dB	
Power Off Tx_Disable	Poff			-30	dBm	
Transmitter Reflection				-26	dB	
Optical Return Loss Tolerance				20	dB	
RIN _{20OMA}				-130	dB/Hz	
Transmitter Eye Mask		(0.31, 0.4, 0.45, 0.34, 0.38, 0.4)				
Receiver						
Center Wavelength	λ_C	1320	1330	1340	nm	
Sensitivity	SEN			-13.3	dBm	1
Overload		2			dBm	
LOS De-Assert	LOSD			-13.5	dBm	
LOS Assert	LOSA	-30			dBm	
LOS Hysteresis		0.5		5	dB	

Notes:

1. Measured with a PRBS 2³¹-1 test pattern @25.78Gbps and BER@5E⁻⁵.

Pin Descriptions

Pin	Symbol	Name/Description	Notes
1	VeeT	Module Transmitter Ground.	1
2	Tx_Fault	Module Transmitter Fault.	2
3	Tx_Disable	Transmitter Disable. Turns off transmitter laser output.	3
4	SDA	2-Wire Serial Interface Data.	4
5	SCL	2-Wire Serial Interface Clock.	4
6	MOD_ABS	Module Absent. Grounded within the module.	5
7	RS0	Receiver Rate Select. Not Used.	
8	Rx_LOS	Receiver Loss of Signal Indication. Active High.	2
9	RS1	Transmitter Rate Select. Not Used.	
10	VeeR	Module Receiver Ground.	1
11	VeeR	Module Receiver Ground.	1
12	RD-	Receiver Inverted Data Output.	
13	RD+	Receiver Non-Inverted Data Output.	
14	VeeR	Module Receiver Ground.	1
15	VccR	Module Receiver +3.3V Power Supply.	
16	VccT	Module Transmitter +3.3V Power Supply.	
17	VeeT	Module Transmitter Ground.	1
18	TD+	Transmitter Non-Inverted Data Input.	
19	TD-	Transmitter Inverted Data Input.	
20	VeeT	Module Transmitter Ground.	1

Notes:

1. The module signal ground pins, VeeR and VeeT, should be isolated from the module case.
2. This pin is an open collector/drain output pin that shall be pulled up with 4.7kΩ to 10kΩ to the Host_Vcc on the host board. Pull-ups can be connected to multiple power supplies; however, the host board design shall ensure that no module pin has a voltage exceeding the module VccT/VccR+0.5V.
3. This pin is an open collector/drain input pin that should be pulled up with 4.7kΩ to 10kΩ to the VccT in the module.
4. See SFF-8431 4.2 2-wire electrical specifications.
5. This pin shall be pulled up with 4.7kΩ to 10kΩ to the Host_Vcc on the host board.

Pin Assignments

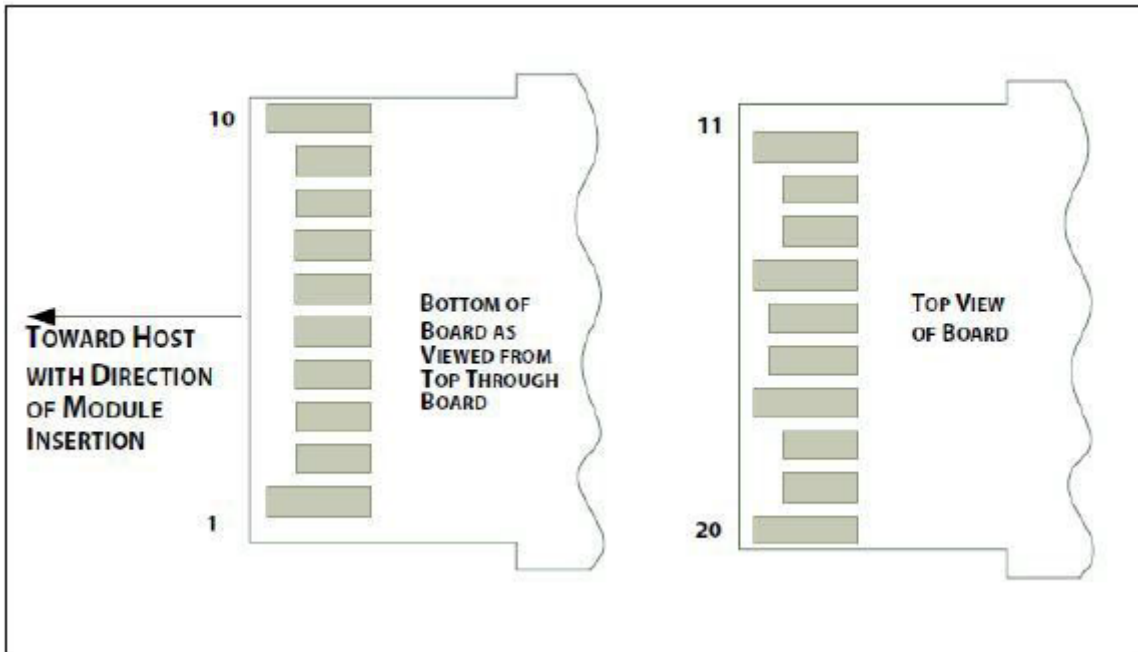
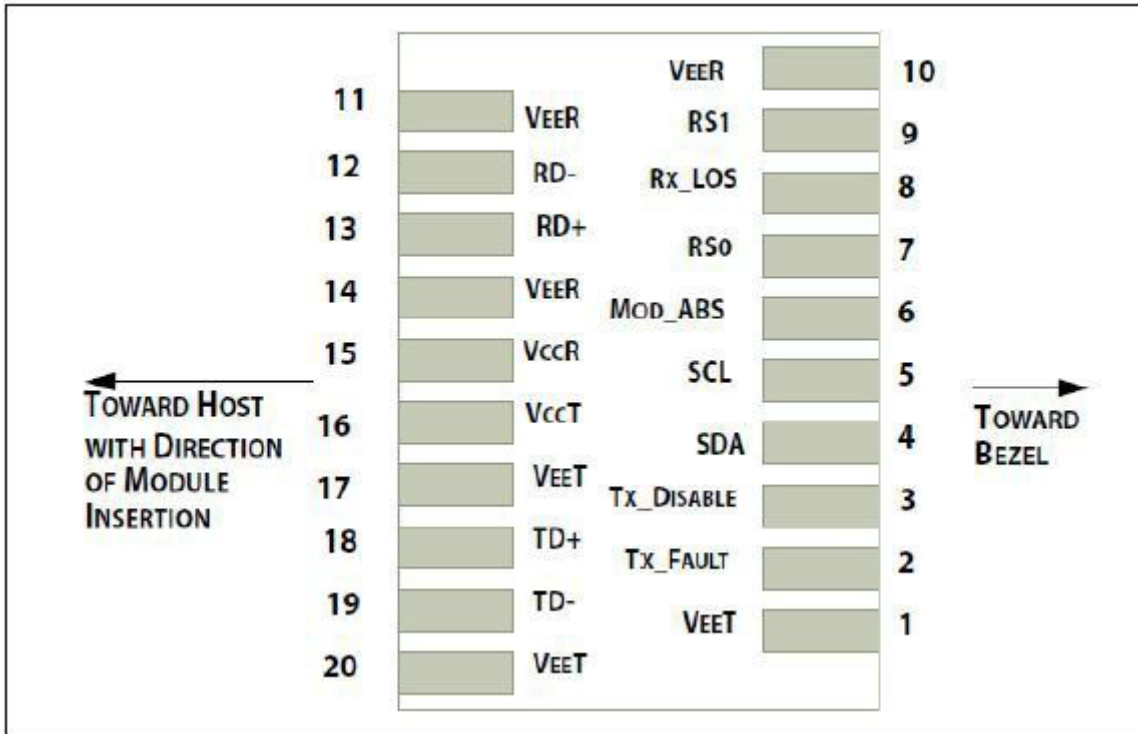

Recommended Interface Circuit

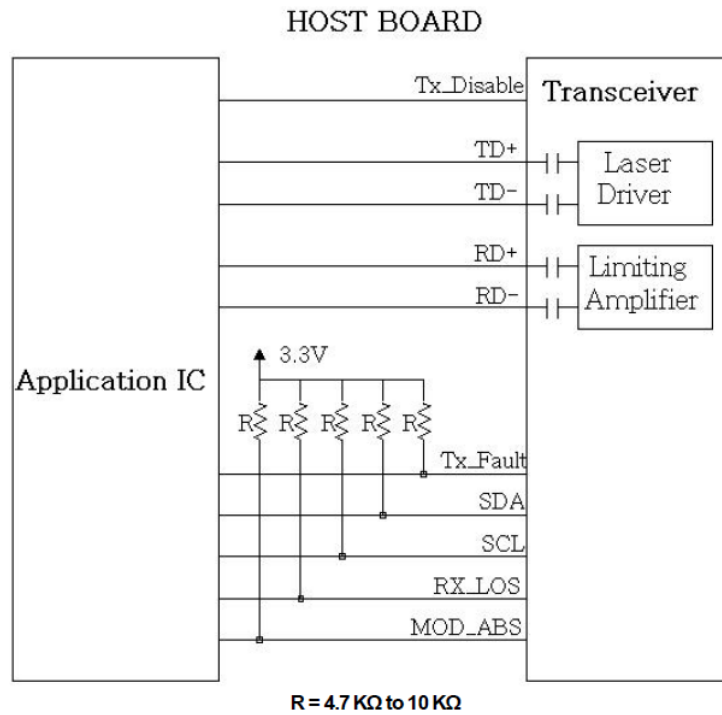

Mechanical Specifications

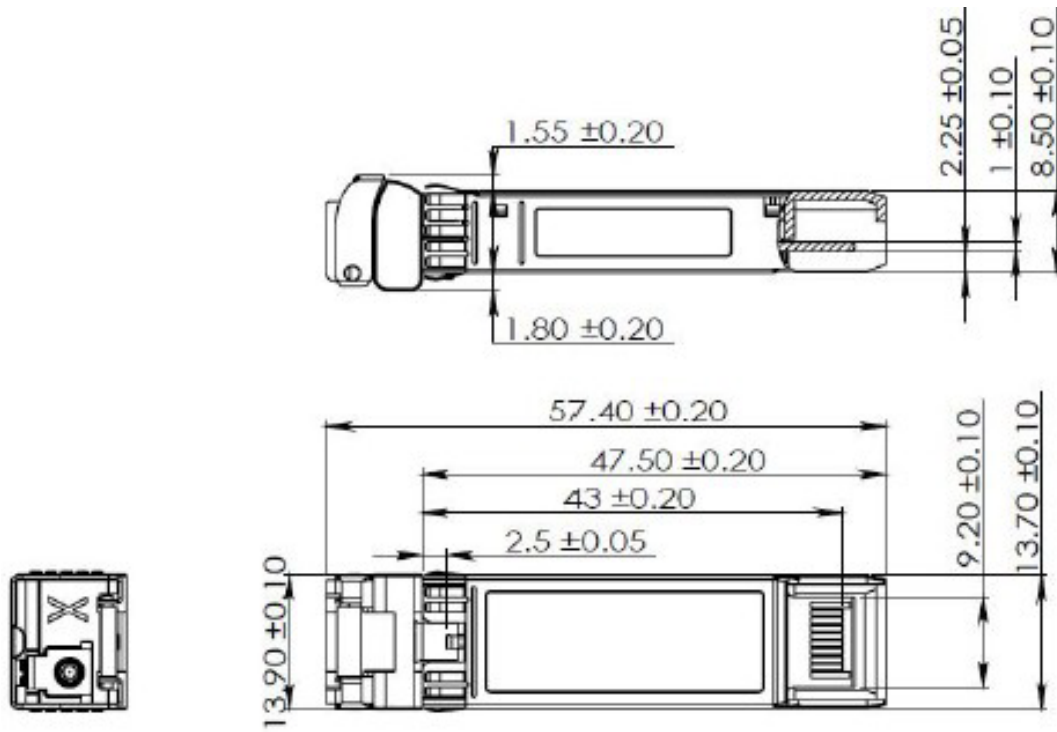

Unit:mm

About ProLabs

Our extensive experience comes as standard. For over 20 years ProLabs has delivered optical connectivity solutions that give our customers freedom and choice through our ability to provide seamless interoperability. At the heart of our company is the ability to provide state-of-the-art optical transport and connectivity solutions that are compatible with more than 100 optical switching and transport platforms.

A Complete Portfolio of Network Solutions

ProLabs is focused on innovations in optical transport and connectivity. The combination of our knowledge of optics and networking equipment enables ProLabs to be your single source for optical transport and connectivity solutions from 100Mb to 1.6T while providing innovative solutions that increase network efficiency. We provide the optical connectivity expertise that is compatible with and enhances your switching and transport equipment.

The Trusted Partner

Customer service is our number one value. ProLabs has invested in people, labs and manufacturing capacity to ensure compatible products, and immediate answers to your questions. With Engineering and Manufacturing offices in the U.K. and U.S. augmented by field offices throughout the U.S., U.K. and Asia, ProLabs is able to be our customers best advocate 24 hours a day.



Contact Information

ProLabs US

Email: sales@prolabs.com

Telephone: 952-852-0252

ProLabs UK

Email: salessupport@prolabs.com

Telephone: +44 1285 719 600