

SFPP-XGS-ONU-MAC-ASC-I-N-AO

Alcatel-Lucent Nokia® Compatible 9.95Gbs/9.95Gbs XGS PON ONU SFP+ Stick with MAC (SMF, 1270nmTx/1577nmRx, ASC, -40 to 85C)

Features

- Dual Wavelength
- 9.95328Gbps Burst Mode Tx Data Rate
- Bidirectional Operation
- ITU-T G.984.3/G.988/G.9807.1/G.987.3 Compliant
- ASC Optical Receptacle
- 9.95328Gbps CW Mode Rx Data Rate
- Industrial Temperature -40 to 85 Celsius
- Single 3.3V DC Input Voltage
- RoHS Compliant and lead-Free



Applications

- XGS PON
- Access and Enterprise

Product Description

This Alcatel-Lucent Nokia® compatible SFP transceiver provides 9.95Gbs/9.95Gbs XGS-PON throughput up to 20km over single-mode fiber (SMF) using a wavelength of 1270nmTx/1577nmRx via an ASC connector. It can operate at temperatures between -40 and 85C. This bidirectional unit must be used with another transceiver or network appliance of complementing wavelengths. This easy to install, hot swappable transceiver has been programmed, uniquely serialized and data-traffic and application tested to ensure that it will initialize and perform identically. Digital optical monitoring (DOM) support is also present to allow access to real-time operating parameters. We stand behind the quality of our products and proudly offer a limited lifetime warranty.

AddOn's transceivers are RoHS compliant and lead-free.

TAA refers to the Trade Agreements Act (19 U.S.C. & 2501-2581), which is intended to foster fair and open international trade. TAA requires that the U.S. Government may acquire only "U.S.-made or designated country end products."



Absolute Maximum Ratings

Parameter	Symbol	Min.	Typ.	Max.	Unit	Notes
Maximum Supply Voltage	Vcc	0		3.6	V	
Storage Ambient Temperature	Tstg	-40		85	°C	
Operating Case Temperature	Tc	-40	25	85	°C	
Relative Humidity Storage	RHstg	0		95	%	
Relative Humidity Operating	RHop	0		85	%	
Control Function Logic Levels						
Receiver Loss of Signal Logic State	Rx_LOS	0		Vcc+0.5	V	LVTTTL
Transmit Disable Logic State	Tx_Disable	0		Vcc+0.5	V	LVTTTL

Note:

Exceeding the Absolute Maximum Ratings may cause irreversible damage to the device. The device is not intended to be operated under the condition of simultaneous Absolute Maximum Ratings, a condition which may cause irreversible damage to the device.

Electrical Characteristics

Parameter	Symbol	Min.	Typ.	Max.	Unit	Notes
Power Supply Voltage	Vcc	3.135	3.30	3.465	V	
Power Supply Current	Icc			900	mA	
Transmitter						
Tx_Data Differential Input Voltage	VIH-VIL	200		1200	mV	
Tx_Disable = High (Transmitter Off/Disabled)	VIH	2.0		Vcc+0.3	V	
Tx_Disable = Low (Transmitter On/Enabled)	VIL	0		0.8	V	
Receiver						
Rx_Data Differential Output Voltage	VOH-VOL	200		900	mV	
Rx_LOS = High (Receiver Off)	VOH	2.4		3.3	V	LVTTTL
Rx_LOS = Low (Receiver On)	VOL	0		0.8	V	LVTTTL

Optical Characteristics

Parameter	Symbol	Min.	Typ.	Max.	Unit	Notes
Transmitter						
Laser Type		DFB Laser				
Transmitter Signal Rate		9.95328			Gbps	
Average Output Power	POUT	4		9	dBm	
Optical Center Wavelength	λ	1260	1270	1280	nm	
Spectral Width	$\Delta\lambda$			1	nm	
Side-Mode Suppression Mode	SMSR	30			dB	
Extinction Ratio	ER	6			dB	
Receiver						
Receiver Type		CW APD/TIA				
Receiver Signal Rate		9.95328			Gbps	
Optical Center Wavelength	λ	1575	1577	1581	nm	
Receiver Sensitivity	S			-28	dBm	1
Received Optical Overload		-9			dBm	1
Rx_LOS of Signal Assert	LOSA	-44			dBm	
Rx_LOS of Signal De-Assert	LOSD			-29	dBm	
Rx_LOS of Signal Hysteresis	LOSH	0.5		6	dB	

Notes:

1. $BER \leq 10^{-3}$, PRBS $2^{31}-1$, and ER=6dB.

Pin Descriptions

Pin	Symbol	Name/Descriptions	Notes
1	1PPS	1PPS Input/Output Pin.	5
2	Tx_Fault	Transmitter Fault. Low=Normal Operation. High=Fault Indication. This pin is pulled-up to the VccT in the module.	1
3	Tx_Disable	Transmit Disable. Low=Normal Operation. High=Disables Module.	1
4	SDA	2-Wire Serial Interface Data. Host Board shall use a pull-up resistor connected to the Host Board 3.3V.	3
5	SCL	2-Wire Serial Interface Clock. Host Board shall use a pull-up resistor connected to the Host Board 3.3V.	3
6	MOD_ABS	Pull down to ground.	2
7	Dying Gasp	Dying Gasp Indication. High=Normal Operation. Low=Power Failure.	4
8	Rx_LOS	Receiver Loss of Signal. Low=Normal Operation. High=Loss of Signal.	2, 3, 5
9	PIN9	Reserved.	
10	GND_R	Receiver Ground.	
11	GND_R	Receiver Ground.	
12	RD-	Rx_Data Output (Inverted). AC coupled inside the module.	
13	RD+	Rx_Data Output (Non-Inverted). AC coupled inside the module.	
14	GND_R	Receiver Ground.	
15	VccR	Receiver DC Power.	3.3V+/-5%
16	VccT	Transmitter DC Power.	3.3V+/-5%
17	GND_T	Transmitter Ground.	
18	TD+	Tx_Data Input (Non-Inverted). AC coupled inside the module.	
19	TD-	Tx_Data Input (Inverted). AC coupled inside the module.	
20	GND_T	Transmitter Ground.	

Notes:

1. 4.7kΩ-10kΩ pull-up resistor within the module VccT.
2. Require a pull-up resistor of 4.7kΩ-10kΩ on the host board.
3. 4.7kΩ-10kΩ pull-up resistor within the module VccR.
4. Voltage Detect Input for Dying Gasp. When the voltage on this pin is low, a Dying Gasp event is triggered. A 100kΩ resistor is used to pull-up to DC Power in the module.
5. 1PPS can be defined on PIN1, PIN8, or PIN9 as required.

Pin Assignment

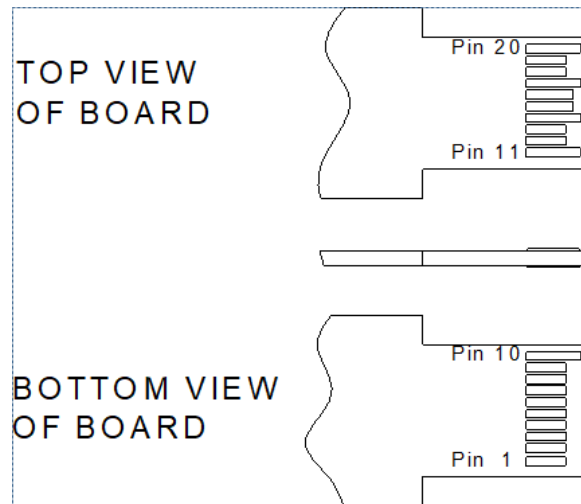

Block Diagram

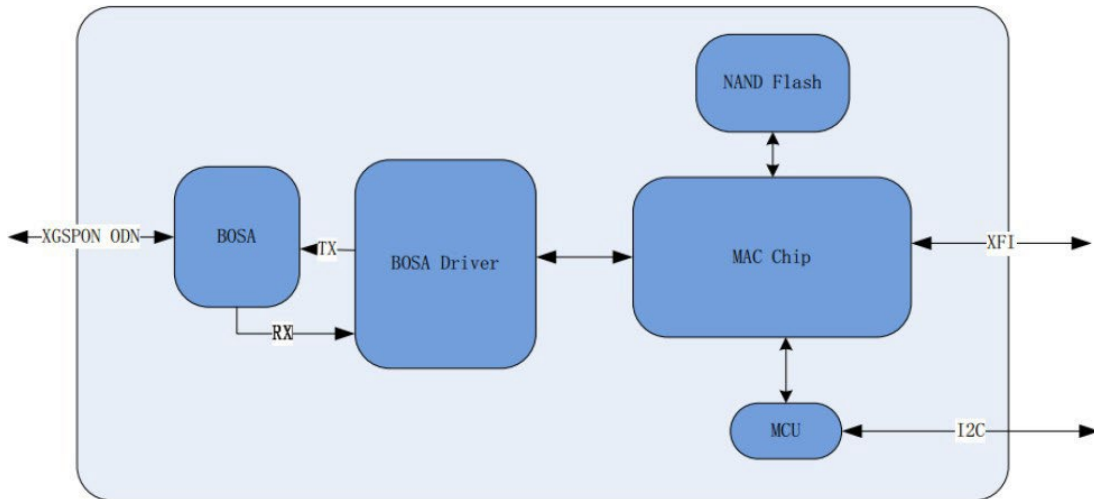

Electrical Interface

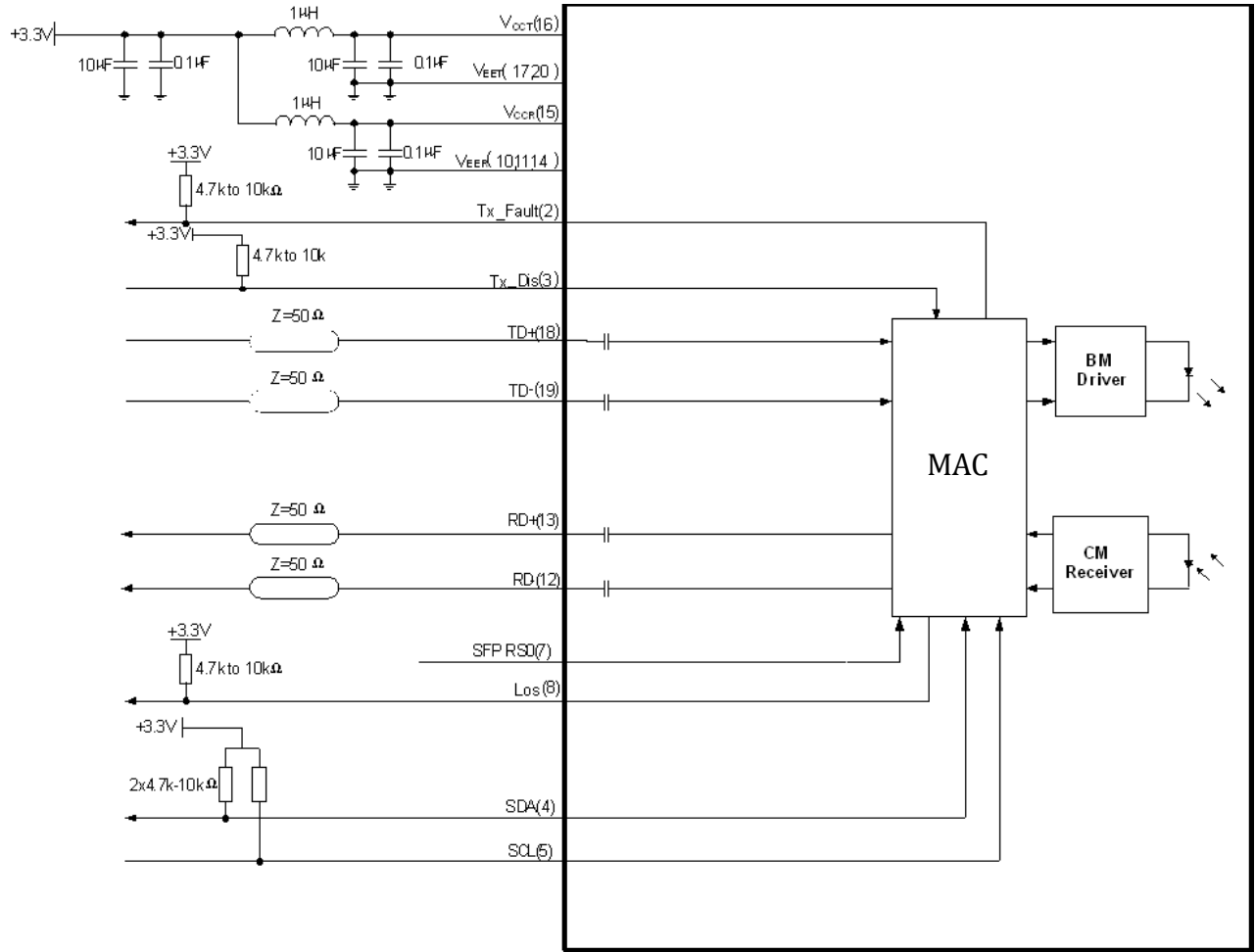

Mechanical Specifications

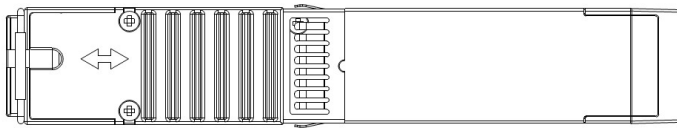
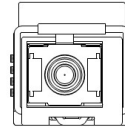
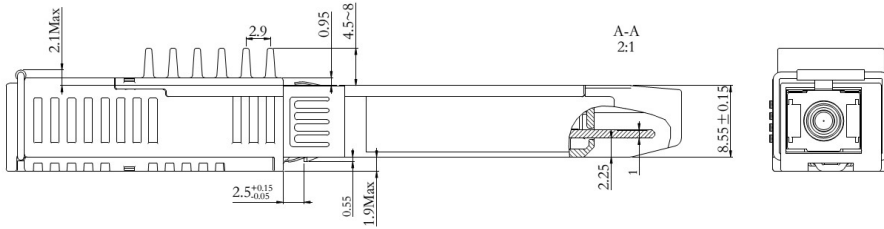
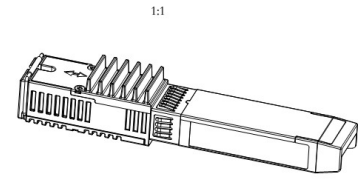
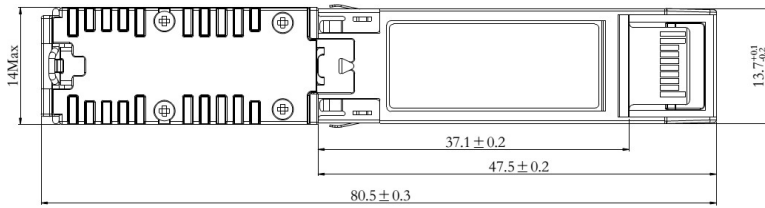

NOTES:

1. Dimensions are mm; Tolerance is $\pm 0.1\text{mm}$
2. Others are according to MSA Drawing.
3. Top heatsink height depends on heat dissipation performance.

EEPROM Information

EEPROM memory map-specific data field description is as below:

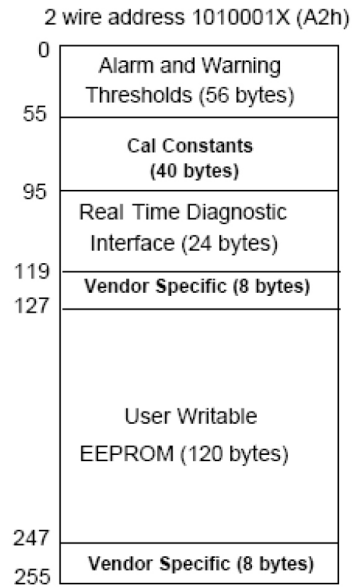
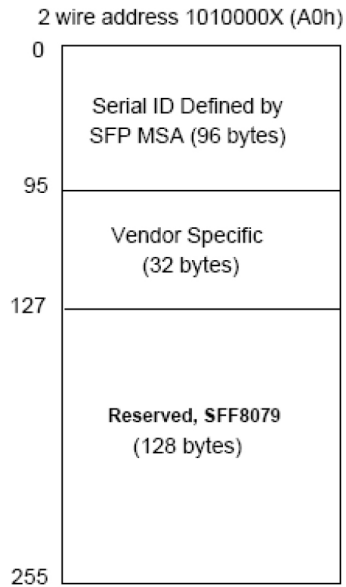

About AddOn Networks

In 1999, AddOn Networks entered the market with a single product. Our founders fulfilled a severe shortage for compatible, cost-effective optical transceivers that compete at the same performance levels as leading OEM manufacturers. Adhering to the idea of redefining service and product quality not previously had in the fiber optic networking industry, AddOn invested resources in solution design, production, fulfillment, and global support.

Combining one of the most extensive and stringent testing processes in the industry, an exceptional free tech support center, and a consistent roll-out of innovative technologies, AddOn has continually set industry standards of quality and reliability throughout its history.

Reliability is the cornerstone of any optical fiber network and is ingrained in AddOn's DNA. It has played a key role in nurturing the long-term relationships developed over the years with customers. AddOn remains committed to exceeding industry standards with certifications ranging from NEBS Level 3 to ISO 9001:2015 with every new development while maintaining the signature reliability of its products.



U.S. Headquarters

Email: sales@addonnetworks.com

Telephone: +1 877.292.1701

Fax: 949.266.9273

Europe Headquarters

Email: salesemea@addonnetworks.com

Telephone: +44 1285 842070