

SFP-XFI-LX-N-AO

Alcatel-Lucent Nokia® TAA Compatible 1000Base-LX (media interface) to 10G (host) adapting SFP+ Transceiver (SMF, 1310nm, 10km, LC)

Features

- 1310nm FP laser transmitter
- Duplex LC Connector
- Build-in PHY supporting XFI/USXGMII interface
- Receiver Loss of Signal Output
- Serial ID module on MOD (0-2)
- Single 3.3V Power Supply
- Transmitter disable input
- Class 1 laser safety certified
- RoHS compliant and Lead-Free
- Operating Temperature: 0 to 70 Celsius



Applications

- 1x Fibre Channel
- 1000Base-LX Ethernet
- Access and Enterprise

Product Description

This Alcatel-Lucent Nokia® compatible SFP transceiver provides 1000Base-LX throughput up to 10km over single-mode fiber (SMF) using a wavelength of 1310nm via an LC connector. It can operate at temperatures between 0 and 70C. Our transceiver is built to meet or exceed OEM specifications and is guaranteed to be 100% compatible with Alcatel-Lucent Nokia®. It has been programmed, uniquely serialized, and tested for data-traffic and application to ensure that it will initialize and perform identically. All of our transceivers comply with Multi-Source Agreement (MSA) standards to provide seamless network integration. This transceiver is Trade Agreements Act (TAA) compliant. We stand behind the quality of our products and proudly offer a limited lifetime warranty.

AddOn's transceivers are RoHS compliant and lead-free.

TAA refers to the Trade Agreements Act (19 U.S.C. & 2501-2581), which is intended to foster fair and open international trade. TAA requires that the U.S. Government may acquire only "U.S.-made or designated country end products."



Absolute Maximum Ratings

Parameter	Symbol	Min.	Typ.	Max.	Unit	Notes
Maximum Supply Voltage	V _{CC}			4.0	V	
Storage Temperature	T _{stg}	-40		85	°C	
Operating Case Temperature	T _c	0		70	°C	
Operating Relative Humidity	RH	0		95	%	
Power Supply Voltage	V _{CC}	3.10	3.3	3.47	V	
Supply Current	I _{CC}			800	mA	
Power Dissipation	P _{DISS}			2.0	W	

Optical Characteristics

Parameter	Symbol	Min.	Typ.	Max.	Unit	Notes
Transmitter						
Launch Optical Power	P _o	-9.5		-3.0	dBm	1
Center Wavelength	λ _C	1270		1355	nm	
Extinction Ratio	ER	9.0			dB	
Spectral Width (RMS)	Δλ			4.0	nm	
Mask Margin		10				
POUT of OFF Transmitter	P _{off}			-30	dBm	
Eye Diagram	Complies with IEEE 802.3					
Receiver						
Center Wavelength	λ _C	1260		1620	nm	
Receiver Sensitivity	S			-19	dBm	2
Overload Input Optical Power	P _{in}	-3.0			dBm	
LOS De-Assert				-20	dBm	
LOS Assert		-30			dBm	
LOS Hysteresis		0.5		5	dB	3

Notes:

1. With SMF.
2. Measured with BER<10E⁻¹².
3. The LOS Hysteresis minimizes “chatter” on the output line. In principle, Hysteresis alone does not guarantee chatter-free operation.

Pin Descriptions

Pin	Symbol	Name/Description	Notes
1	VeeT	Transmitter Signal Ground.	1
2	Tx_Fault	Transmitter Fault Out (OC).	2
3	Tx_Disable	Transmitter Disable In (LVTTTL).	3
4	SDA	Module Definition Identifiers.	4
5	SCL	Module Definition Identifiers.	4
6	MOD_ABS	Module Definition Identifiers.	4
7	RS0	Receiver Rate Select (LVTTTL). Transmitter Rate Select (LVTTTL).	5
8	LOS	Loss of Signal Out (OC).	6
9	RS1	Receiver Rate Select (LVTTTL). Transmitter Rate Select (LVTTTL).	5
10	VeeR	Receiver Signal Ground.	7
11	VeeR	Receiver Signal Ground.	7
12	RD-	Receiver Negative Data Out (CML).	8
13	RD+	Receiver Positive Data Out (CML).	9
14	VeeR	Receiver Signal Ground.	7
15	VccR	Receiver Power Supply.	10
16	VccT	Transmitter Power Supply.	10
17	VeeT	Transmitter Signal Ground.	1
18	TD+	Transmitter Positive Data In (CML).	11
19	TD-	Transmitter Negative Data In (CML).	12
20	VeeT	Transmitter Signal Ground.	1

Notes:

1. These pins should be connected to the signal ground on the host board.
2. Logic "1" Output = Transmitter Fault.
Logic "0" Output = Normal Operation.
This pin is open collector compatible and should be pulled up to the Host_Vcc with a 10kΩ resistor.
3. Logic "1" Input (or No Connection) = Laser Off.
Logic "0" Input = Laser On.
This pin is internally pulled up to the VccT with a 10kΩ resistor.
4. Serial ID with SFF-8472 Diagnostics Module Definition pins should be pulled up to the Host_Vcc with 10kΩ resistors.
5. These pins have an internal 33kΩ pull-down to ground. A signal on either of these pins will not affect module performance.
6. This pin is open collector compatible and should be pulled up to the Host_Vcc with a 10kΩ resistor.
7. These pins should be connected to the signal ground on the host board.
8. Light On = Logic "0" Output Receiver Data output is internally AC coupled and series terminated with a 50Ω resistor.
9. Light On = Logic "1" Output Receiver Data output is internally AC coupled and series terminated

with a 50Ω resistor.

10. This pin should be connected to a filtered +3.3V power supply on the host board.
11. Logic "1" Input = Light On Transmitter Data inputs are internally AC coupled and terminated with a differential 100Ω resistor.
12. Logic "0" Input = Light On Transmitter Data inputs are internally AC coupled and terminated with a differential 100Ω resistor.

Electrical Pin-Out Details

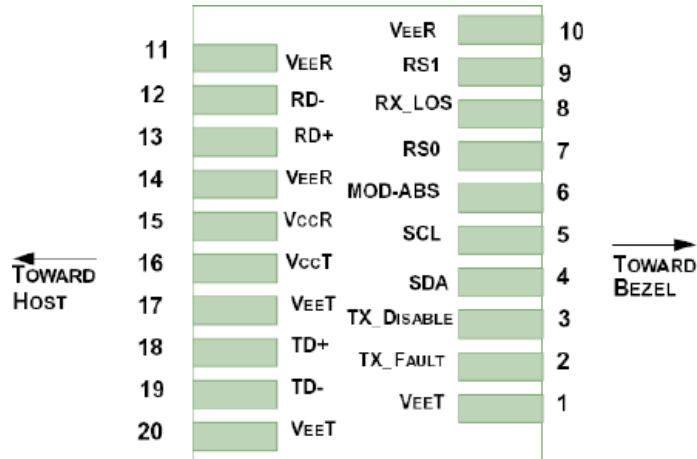

Recommended Circuit Schematic

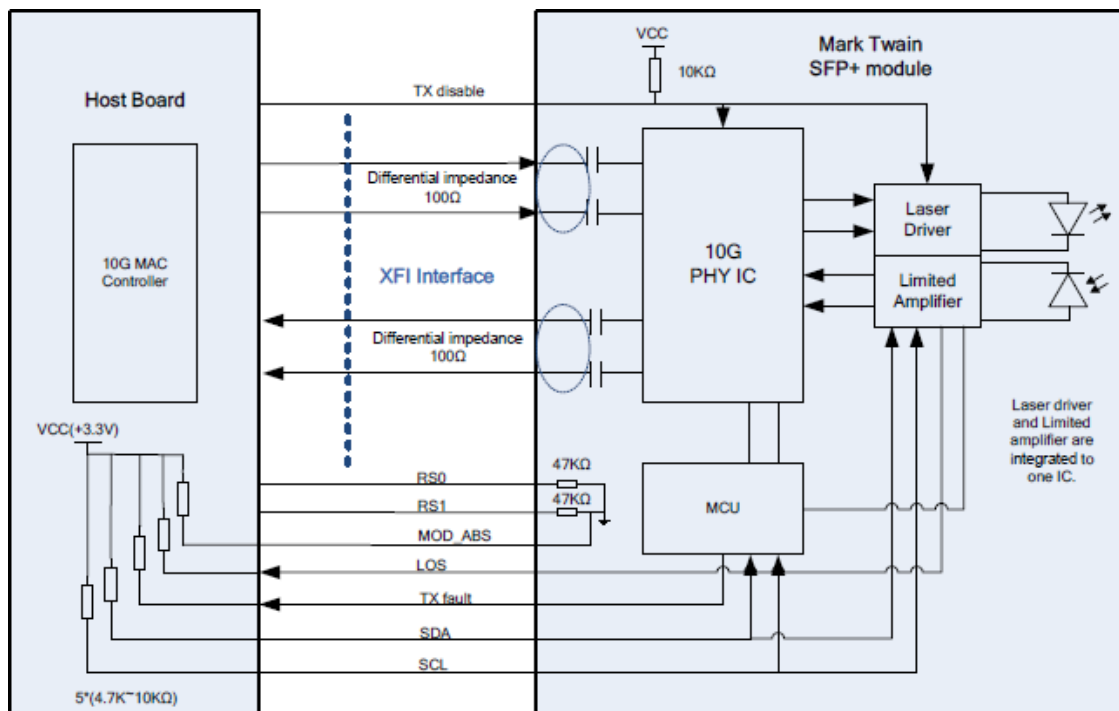

Mechanical Specifications

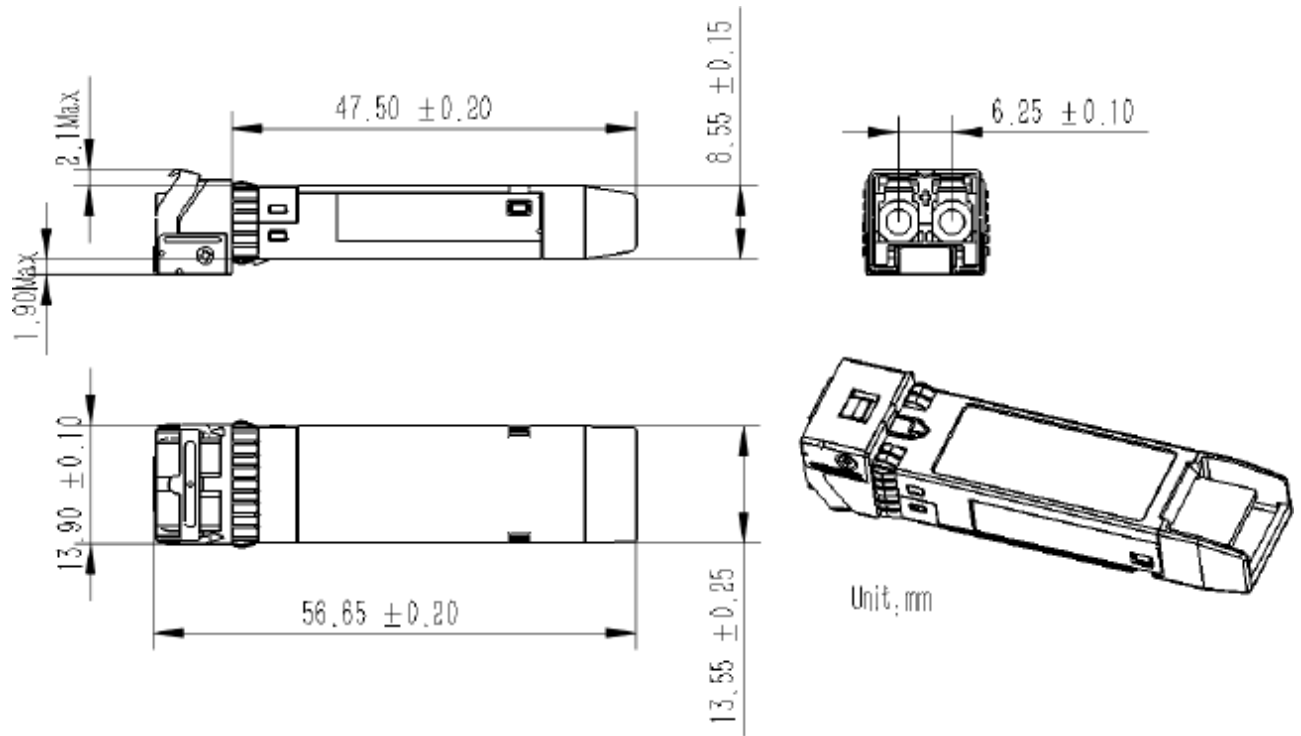

About AddOn Networks

In 1999, AddOn Networks entered the market with a single product. Our founders fulfilled a severe shortage for compatible, cost-effective optical transceivers that compete at the same performance levels as leading OEM manufacturers. Adhering to the idea of redefining service and product quality not previously had in the fiber optic networking industry, AddOn invested resources in solution design, production, fulfillment, and global support.

Combining one of the most extensive and stringent testing processes in the industry, an exceptional free tech support center, and a consistent roll-out of innovative technologies, AddOn has continually set industry standards of quality and reliability throughout its history.

Reliability is the cornerstone of any optical fiber network and is ingrained in AddOn's DNA. It has played a key role in nurturing the long-term relationships developed over the years with customers. AddOn remains committed to exceeding industry standards with certifications ranging from NEBS Level 3 to ISO 9001:2015 with every new development while maintaining the signature reliability of its products.



U.S. Headquarters

Email: sales@addonnetworks.com

Telephone: +1 877.292.1701

Fax: 949.266.9273

Europe Headquarters

Email: salesemea@addonnetworks.com

Telephone: +44 1285 842070