

SFP-25GB-BXU23-80-N-AO

Alcatel-Lucent Nokia® Compatible TAA 25GBase-BX SFP28 Transceiver (SMF, 1295.56nmTx/1309.14nmRx, 80km, LC, DOM)

Features

- Supports Data Rate Up to 25.78125Gbps
- Hot-Pluggable SFP Footprint
- Compliant to IEEE 802.3cc, SFF-8472, and SFF-8419
- Up to 80km on SMF
- EML Tx and Integrated SOA and PIN TIA Rx
- Single LC Connector
- Operating Temperature: 0 to 70 Celsius
- Power Consumption: 2.2W
- RoHS Compliant and Lead-Free



Applications

- 25GBase Ethernet
- Access and Enterprise

Product Description

This Alcatel-Lucent Nokia® compatible SFP28 transceiver provides 25GBase-BX throughput up to 80km over single-mode fiber (SMF) using a wavelength of 1295.56nmTx/1309.14nmRx via an LC connector. This bidirectional unit must be used with another transceiver or network appliance of complementing wavelengths. It is guaranteed to be 100% compatible with the equivalent Alcatel-Lucent Nokia® transceiver. This easy to install, hot swappable transceiver has been programmed, uniquely serialized and data-traffic and application tested to ensure that it will initialize and perform identically. Digital optical monitoring (DOM) support is also present to allow access to real-time operating parameters. This transceiver is Trade Agreements Act (TAA) compliant. We stand behind the quality of our products and proudly offer a limited lifetime warranty.

AddOn's transceivers are RoHS compliant and lead-free.

TAA refers to the Trade Agreements Act (19 U.S.C. & 2501-2581), which is intended to foster fair and open international trade. TAA requires that the U.S. Government may acquire only "U.S.-made or designated country end products."



Absolute Maximum Ratings

Parameter	Symbol	Min.	Typ.	Max.	Unit	Notes
Operating Case Temperature	Tc	0		70	°C	
Storage Temperature	Tstg	-40		85	°C	
Relative Humidity – Storage	RHstg	5		95	%	
Relative Humidity – Operating	RHc	5		85	%	
Supply Voltage	Vcc	0		3.6	V	
Transmission Distance	TD			80	km	Over SMF

Electrical Characteristics

Parameter	Symbol	Min.	Typ.	Max.	Unit	Notes
Power Supply Voltage	Vcc	3.135	3.3	3.465	V	
Power Supply Current	Icc			660	mA	
Power Consumption	PC			2.2	W	
Transmitter						
Differential Input Resistance	R_RDIN	90	100	110	Ω	
Input Differential Voltage	R_VDIFF			900	mVp-p	
Tx_Disable	Normal Operating	VIL	-0.3	0.8	V	
	Laser Disable	VIH	2.0	Vcc+0.3	V	
Receiver						
Differential Resistance	T_RD	90	100	110	Ω	
Output Differential Voltage	T_VDIFF			900	mVp-p	
Differential Termination Resistance Mismatch	T_RDM			10	%	
Rx_LOS	Normal Operating	VOL	-0.3	0.4	V	
	Loss of Signal	VOH	2	Host_Vcc	V	

Optical Characteristics

Parameter	Symbol	Min.	Typ.	Max.	Unit	Notes
Transmitter						
Center Wavelength	λ_C	1294.53	1295.56	1296.59	nm	
Average Output Power	POUT	2		7	dBm	1
Average Output Power (Laser Off)	POFF			-30	dBm	
Spectral Width (-20dB)	$\Delta\lambda$			1	nm	
Side-Mode Suppression Ratio	SMSR	30			dB	
Extinction Ratio	ER	8			dB	
RIN _{20OMA}	RIN			-128	dB/Hz	
Transmitter Dispersion Penalty	TDP			2.7	dB	
Receiver						
Center Wavelength	λ_C	1308.09	1309.14	1310.19	nm	
Receiver Sensitivity	PIN			-27	dBm	1
Optical Power Overload	PIN(SAT)	-4			dBm	
Damage Threshold		3			dBm	2
Rx_LOS of Signal Assert	PA	-40			dBm	
Rx_LOS of Signal De-Assert	PD			-28	dBm	
Rx_LOS of Signal Hysteresis	PHY	0.5		2	dB	
Optical Return Loss Tolerance	ORLT	20			dB	

Notes:

1. Test pattern: PRBS31. BER<5x10⁻⁵.
2. The receiver shall be able to tolerate, without damage, continuous exposure to an optical input signal having this average power level. The receiver does not have to operate correctly at this input power.

Pin Descriptions

Pin	Symbol	Name/Description	Notes
1	VeeT	Transmitter Ground.	1
2	Tx_Fault	Transmitter Fault Indication.	2
3	Tx_Disable	Transmitter Disable. Turns off transmitter laser output.	3
4	SDA	2-Wire Serial Interface Data Input/Output (SDA).	4
5	SCL	2-Wire Serial Interface Clock Input (SCL).	4
6	MOD_ABS	Module Absent. Connect to VeeR or VeeT in the module.	4
7	RS0	Rate Select 0. Optionally control SFP+ receiver. When "high," input data rate >4.5Gbps; when "low," input rate ≤4.5Gbps.	5
8	LOS	Receiver Loss of Signal.	6
9	RS1	Rate Select 1. Optionally control SFP+ transmitter. When "high," input data rate >4.5Gbps. When "low," input rate ≤4.5Gbps.	1
10	VeeR	Receiver Ground.	1
11	VeeR	Receiver Ground.	1
12	RD-	Receiver Inverted Data Output.	
13	RD+	Receiver Non-Inverted Data Output.	
14	VeeR	Receiver Ground.	1
15	VccR	+3.3V Receiver Power Supply.	
16	VccT	+3.3V Transmitter Power Supply.	
17	VeeT	Transmitter Ground.	1
18	TD+	Transmitter Inverted Data Output.	
19	TD-	Transmitter Non-Inverted Data Output.	
20	VeeT	Transmitter Ground.	1

Notes:

1. Circuit ground is internally isolated from chassis ground
2. Tx_FAULT is an open collector/drain output that should be pulled up with a 4.7kΩ to 10kΩ resistor on the host board if intended for use. Pull-up voltage should be between 2.0V to Vcc+0.3V. A "high" output indicates a transmitter fault caused by either the Tx bias current or the Tx output power exceeding the preset alarm thresholds. A "low" output indicates normal operation. In the "low" state, the output is pulled to <0.8V.
3. Laser output disabled on Tx_DIS >2.0V or open, enabled on Tx_DIS <0.8V.
4. Should be pulled up with 4.7kΩ- 10kΩ host board to a voltage between 2.0V and 3.6V. MOD_ABS pulls line low to indicate module is plugged in.
5. Internally pulled down per SFF-8431 Rev 4.1.
6. LOS is open collector output. It should be pulled up with 4.7kΩ – 10kΩ on host board to a voltage between 2.0V and 3.6V. "Logic 0" indicates normal operation. "Logic 1" indicates loss of signal.

Pin-Out Details

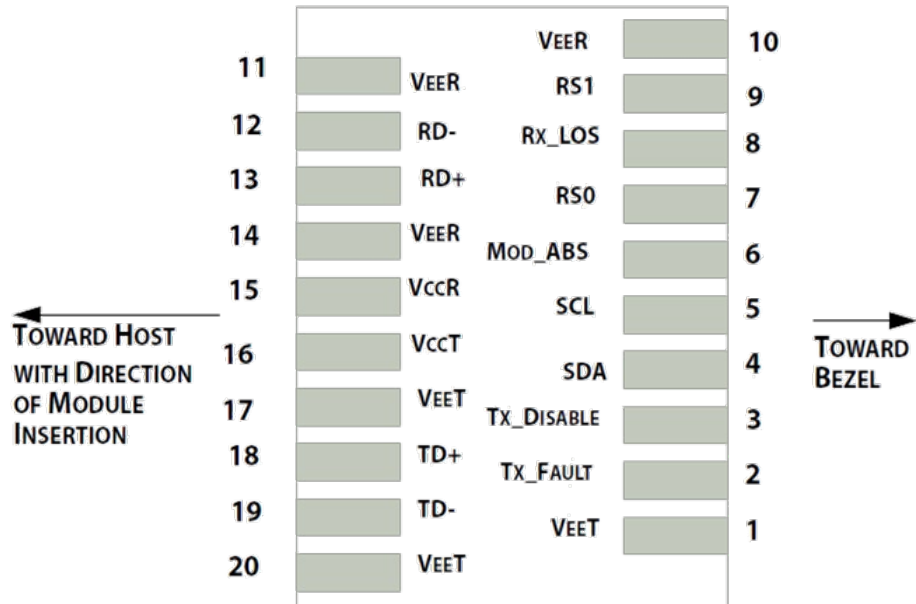

Recommended Circuit Schematic

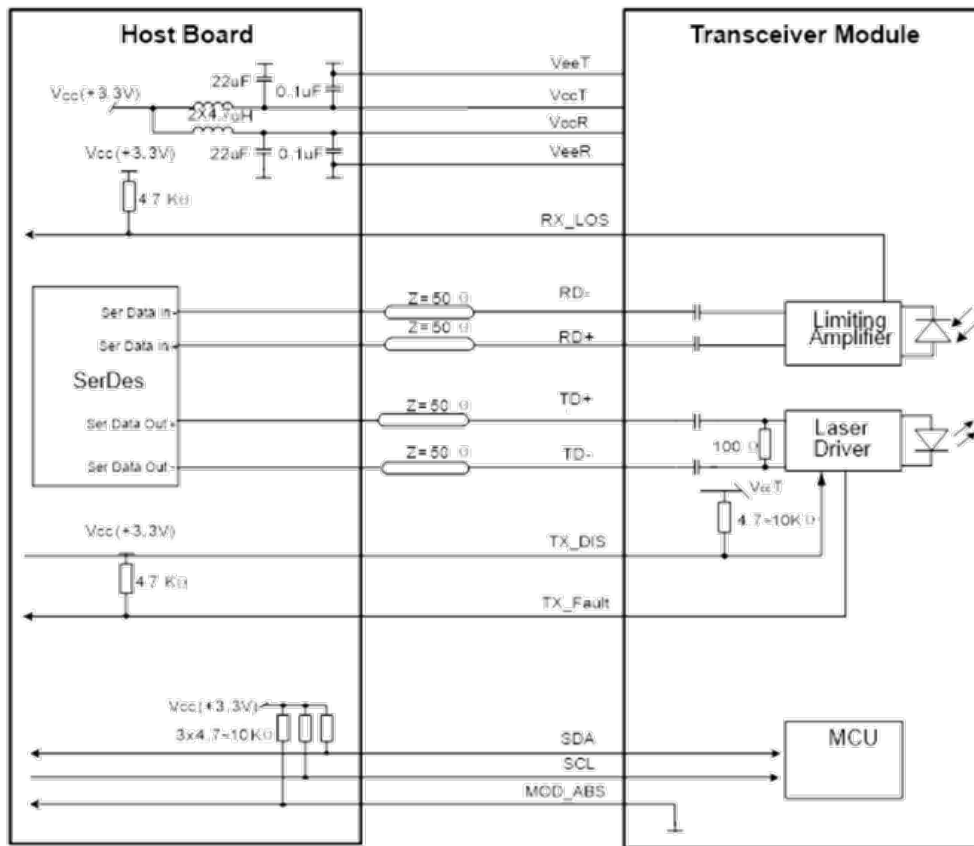

Mechanical Specifications

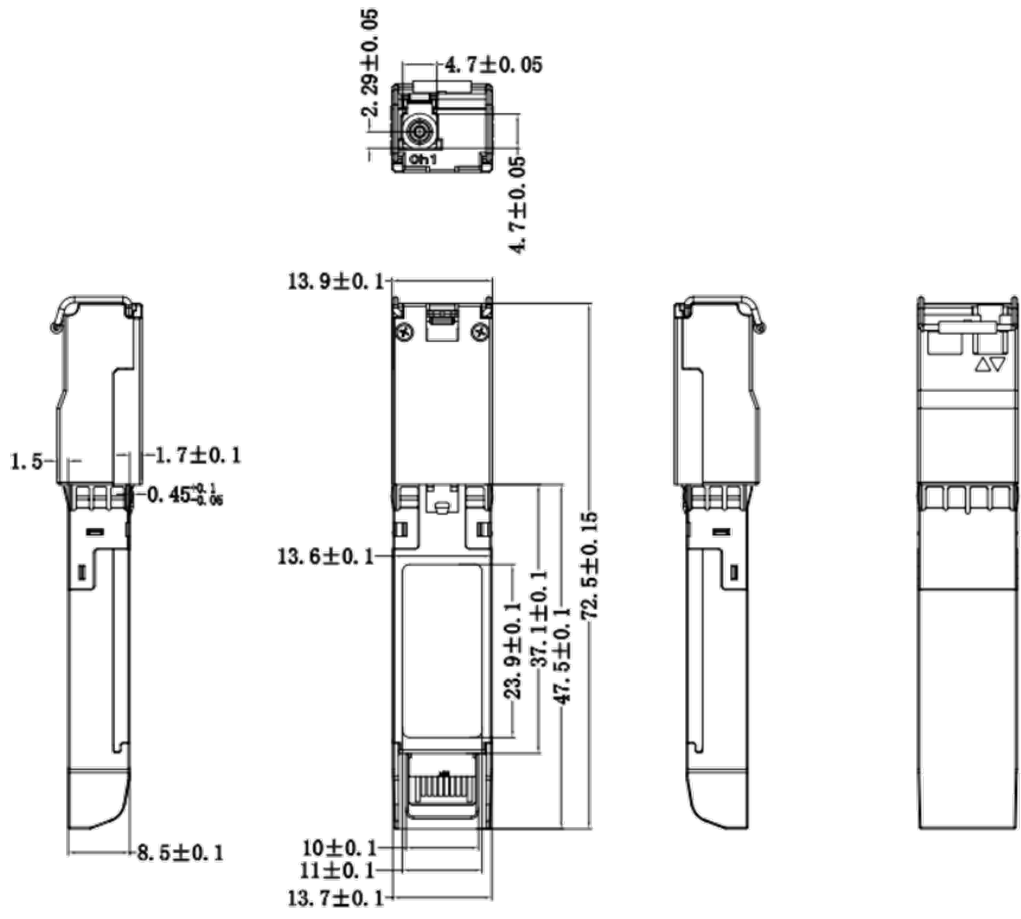

About AddOn Networks

In 1999, AddOn Networks entered the market with a single product. Our founders fulfilled a severe shortage for compatible, cost-effective optical transceivers that compete at the same performance levels as leading OEM manufacturers. Adhering to the idea of redefining service and product quality not previously had in the fiber optic networking industry, AddOn invested resources in solution design, production, fulfillment, and global support.

Combining one of the most extensive and stringent testing processes in the industry, an exceptional free tech support center, and a consistent roll-out of innovative technologies, AddOn has continually set industry standards of quality and reliability throughout its history.

Reliability is the cornerstone of any optical fiber network and is ingrained in AddOn's DNA. It has played a key role in nurturing the long-term relationships developed over the years with customers. AddOn remains committed to exceeding industry standards with certifications ranging from NEBS Level 3 to ISO 9001:2015 with every new development while maintaining the signature reliability of its products.



U.S. Headquarters

Email: sales@addonnetworks.com

Telephone: +1 877.292.1701

Fax: 949.266.9273

Europe Headquarters

Email: salesemea@addonnetworks.com

Telephone: +44 1285 842070