

3AL82152AA-C

Alcatel-Lucent Nokia® 3AL82152AA Compatible TAA OTU-4-ER4 100GbE Dual-Rate QSFP28 Transceiver (SMF, 1295nm to 1309nm, 40km, LC, DOM)

Features:

- SFF-8665 Compliance
- Duplex LC Connector
- Single-mode Fiber
- Commercial Temperature 0 to 70 Celsius
- Hot Pluggable
- Metal with Lower EMI
- Excellent ESD Protection
- RoHS Compliant and Lead Free



Applications:

- 100GBase Ethernet
- OTN OTU4
- Access and Enterprise

Product Description

This Alcatel-Lucent Nokia® 3AL82152AA compatible QSFP28 transceiver provides OTU-4-ER4 100GbE Dual-Rate ER4 throughput up to 40km over single-mode fiber (SMF) using a wavelength of 1295nm to 1309nm via an LC connector. It is guaranteed to be 100% compatible with the equivalent Alcatel-Lucent Nokia® transceiver. This easy to install, hot swappable transceiver has been programmed, uniquely serialized and data-traffic and application tested to ensure that it will initialize and perform identically. Digital optical monitoring (DOM) support is also present to allow access to real-time operating parameters. This transceiver is Trade Agreements Act (TAA) compliant. We stand behind the quality of our products and proudly offer a limited lifetime warranty.

ProLabs' transceivers are RoHS compliant and lead-free.

TAA refers to the Trade Agreements Act (19 U.S.C. & 2501-2581), which is intended to foster fair and open international trade. TAA requires that the U.S. Government may acquire only "U.S.-made or designated country end products.")



Regulatory Compliance

- ESD to the Electrical PINs: compatible with MIL-STD-883E Method 3015.4
- ESD to the LC Receptacle: compatible with IEC 61000-4-3
- EMI/EMC compatible with FCC Part 15 Subpart B Rules, EN55022:2010
- Laser Eye Safety compatible with FDA 21CFR, EN60950-1& EN (IEC) 60825-1,2
- RoHS compliant with EU RoHS 2.0 directive 2015/863/EU

Absolute Maximum Ratings

Parameter	Symbol	Min.	Typ.	Max.	Unit
Maximum Supply Voltage	Vcc	-0.5		3.6	V
Storage Temperature	TS	-40		85	°C
Operating Case Temperature	Tc	0		70	°C
Operating Relative Humidity	RH	5		85	%
Rx Damage Threshold, per Lane	PRdmg	-3.0			dBm
Data Rate	DR		103.125		Gb/s
Link Distance with G.652 (without FEC)	D1			30	km
Link Distance with G.652 (with FEC)	D2			40	km

Electrical Characteristics

Parameter	Symbol	Min.	Typ.	Max.	Unit	Notes
Supply Voltage	Vcc	3.14	3.3	3.47	V	
Supply Current	Icc			1.36	A	
Power Consumption	P			4.5	W	
Transmitter						
Input differential impedance	Rin		100		Ω	1
Differential data input swing	Vin,pp	180		1000	mV	
Transmit Disable Voltage	VD	Vcc-1.3		Vcc	V	
Transmit Enable Voltage	VEN	Vee		Vee+ 0.8	V	2
Receiver						
Differential data output swing	Vout,pp	300		850	mV	3
LOS Fault	VLOS fault	Vcc-1.3		VccHOST	V	4
LOS Normal	VLOS norm	Vee		Vee+0.8	V	4

Notes:

1. Connected directly to TX data input pins. AC coupled thereafter.

2. Optional for TX disable
3. Into 100 ohms differential termination
4. Loss Of Signal is LVTTTL. Logic 0 indicates normal operation; logic 1 indicates no signal detected

Optical Characteristics

Parameter	Symbol	Min.	Typ.	Max.	Unit	Notes
Transmitter						
Signaling rate, each lane	DRPL	25.78125 ±100 ppm			Gb/s	
Four Lane Wavelength Range	λ1	1294.53	1295.56	1296.59	nm	
	λ2	1299.02	1300.05	1301.09	nm	
	λ3	1303.54	1304.58	1305.63	nm	
	λ4	1308.09	1309.14	1310.19	nm	
Total launch power	Pout			12.5	dBm	
Average launch power, each lane	Pavg	-2.5		6.5	dBm	
Optical modulation amplitude, each lane (OMA)	OMA	0.5		6.5	dBm	
Extinction ratio	ER	4.5			dB	
Side-mode suppression ratio	SMSR	30			dB	
Average launch power of OFF transmitter, per lane	POFF			-30	dBm	
RIN	RIN			-130	dB/Hz	
Transmitter reflectance	TR			-12	dB	
Transmitter eye mask {X1, X2, X3, Y1, Y2, Y3}	Mt	{0.25, 0.4, 0.45, 0.25, 0.28, 0.4}				1
Receiver						
Four Lane Wavelength Range	λ1	1294.53	1295.56	1296.59	nm	
	λ2	1299.02	1300.05	1301.09	nm	
	λ3	1303.54	1304.58	1305.63	nm	
	λ4	1308.09	1309.14	1310.19	nm	
Receive Rate for Each Lane	Pavg	25.78125 ±100 ppm			Gb/s	
Damage Threshold, each Lane	THd			-7	dBm	
Average receive power, each lane (max)	PSAT			-7	dBm	
Average receive power, each lane (min)	Pin			-18.5	dBm	2
Average receive power, each lane (min)	Pin			-14.5	dBm	3
Return Loss	RL			-26	dB	
Los De-Assert	Pd			-23	dBm	
Los Assert	Pa	-33			dBm	

Loss Hysteresis	Pd-Pa	0.5		6	dBm	
-----------------	-------	-----	--	---	-----	--

Notes:

1. Hit ratio 5×10^{-5}
2. BER = $5 \times 10^{-5,2}$
3. BER = $1 \times 10^{-12,2}$

Electrical Pin-out Details

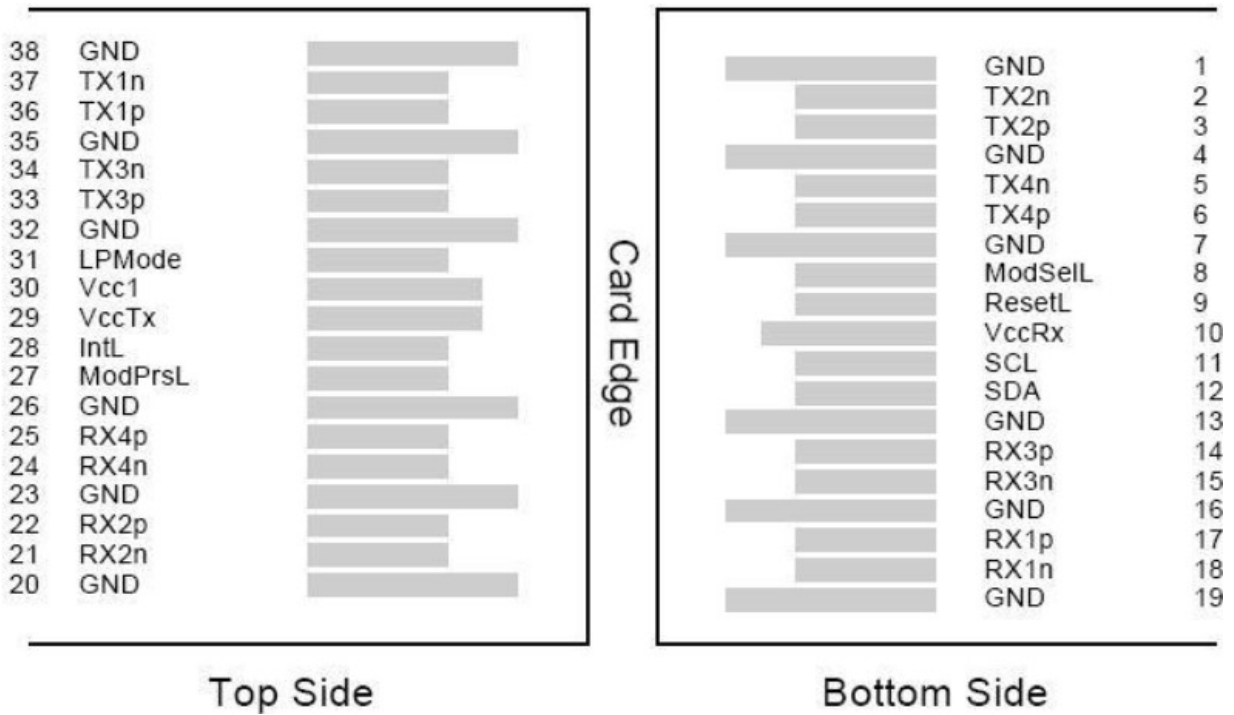

Pin Descriptions

Pin	Symbol	Name/Descriptions	Ref.
1	GND	Transmitter Ground (Common with Receiver Ground)	1
2	Tx2-	Transmitter Inverted Data Input	
3	Tx2+	Transmitter Non-Inverted Data output	
4	GND	Transmitter Ground (Common with Receiver Ground)	1
5	Tx4-	Transmitter Inverted Data Input	
6	Tx4+	Transmitter Non-Inverted Data output	
7	GND	Transmitter Ground (Common with Receiver Ground)	1
8	ModSelL	Module Select	2
9	ResetL	Module Reset	2
10	VccRx	3.3V Power Supply Receiver	
11	SCL	2-Wire serial Interface Clock	2
12	SDA	2-Wire serial Interface Data	2
13	GND	Transmitter Ground (Common with Receiver Ground)	1
14	Rx3+	Receiver Non-Inverted Data Output	
15	Rx3-	Receiver Inverted Data Output	
16	GND	Transmitter Ground (Common with Receiver Ground)	1
17	Rx1+	Receiver Non-Inverted Data Output	
18	Rx1-	Receiver Inverted Data Output	
19	GND	Transmitter Ground (Common with Receiver Ground)	1
20	GND	Transmitter Ground (Common with Receiver Ground)	1
21	Rx2-	Receiver Inverted Data Output	
22	Rx2+	Receiver Non-Inverted Data Output	
23	GND	Transmitter Ground (Common with Receiver Ground)	1
24	Rx4-	Receiver Inverted Data Output	1
25	Rx4+	Receiver Non-Inverted Data Output	
26	GND	Transmitter Ground (Common with Receiver Ground)	1
27	ModPrsl	Module Present	
28	IntL	Interrupt	2
29	VccTx	3.3V power supply transmitter	
30	Vcc1	3.3V power supply	
31	LPMODE	Low Power Mode	2
32	GND	Transmitter Ground (Common with Receiver Ground)	1
33	Tx3+	Transmitter Non-Inverted Data Input	
34	Tx3-	Transmitter Inverted Data Output	

35	GND	Transmitter Ground (Common with Receiver Ground)	1
36	Tx1+	Transmitter Non-Inverted Data Input	
37	Tx1-	Transmitter Inverted Data Output	
38	GND	Transmitter Ground (Common with Receiver Ground)	1

Notes:

1. The module signal grounds are isolated from the module case.
2. This is an open collector/drain output that on the host board requires a 4.7KΩ to 10KΩ pull-up resistor to Vcchost.

Recommended Power Supply Filter Network

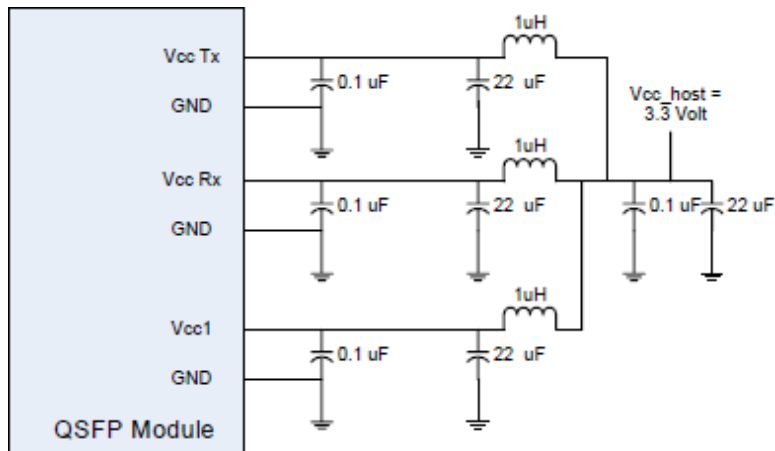

Functional Diagram

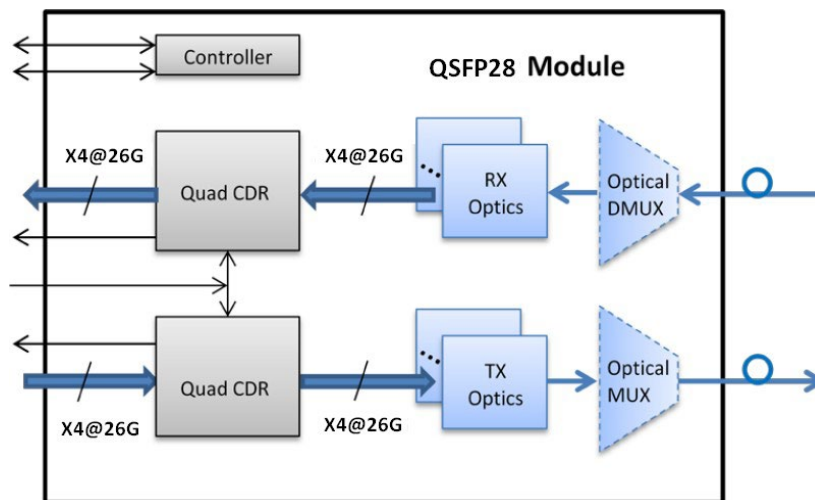

Mechanical Specifications

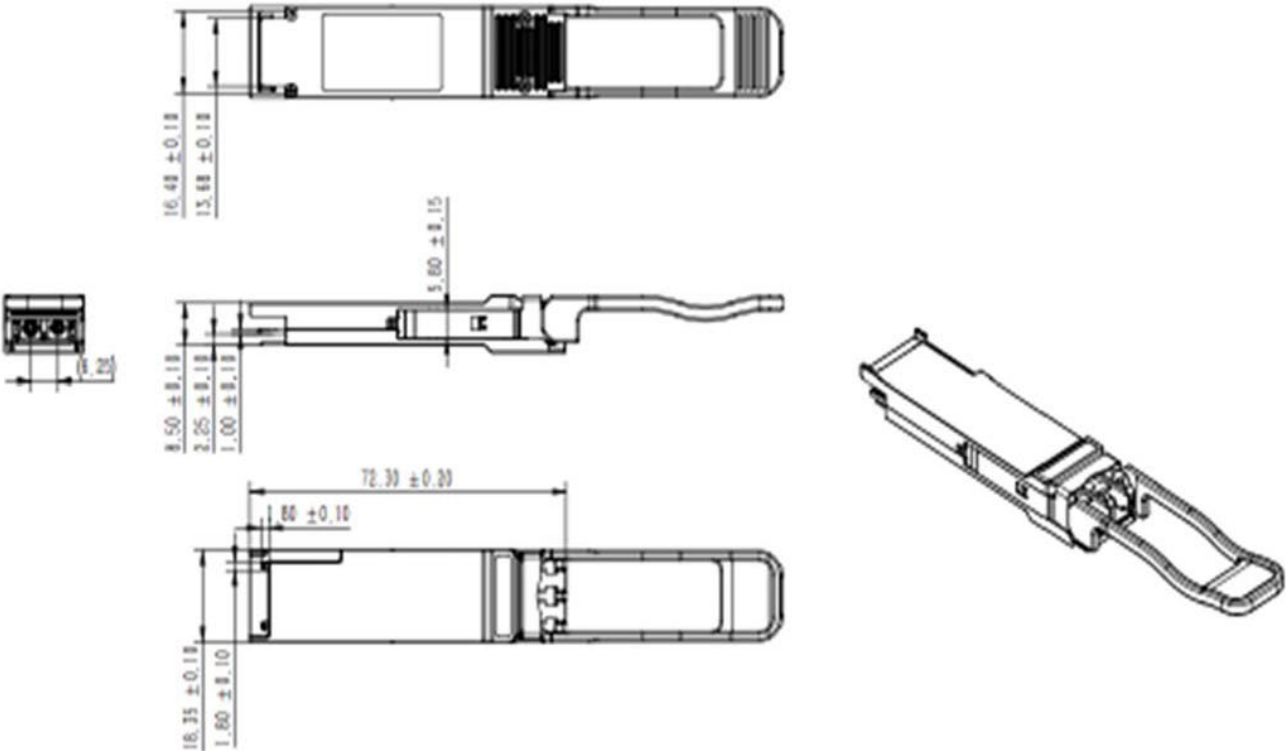

About ProLabs

Our extensive experience comes as standard. For over 20 years ProLabs has delivered optical connectivity solutions that give our customers freedom and choice through our ability to provide seamless interoperability. At the heart of our company is the ability to provide state-of-the-art optical transport and connectivity solutions that are compatible with more than 100 optical switching and transport platforms.

A Complete Portfolio of Network Solutions

ProLabs is focused on innovations in optical transport and connectivity. The combination of our knowledge of optics and networking equipment enables ProLabs to be your single source for optical transport and connectivity solutions from 100Mb to 1.6T while providing innovative solutions that increase network efficiency. We provide the optical connectivity expertise that is compatible with and enhances your switching and transport equipment.

The Trusted Partner

Customer service is our number one value. ProLabs has invested in people, labs and manufacturing capacity to ensure compatible products, and immediate answers to your questions. With Engineering and Manufacturing offices in the U.K. and U.S. augmented by field offices throughout the U.S., U.K. and Asia, ProLabs is able to be our customers best advocate 24 hours a day.



Contact Information

ProLabs US

Email: sales@prolabs.com

Telephone: 952-852-0252

ProLabs UK

Email: salessupport@prolabs.com

Telephone: +44 1285 719 600