

3FE53441FC-C

Alcatel-Lucent Nokia® 3FE53441FC Compatible TAA GPON OLT SFP C++ Transceiver (1490nmTx/1310nmRx, 2.5Gbps/1.25Gbps, 39dBm, SC, Rugged)

Features:

- Integrated Single Fiber Bi-Directional Optical Subassembly
- 1310nm Burst-Mode APD/TIA Receiver
- 1490nm Continuous DFB Laser Transmitter (with WDM)
- 3.3V Single Power Supply
- Low Power Consumption
- Single SC Receptacle Optical Interface Compliant
- CML Compatible Data Input and Output
- LVTTTL Receiver Reset Control and Burst-Power-Detect Indication
- Operating Temperature: -40 to 85 Celsius
- RoHS Compliant and Lead-Free



Applications:

- GPON
- Access and Enterprise

Product Description

This Alcatel-Lucent Nokia® 3FE53441FC compatible SFP transceiver provides 2.4Gbps/1.2Gbps-C++ throughput up to 60km over single-mode fiber (SMF) using a wavelength of 1490nmTx/1310nmRx via a SC connector. It is also capable of withstanding rugged environments and can operate at temperatures between -40C to +85C. It is guaranteed to be 100% compatible with the equivalent Alcatel-Lucent Nokia® transceiver. This easy to install, hot swappable transceiver has been programmed, uniquely serialized and data-traffic and application tested to ensure that it will initialize and perform identically. Digital optical monitoring (DOM) support is also present to allow access to real-time operating parameters. This transceiver is Trade Agreements Act (TAA) compliant. We stand behind the quality of our products and proudly offer a limited lifetime warranty.

ProLabs' transceivers are RoHS compliant and lead-free.

TAA refers to the Trade Agreements Act (19 U.S.C. & 2501-2581), which is intended to foster fair and open international trade. TAA requires that the U.S. Government may acquire only "U.S.-made or designated country end products.")



Absolute Maximum Ratings

Parameter	Symbol	Min.	Typ.	Max.	Unit	Notes
Operating Temperature Range	Tc	-40		85	°C	
Storage Temperature Range	Tstg	-40		85	°C	
Relative Humidity	RH	5		95	%	
Supply Voltage	Vcc	0		4.0	V	
Pin Input Voltage		GND		Vcc	V	
Receiver Damage Threshold		+3			dBm	
Data Rate (Tx Side)			2488.32		Mbps	
Data Rate (Rx Side)			1244.16		Mbps	

Electrical Characteristics

Parameter	Symbol	Min.	Typ.	Max.	Unit	Notes
Power Supply Voltage	Vcc	3.135	3.3	3.465	V	
Supply Current	Icc			500	mA	
LVPECL Differential Data Input Swing		200		1600	mV	1
LVPECL Differential Data Output Swing		400		1600	mV	1
Differential Data Input Impedance			100		Ω	1
Input Signal Level (LVTTTL-H)		2.0		Vcc	V	
Input Signal Level (LVTTTL-L)		0		0.8	V	
Output Signal Level (LVTTTL-H)		2.4		Vcc	V	
Output Signal Level (LVTTTL-L)		0		0.4	V	

Notes:

1. AC coupled internally.

Optical Characteristics

Parameter	Symbol	Min.	Typ.	Max.	Unit	Notes
Transmitter						
Data Rate			2488.32		Mbps	
Center Wavelength Range	λ_C	1480	1490	1500	nm	1
Spectral Width (-20dB)	$\Delta\lambda$			1	nm	
Side-Mode Suppression Ratio	SMSR	30			dB	
Launch Optical Power (BOL)	PBOL	+5.0		+9	dBm	2
Off Level Light				-39	dBm	3
Extinction Ratio	ER	8.2			dB	4
Total Jitter	TJ			0.2	UI	
Rise/Fall Time (20-80%)	Tr/Tf			250	ps	5
RIN ₁₅ OMA				-115	dB/Hz	
Optical Return Loss Tolerance				15	dB	
Maximum Reflectance				-12	dB	7
Eye Diagram	Compliant with ITU-T G.984.2					4, 12
Receiver						
Data Rate			1244.16		Mbps	
Receiver Sensitivity (EOL)	Rx_Sen			-33	dBm	6
Overload Input Optical Power		-14			dBm	6
CID Immunity		72			Bits	
Center Wavelength Range	λ_C	1260	1310	1360	nm	
PDL				0.5	dB	9
Reflected Optical Isolation		32			dB	10
Reflected Overlay Optical Isolation		36			dB	11
Optical Cross-Talk				-46	dB	12
Reflectance of Rx				-20	dB	9
Differential Power Range				15	dB	
LOS Response Time Assert/De-Assert				500/900	ns	
Signal Detect (LVTTTL)	Optical De-Assert	-45			dBm	
	Optical Assert			-34		
Signal Detect Hysteresis		0.5		6	dB	
Measurement Accuracy of Received Burst Optical Power (Range from -10dBm to -34dBm)		-3		+3	dB	
Burst Optical Power Conversion Settling Time (Trigger Delay)	BOPCS Time	25			ns	
Burst Optical Power Conversion Holding Time	Holding Time	350			ns	
Burst Optical Power Conversion Time				500	us	

Notes:

1. DFB-LD.
2. Coupled into 9/125 μ m SMF.
3. Measured without data input.
4. Measured with PRBS $2^{23}-1$ test pattern @2.488Gbps.
5. Measured with the Bessel-Thompson filter off.
6. Measured with PRBS $2^{23}-1$ test pattern @1.244Gbps with Tx on, ER=10dB, BER $\leq 10E^{-10}$, preamble length is 25 Bytes, and reset length is 10 Bytes.
7. $\lambda=1.49\mu$ m.
8. 1260~1360nm.
9. From 1480~1500nm relative to 1260~1360nm.
10. From 1539~1565nm relative to 1260~1360nm.
11. Result can be read out from rising edge of the trigger pulse.
12. Eye mask of diagram.

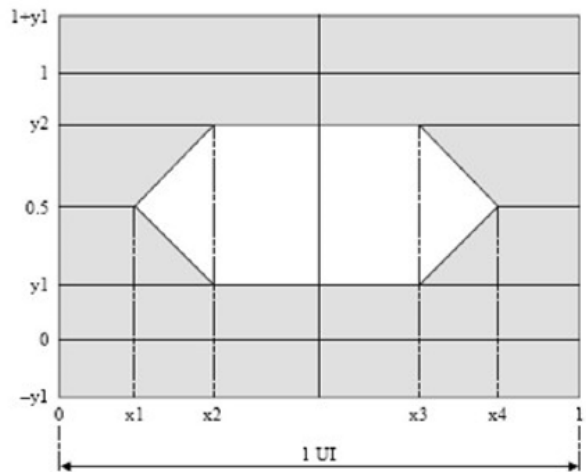

	1244.16 Mbit/s	2488.32 Mbit/s
x1/x4	0.28/0.72	---
x2/x3	0.40/0.60	---
x3 - x2	---	0.2
y1/y2	0.20/0.80	0.25/0.75

Pin Descriptions

Pin	Symbol	Name/Description	Plug Sequence	Notes
1	VeeT	Transmitter Ground.	1	
2	Tx_Fault	Transmitter Fault Indication.	3	1
3	Tx_Disable	Transmitter Disable. Module disables on “high” or “open.”	3	2
4	MOD_DEF2	Module Definition 2. 2-Wire Serial ID Interface.	3	3
5	MOD_DEF1	Module Definition 1. 2-Wire Serial ID Interface.	3	3
6	MOD_DEF0	Module Definition 0. 2-Wire Serial ID Interface.	3	3
7	Reset	Reset Signal Input.	3	8
8	BPD	Burst Power Detect (Active High).	3	4
9	Trigger	Trigger Input of Burst Signal Packet Received.	3	9
10	VeeR	Receiver Ground.	1	
11	VeeR	Receiver Ground.	1	
12	RD-	Inverted Received Data Out.	3	5
13	RD+	Received Data Out.	3	5
14	VeeR	Receiver Ground.	1	
15	VccR	+3.3V ± 5% Receiver Power Supply.	2	6
16	VccT	+3.3V ± 5% Transmitter Power Supply.	2	6
17	VeeT	Transmitter Ground.	1	
18	TD+	Transmitter Data In.	3	7
19	TD-	Inverted Transmitter Data In.	3	7
20	VeeT	Transmitter Ground.	1	

Notes:

1. Tx_Fault is open collector/drain output that should be pulled up externally with a 4.7kΩ to 10kΩ resistor on the host board to supply $V_{ccT}+0.3V$ or $V_{ccR}+0.3V$. When “high,” this output indicates a laser fault of some kind. “Low” indicates normal operation. In the low state, the output will be pulled to <math><0.8V</math>.
2. Tx_Disable input is used to shut down the laser output per the state table below. It is pulled up within the module with a 4.7kΩ to 10kΩ resistor:
 - Low (0V – 0.8V): Transmitter On
 - Between (0.8V and 2V): Undefined
 - High (2.0V – VccT): Transmitter Disabled
 - Open: Transmitter Disabled.
3. MOD_DEF0, 1, & 2. These are the module definition pins. They should be pulled up with a 4.7kΩ to 10kΩ resistor on the host board to supply less than $V_{ccT}+0.3V$ or $V_{ccR}+0.3V$.
 - MOD_DEF0 is grounded by the module to indicate that the module is present.
 - MOD_DEF1 is the clock line of the 2-wire serial interface for optional serial ID.
 - MOD_DEF2 is the data line of the 2-wire serial interface for optional serial ID.
4. BPD (Burst Power Detect) is pulled up internally with a 10kΩ resistor to the VccR. When “low,” this output indicates that the received optical power is below the worst-case receiver sensitivity (as defined by the standard in use). “High” indicates normal operation. In the low state, the output will be pulled to <math><0.8V</math>.

5. RD-/+. These are the differential receiver outputs. They are DC-coupled with 100Ω differential lines which should be terminated with 100Ω differential at the user SERDES. The DC coupling is done inside the module.
6. VccR and VccT are the receiver and transmitter power supplies. They are defined as 3.3V±5% at the SFP connector pin. The in-rush current will typically be no more than 30mA above steady state supply current after 500ns.
7. TD-/+. These are the differential transmitter inputs. They are AC-coupled, differential lines with 100Ω differential termination inside the module. The AC coupling is done inside the module and is thus not required on host board.
8. Reset input compliant with LVTTTL. It will be asserted “high” at the end of a burst packet.
9. Trigger input compliant with LVTTTL. One positive pulse will issue a burst optical power conversion.

Host Board

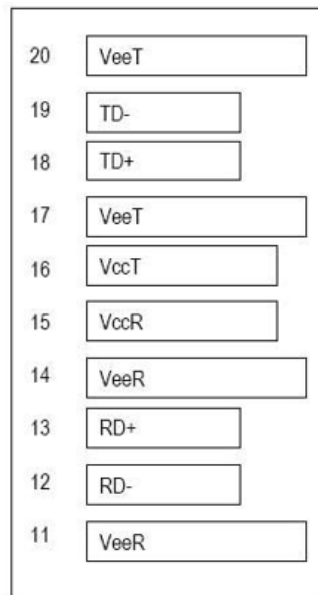

Top of Board

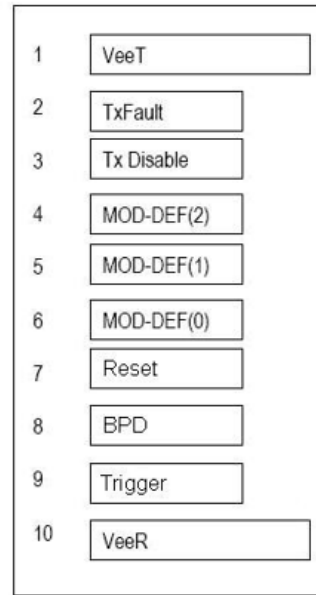

Bottom of Board (as viewed thru top of board)

Trigger Sequence

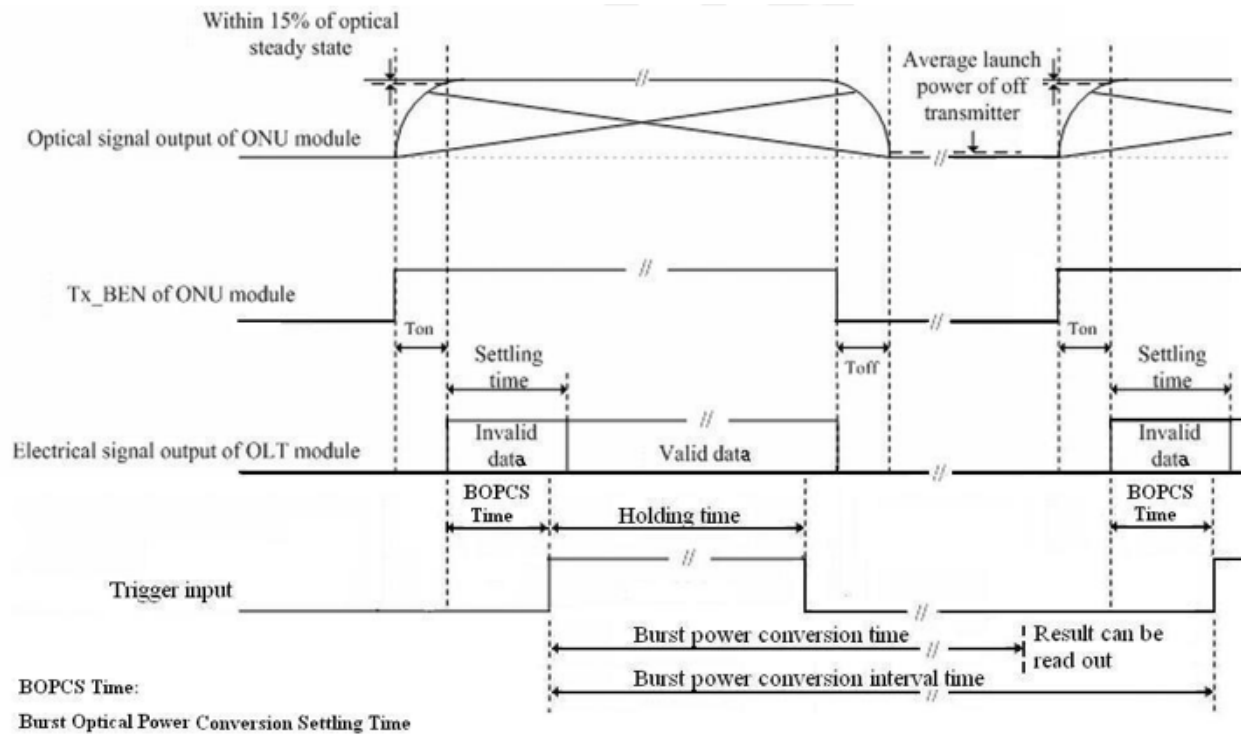

Block Diagram

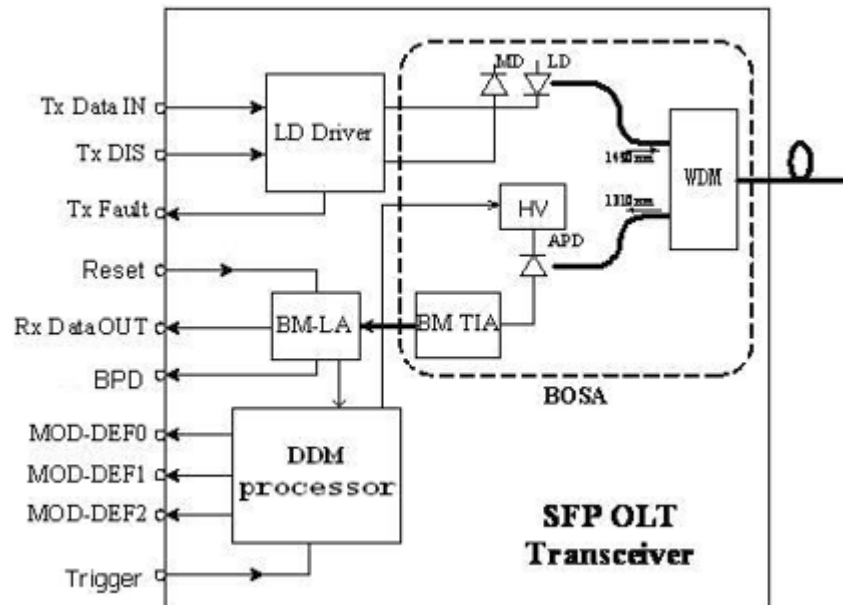

Recommended Circuit Schematic

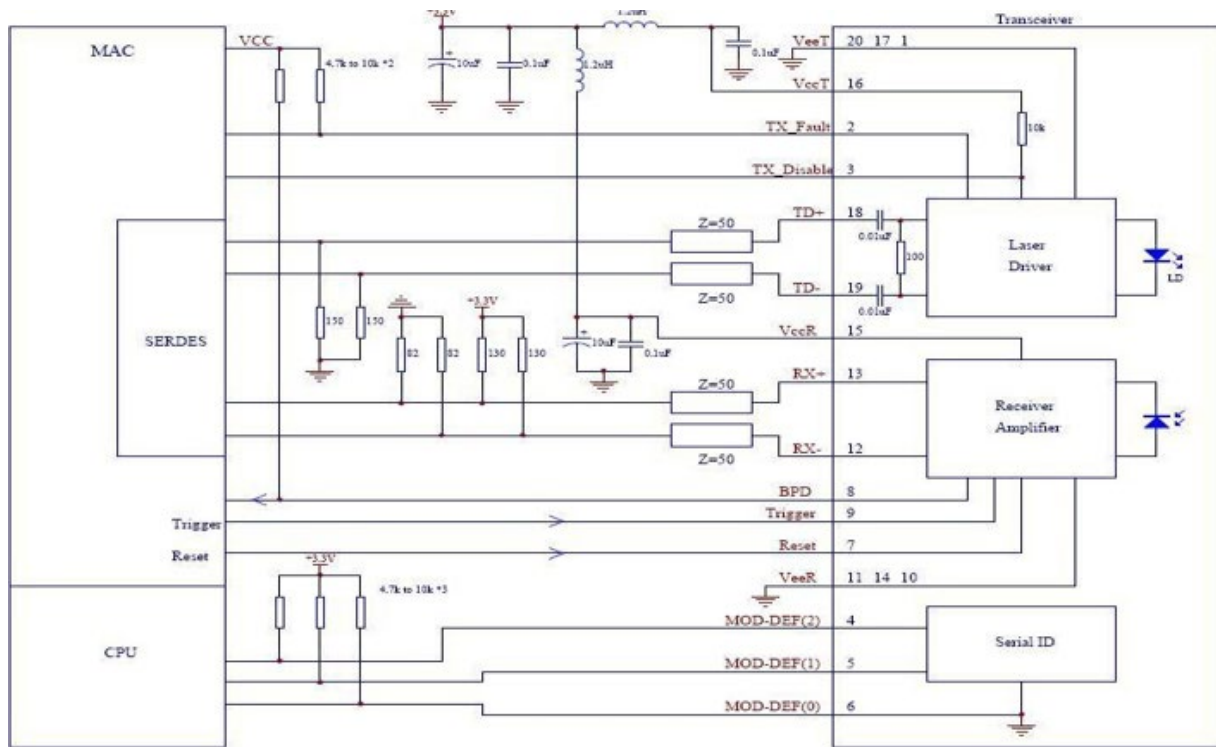

Mechanical Specifications

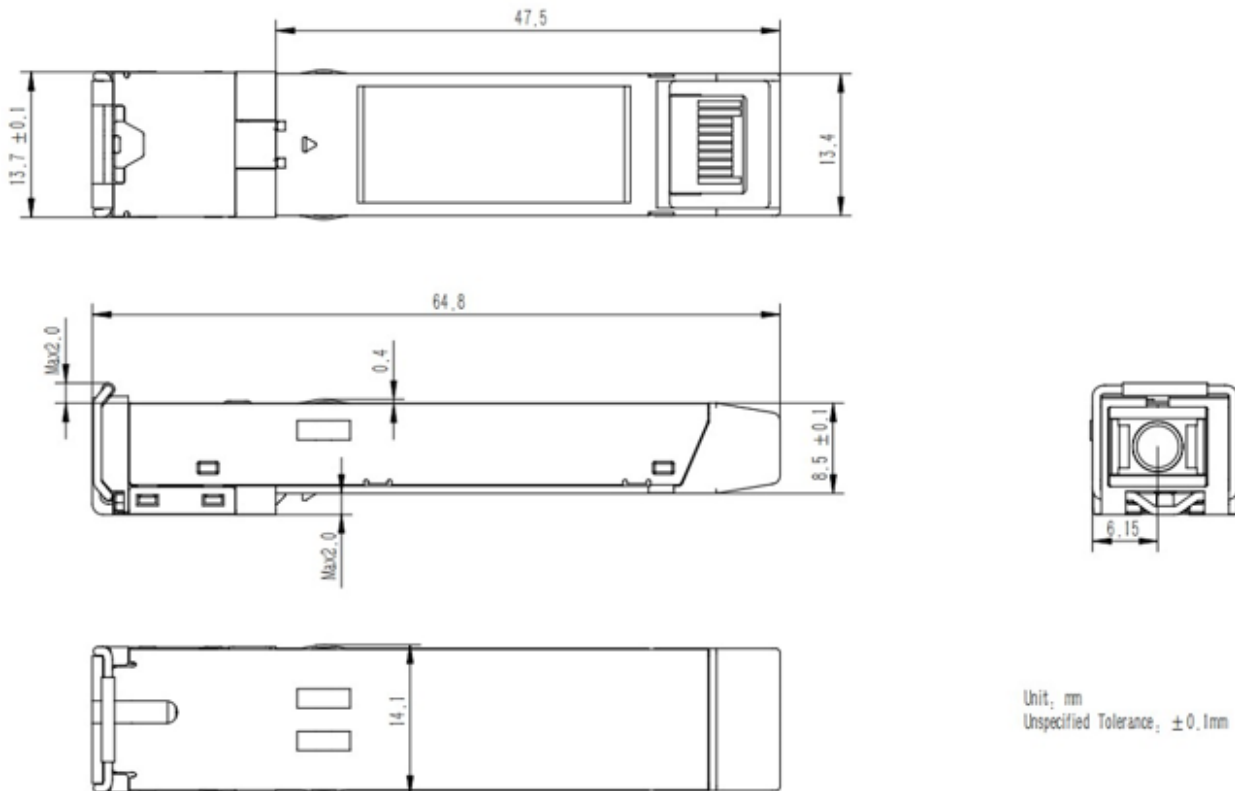

About ProLabs

Our extensive experience comes as standard. For over 20 years ProLabs has delivered optical connectivity solutions that give our customers freedom and choice through our ability to provide seamless interoperability. At the heart of our company is the ability to provide state-of-the-art optical transport and connectivity solutions that are compatible with more than 100 optical switching and transport platforms.

A Complete Portfolio of Network Solutions

ProLabs is focused on innovations in optical transport and connectivity. The combination of our knowledge of optics and networking equipment enables ProLabs to be your single source for optical transport and connectivity solutions from 100Mb to 1.6T while providing innovative solutions that increase network efficiency. We provide the optical connectivity expertise that is compatible with and enhances your switching and transport equipment.

The Trusted Partner

Customer service is our number one value. ProLabs has invested in people, labs and manufacturing capacity to ensure compatible products, and immediate answers to your questions. With Engineering and Manufacturing offices in the U.K. and U.S. augmented by field offices throughout the U.S., U.K. and Asia, ProLabs is able to be our customers best advocate 24 hours a day.



Contact Information

ProLabs US

Email: sales@prolabs.com

Telephone: 952-852-0252

ProLabs UK

Email: salessupport@prolabs.com

Telephone: +44 1285 719 600