

3HE11245AA-C

Alcatel-Lucent Nokia® 3HE11245AA Compatible TAA 1000Base-BX SFP Transceiver (SMF, 1490nmTx/1570nmRx, 80km, LC, DOM)

Features:

- SFF-8472 and MSA Compliant
- Duplex LC Connector
- Single-mode fiber
- Single 3.3V power supply
- Commercial Temperature 0 to 70 Celsius
- Hot Pluggable
- Metal with Lower EMI
- Excellent ESD Protection
- RoHS compliant and Lead-Free

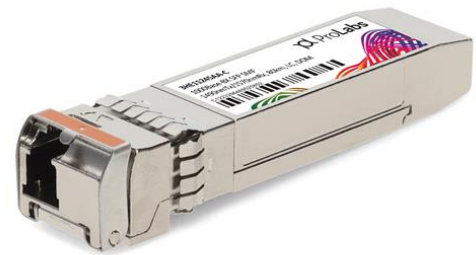

Applications:

- 1000Base-BX Ethernet
- Access and Enterprise

Product Description

This Alcatel-Lucent Nokia® 3HE11245AA compatible SFP transceiver provides 1000Base-BX throughput up to 80km over single-mode fiber (SMF) using a wavelength of 1490nmTx/1570nmRx via an LC connector. This bidirectional unit must be used with another transceiver or network appliance of complementing wavelengths. It can operate at temperatures between 0 and 70C. Our transceiver is built to meet or exceed OEM specifications and is guaranteed to be 100% compatible with Alcatel-Lucent Nokia®. It has been programmed, uniquely serialized, and tested for data-traffic and application to ensure that it will initialize and perform identically. All of our transceivers comply with Multi-Source Agreement (MSA) standards to provide seamless network integration. Additional product features include Digital Optical Monitoring (DOM) support which allows access to real-time operating parameters. We stand behind the quality of our products and proudly offer a limited lifetime warranty.

ProLabs' transceivers are RoHS compliant and lead-free.

TAA refers to the Trade Agreements Act (19 U.S.C. & 2501-2581), which is intended to foster fair and open international trade. TAA requires that the U.S. Government may acquire only "U.S.-made or designated country end products.")



Absolute Maximum Ratings

Parameter	Symbol	Min.	Typ.	Max.	Unit	Notes
Maximum Supply Voltage	V _{cc}	-0.5		3.6	V	
Storage Temperature	T _{stg}	-40		85	°C	
Operating Case Temperature	T _c	0		70	°C	
Operating Relative Humidity	RH	5		85	%	
Power Supply Current	I _{cc}			300	mA	
Data Rate	GBE		1.25		Gbps	
	FC		1.063			

Electrical Characteristics

Parameter	Symbol	Min.	Typ.	Max.	Unit	Notes
Supply Voltage	V _{cc}	3.15	3.3	3.47	V	
9µm Core Diameter SMF	L		80		km	
Transmitter						
Differential LVPECL Inputs	V _{IN}	400		1800	mVp-p	1
Differential Input Impedance	Z _{IN}	90	100	110	Ω	2
Tx_Disable	Disable	2		V _{cc} +0.3	V	
	Enable	0		0.8	V	
Tx_Fault	Fault	2		V _{cc} +0.3	V	
	Normal	0		0.8	V	
Receiver						
Differential LVPECL Outputs	V _{OUT}	400		2000	mVp-p	3
Differential Output Impedance	Z _{OUT}	90	100	110	Ω	
Tx_Disable Assert Time	T _{off}			10	us	
Rx_LOS	LOS	2		V _{cc} +0.3	V	
	Normal	0		0.8	V	
MOD_DEF(0.2)	VOH	2.5		V _{cc} +0.3	V	4
	VOL	0		0.5	V	

Notes:

1. AC coupled inputs. LVPECL logic. Internally AC coupled.
2. R_{IN}>100kΩ @ DC.
3. AC coupled outputs. LVPECL logic. Internally AC coupled.
4. With serial ID.

Optical Characteristics

Parameter	Symbol	Min.	Typ.	Max.	Unit	Notes
Transmitter						
Center Wavelength	λ_C	1470	1490	1510	nm	
Spectral Width (-20dB)	$\Delta\lambda$			1	nm	
Average Output Power	POUT	-5		0	dBm	1
Side-Mode Suppression Ratio	SMSR	30			dB	
Extinction Ratio	ER	9			dB	
Rise/Fall Time (20-80%)	T_r/T_f			0.26	ns	
POUT @ Tx_Disable Asserted	POUT			-35	dBm	
Total Jitter	TJ			0.43	UI	
Output Optical Eye	Compliant with IEEE 802.3					2
Receiver						
Center Wavelength	λ_C	1550	1570	1590	nm	
Receiver Sensitivity	Pmin			-24	dBm	3
Receiver Overload	Pmax	-3			dBm	
LOS De-Assert	LOSD			-25	dBm	
LOS Assert	LOSA	-35			dBm	
LOS Hysteresis		1			dB	

Notes:

1. Output power is power coupled into a 9/125 μ m single-mode fiber.
2. Filtered, measured with a PRBS 2⁷-1 test pattern @1250Mbps.
3. Minimum average optical power is measured at BER less than 1E⁻¹², with 1.25Gbps, 2⁷-1 PRBS, and ER=9dB.

Pin Descriptions

Pin	Symbol	Name/Description	Plug Seq.	Notes
1	VeeT	Transmitter Ground.	1	5
2	Tx_Fault	Transmitter Fault Indication.	3	1
3	Tx_Disable	Transmitter Disable. Module disables on "high" or "open."	3	2
4	MOD_DEF2	Module Definition 2. 2-Wire Serial ID Interface.	3	3
5	MOD_DEF1	Module Definition 1. 2-Wire Serial ID Interface.	3	3
6	MOD_DEF0	Module Definition 0. Grounded within the module.	3	3
7	Rate Select	Not Connected. Function Not Available.	3	
8	LOS	Loss of Signal.	3	4
9	VeeR	Receiver Ground.	1	5
10	VeeR	Receiver Ground.	1	5
11	VeeR	Receiver Ground.	1	5
12	RD-	Inverse Received Data Out.	3	6
13	RD+	Received Data Out.	3	7
14	VeeR	Receiver Ground.	1	5
15	VccR	3.3 ± 5% Receiver Power.	2	7
16	VccT	3.3 ± 5% Transmitter Power.	2	7
17	VeeT	Transmitter Ground.	1	5
18	TD+	Transmitter Data In.	3	8
19	TD-	Inverse Transmitter Data In.	3	8
20	VeeT	Transmitter Ground.	1	5

Notes:

- Tx_Fault is an open collector/drain output that should be pulled up with a 4.7kΩ to 10kΩ resistor on the host board. Pull-up voltage between 2.0V and VccT/R+0.3V. When "high," output indicates a laser fault of some kind. "Low" indicates normal operation. In the low state, the output will be pulled to <0.8V.
- Tx_Disable is an input that is used to shut down the transmitter optical output. It is pulled up within the module with a 4.7kΩ to 10kΩ resistor. Its states are:
 - Low (0V – 0.8V): Transmitter On.
 - (>0.8V and <2.0V): Undefined.
 - High (2.0V – 3.465V): Transmitter Disabled.
 - Open: Transmitter Disabled.
- MOD_DEF0, 1, & 2. These are the module definition pins. They should be pulled up with a 4.7kΩ to 10kΩ resistor on the host board. The pull-up voltage shall be VccT or VccR.
 - MOD_DEF0 is grounded by the module to indicate that the module is present.
 - MOD_DEF1 is the clock line of the 2-wire serial interface for optional serial ID.
 - MOD_DEF2 is the data line of the 2-wire serial interface for optional serial ID.

4. LOS (Loss of Signal) is an open collector/drain output that should be pulled up with a 4.7kΩ to 10kΩ resistor. Pull-up voltage between 2.0V and $V_{ccT}/R+0.3V$. When "high," this output indicates the received optical power is below the worst-case receiver sensitivity (as defined by the standard in use). "Low" indicates normal operation. In the low state, the output will be pulled to <0.8V.
5. VeeR and VeeT may be internally connected within the SFP module.
6. RD-/+ . These are the differential receiver outputs. They are AC-coupled, 100Ω differential lines which should be terminated with 100Ω (differential) at the user SERDES. The AC coupling is done inside the module and is thus not required on the host board. The voltage swing on these lines will be between 400mV and 2000mV differential (200mV and 1000mV single-ended) when properly terminated.
7. VccR and VccT are the receiver and transmitter power supplies. They are defined as $3.3V \pm 5\%$ at the SFP connector pin. Maximum supply current is 300mA. Recommended host board power supply filtering is shown below. Inductors with DC resistance of less than 1Ω should be used in order to maintain the required voltage at the SFP input pin with 3.3V supply voltage. When the recommended supply filtering network is used, hot-plugging of the SFP transceiver module will result in an in-rush current of no more than 30mA greater than the steady state value. VccR and VccT may be internally connected within the SFP transceiver module.
8. TD-/+ . These are the differential transmitter inputs. They are AC-coupled, differential lines with 100 differential terminations inside the module. The AC coupling is done inside the module and is thus not required on the host board. The inputs will accept differential swings of 400mV-2000mV (200mV-1000mV single-ended).

Pin Connectors

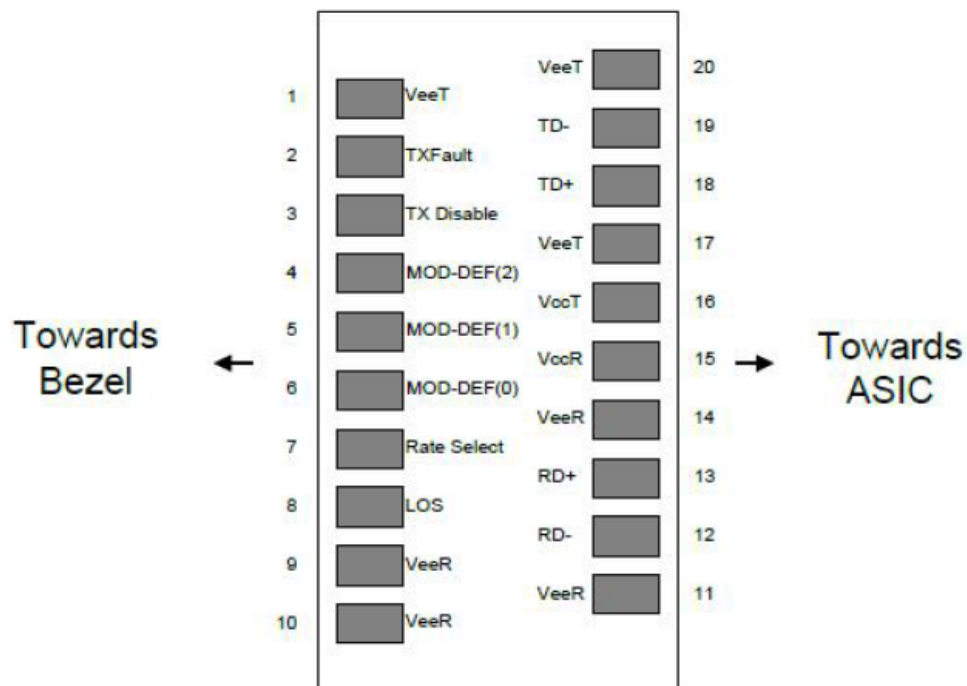

Recommended Circuit Schematic

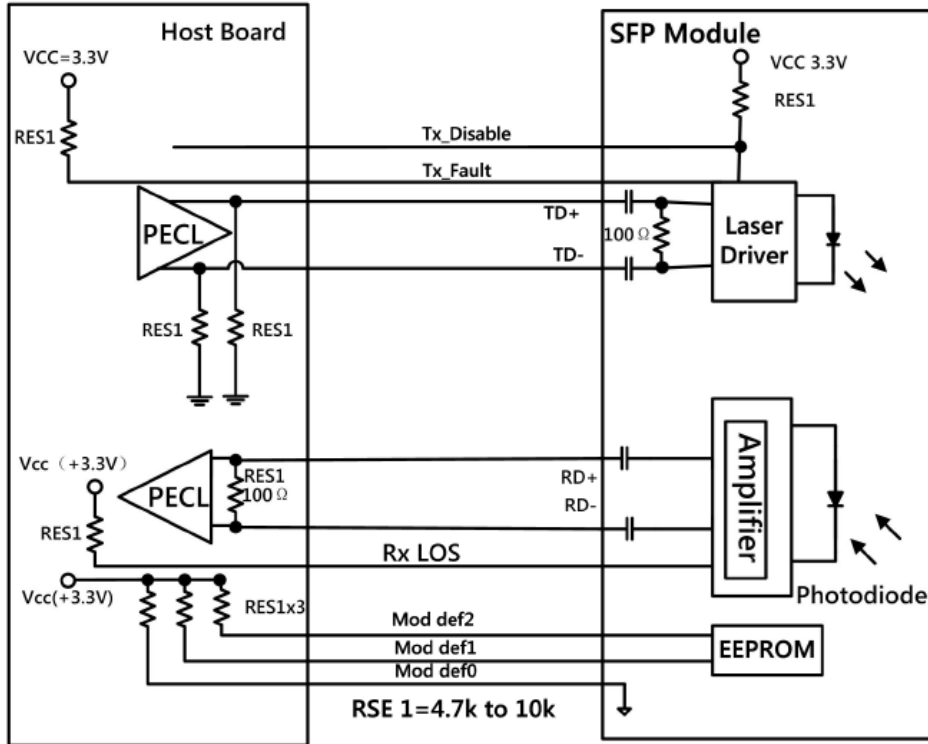

Mechanical Specifications

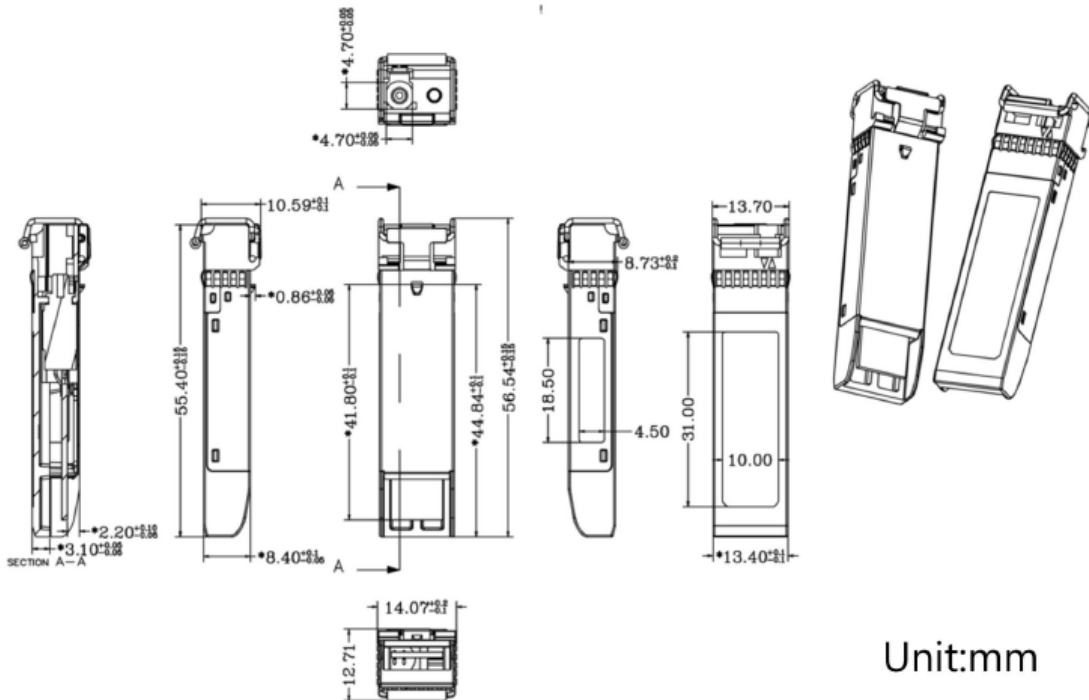

About ProLabs

Our extensive experience comes as standard. For over 20 years ProLabs has delivered optical connectivity solutions that give our customers freedom and choice through our ability to provide seamless interoperability. At the heart of our company is the ability to provide state-of-the-art optical transport and connectivity solutions that are compatible with more than 100 optical switching and transport platforms.

A Complete Portfolio of Network Solutions

ProLabs is focused on innovations in optical transport and connectivity. The combination of our knowledge of optics and networking equipment enables ProLabs to be your single source for optical transport and connectivity solutions from 100Mb to 1.6T while providing innovative solutions that increase network efficiency. We provide the optical connectivity expertise that is compatible with and enhances your switching and transport equipment.

The Trusted Partner

Customer service is our number one value. ProLabs has invested in people, labs and manufacturing capacity to ensure compatible products, and immediate answers to your questions. With Engineering and Manufacturing offices in the U.K. and U.S. augmented by field offices throughout the U.S., U.K. and Asia, ProLabs is able to be our customers best advocate 24 hours a day.



Contact Information

ProLabs US

Email: sales@prolabs.com

Telephone: 952-852-0252

ProLabs UK

Email: salessupport@prolabs.com

Telephone: +44 1285 719 600