

SFP-10GBASE-SR-A-C

MSA and TAA 10GBase-SR SFP+ Transceiver (MMF, 850nm, 300m, LC, DOM, CDR)

Features:

- Operating data rate up to 11.3Gbps
- 850nm VCSEL Transmitter
- Distance up to 300m at 50/125 um MMF
- Duplex LC Connector Interface, Hot-Pluggable
- Built-in dual CDR
- Compliant with MSA SFP+ Specification SFF-8431
- Compliant with IEEE 802.3ae 10GBASE-SR/SW
- Power Dissipation: 1.5W
- Dispersion Tolerance up to 40ps/nm over G.651
- Operating Temperature: 0 to 70 Celsius
- RoHS Compliant and Lead-Free



Applications:

- 10GBase Ethernet

Product Description

This MSA compliant SFP+ transceiver provides 10GBase-SR throughput up to 300m over multi-mode fiber (MMF) using a wavelength of 850nm via an LC connector. It has been programmed, uniquely serialized, and tested for data-traffic and application to ensure that it will initialize and perform identically. All of our transceivers comply with Multi-Source Agreement (MSA) standards to provide seamless network integration. Additional product features include Digital Optical Monitoring (DOM) support which allows access to real-time operating parameters. This transceiver is Trade Agreements Act (TAA) compliant. We stand behind the quality of our products and proudly offer a limited lifetime warranty.

ProLabs' transceivers are RoHS compliant and lead-free.

TAA refers to the Trade Agreements Act (19 U.S.C. & 2501-2581), which is intended to foster fair and open international trade. TAA requires that the U.S. Government may acquire only "U.S.-made or designated country end products.")



Absolute Maximum Ratings

Parameter	Symbol	Min.	Typ.	Max.	Unit	Notes
Storage Temperature	Tstg	-40		85	°C	
Operating Case Temperature	Tc	0		70	°C	
Relative Humidity	RH	5		95	%	
Supply Voltage	Vcc	-0.5		3.6	V	
Input Voltage	VIN	-0.5		Vcc	V	
Output Current	Io			20	mA	
Baud Rate			10.3125 9.95		Gbps	
Data Rate			10.3125		Gbps	

Electrical Characteristics

Parameter	Symbol	Min.	Typ.	Max.	Unit	Notes
Power Supply Voltage	Vcc	3.15	3.3	3.45	V	
Module Supply Current	Icc			435	mA	
Surge Current						
50/125µm MMF			300		m	
Transmitter						
Differential CML Input	VIN	120		850	Ω	AC coupled inputs
Differential Input Impedance	ZIN	85	100	115	mVp-p	RIN > 100kΩ @ DC
Tx_Disable Input Voltage - High		2		Vcc+0.3	V	
Tx_Disable Input Voltage - Low		0		0.8	V	
Tx_Fault Output Voltage - High		2		Vcc+0.3	V	1
Tx_Fault Output Voltage - Low		0		0.8	V	2
Receiver						
Differential CML Output	VOUT	100		850	mVp-p	AC coupled outputs
Differential Output Impedance	ZOUT	85	100	115	Ω	
Rx_LOS Output Voltage - High		2		Vcc+0.3	V	1
Rx_LOS Output Voltage - Low		0		0.8	V	2
MOD_DEF(2.0)	VOH	2.5			V	With serial ID
	VOL	0		0.5	V	

Notes:

1. Io = 400µA. Host_Vcc.
2. Io = 4.0mA.

Optical Characteristics

Parameter	Symbol	Min.	Typ.	Max.	Unit	Notes
Transmitter						
Center Wavelength	λ_C	840	850	860	nm	
Spectral Width (RMS)	$\Delta\lambda$			0.45	nm	
Average Output Power	POUT	-6		-1	dBm	
Extinction Ratio	ER	3.0	5.0		dB	
Transmitter Dispersion Penalty	TDP			3.9	dB	
Input Differential Impedance	ZIN	90	100	110	Ω	
Tx_Disable Assert Time	t_off			10	us	
Tx_Disable Negate Time	t_on			1	ms	
Tx_Disable Time to Start Reset	t_reset	10			us	
Time to Initialize (Includes Reset of Tx_Fault)	t_init			300	ms	
Tx_Fault from Fault to Assertion	t_fault			100	us	
Total Jitter	TJ			0.28	UI(p-p)	
Data-Dependent Jitter	DDJ			0.1	UI(p-p)	
Uncorrelated Jitter	UJ			0.023	RMS	
Output Optical Eye		IEEE 802.3-2005 Compliant				
Receiver						
Center Wavelength	λ_C	840	850	860	nm	
Receiver Sensitivity	Pmin			-11.1	dBm	1
Output Differential Impedance	RIN	90	100	110	Ω	
Receiver Overload	Pmax	-1			dBm	
Optical Return Loss	ORL			-12	dB	
LOS De-Assert	LOSD			-12.5	dBm	
LOS Assert	LOSA	-25			dBm	
LOS Hysteresis		0.5			dB	
LOS	High		2.0		Vcc+0.3	V
	Low		0		0.8	V

Notes:

1. Measured with a PRBS $2^{31}-1$ test pattern @10.3125Gbps and $BER \leq 10^{-12}$.

Pin Descriptions

Pin	Symbol	Name/Description	Plug Seq.	Notes
1	VeeT	Transmitter Ground.	1	
2	Tx_Fault	Transmitter Fault Indication.	3	1
3	Tx_Disable	Transmitter Disable. Module disables on “high” or “open.”	3	2
4	SDA	Module Definition 2. Data Line for Serial ID.	3	
5	SCL	Module Definition 1. Clock Line for Serial ID.	3	
6	MOD_ABS	Module Definition 0.	3	3
7	RS0	Rx Rate Select. LVTTTL. Rate Select 0 optionally controls the SFP+ module receiver. This pin is pulled low to the VeeT with a >30K resistor.	3	
8	LOS	Loss of Signal.	3	4
9	RS1	Tx Rate Select. LVTTTL. Rate Select 1 optionally controls the SFP+ module transmitter. This pin is pulled low to the VeeT with a >30K resistor.	1	
10	VeeR	Receiver Ground.	1	5
11	VeeR	Receiver Ground.	1	5
12	RD-	Inverse Received Data Out.	3	6
13	RD+	Received Data Out.	3	6
14	VeeR	Receiver Ground.	1	5
15	VccR	3.3V ± 5% Receiver Power.	2	7
16	VccT	3.3V ± 5% Transmitter Power.	2	7
17	VeeT	Transmitter Ground.	1	5
18	TD+	Transmitter Data In.	3	8
19	TD-	Inverse Transmitter Data In.	3	8
20	VeeT	Transmitter Ground.	1	5

Notes:

- Tx_Fault is an open collector/drain output that should be pulled up with a 4.7kΩ to 10kΩ resistor on the host board. Pull-up voltage is between 2.0V and $V_{ccT}/R+0.3V$. When high, output indicates a laser fault of some kind. Low indicates normal operation. In the low state, the output will be pulled to <0.8V.
- Tx_Disable is an input that is used to shut down the transmitter optical output. It is pulled up within the module with a 4.7kΩ to 10kΩ resistor. Its states are:
 - Low (0V to 0.8V): Transmitter On
 - (>0.8V and <2V): Undefined
 - High (2.0V to 3.465V): Transmitter Disabled
 - Open: Transmitter Disabled.
- Modulation absent. Connected to the VeeT or VeeR in the module.
- LOS (Loss of Signal) is an open collector/drain output that should be pulled up with a 4.7kΩ to 10kΩ resistor. Pull-up voltage is between 2.0V and $V_{ccT}/R+0.3V$. When high, this output indicates that the received optical power is below the worst-case receiver sensitivity (as defined by the standard in use).

Low indicates normal operation. In the low state, the output will be pulled to <0.8V.

5. VeeR and VeeT may be internally connected within the SFP+ module.
6. RD-/+. These are the differential receiver outputs. They are AC-coupled, 100Ω differential lines which should be terminated with 100Ω (differential) at the user SERDES. The AC coupling is done inside the module and is thus not required on the host board. The voltage swing on these lines will be between 400mV and 2000mV differential (50mV and 425mV single-ended) when properly terminated.
7. VccR and VccT are the receiver and transmitter power supplies. They are defined as 3.3V ±5% at the SFP+ connector pin. Maximum supply current is 300mA. Inductors with DC resistance of less than 1Ω should be used in order to maintain the required voltage at the SFP+ input pin with 3.3V supply voltage. When the recommended supply-filtering network is used, hot-plugging of the SFP+ transceiver module will result in an in-rush current of no more than 30mA greater than the steady state value. VccR and VccT may be internally connected within the SFP+ transceiver module.
8. TD-/+. These are the differential transmitter inputs. They are AC-coupled, differential lines with 100Ω differential termination inside the module. The AC coupling is done inside the module and is thus not required on the host board. The inputs will accept differential swings of 120mV to 850mV (60mV to 425mV single-ended), though it is recommended that the values are between 120mV and 850mV differential (60mV and 425mV single-ended) for the best EMI performance.

Electrical Pad Layout

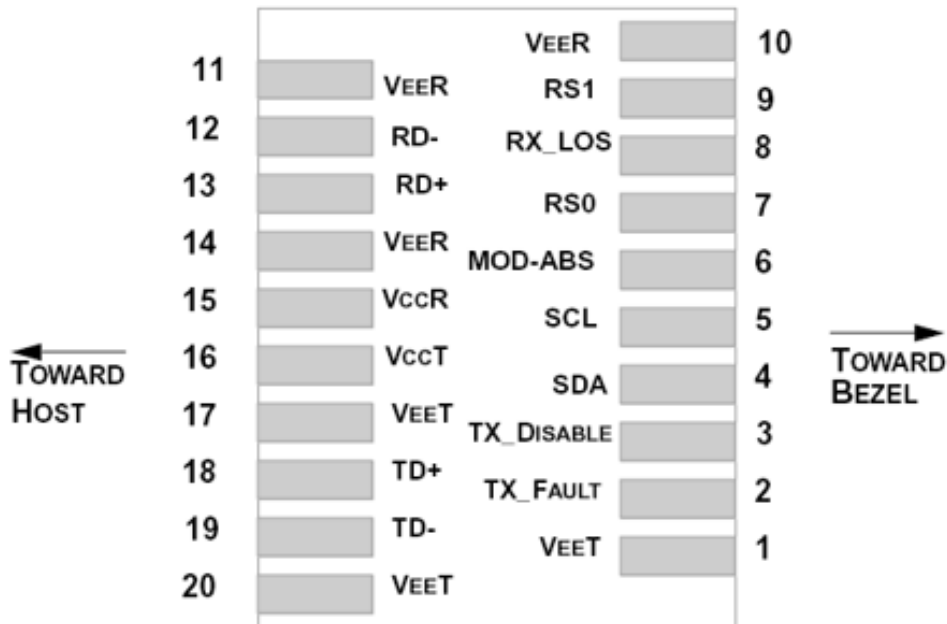



Recommended Circuit Schematic

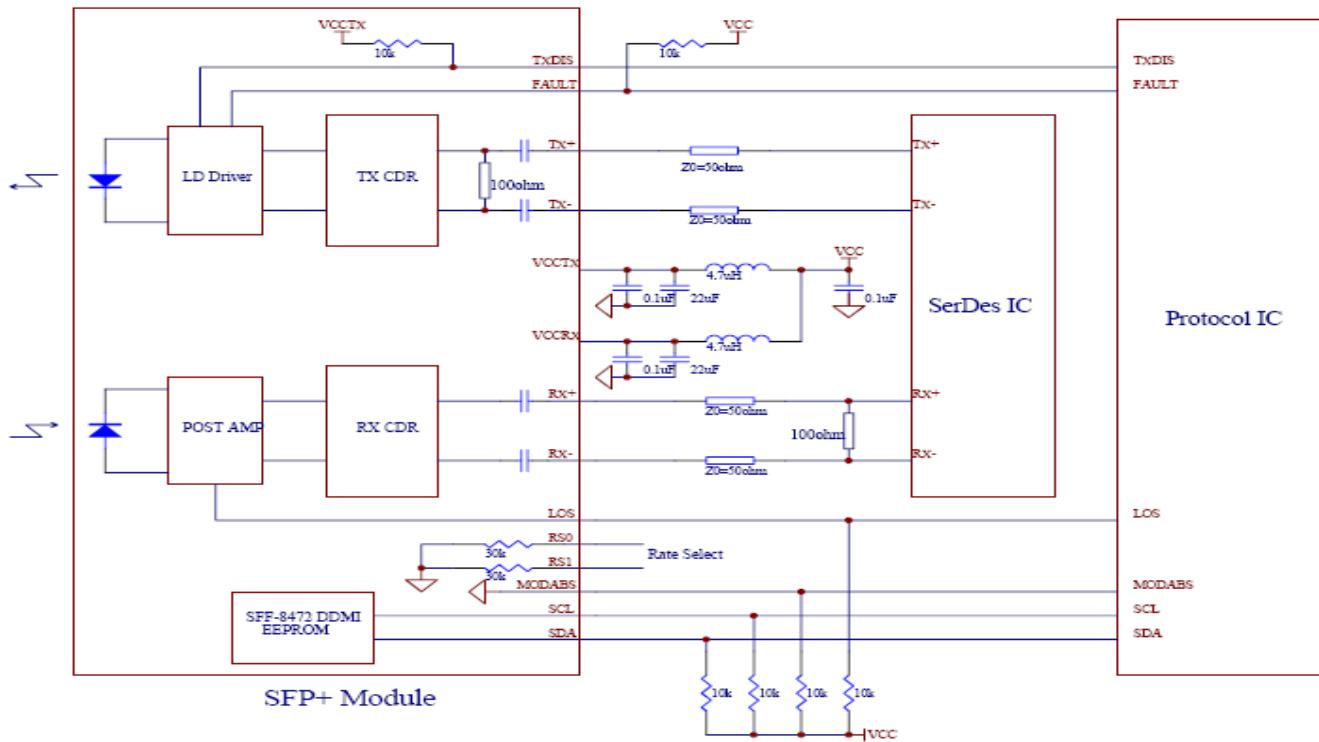

Mechanical Specifications

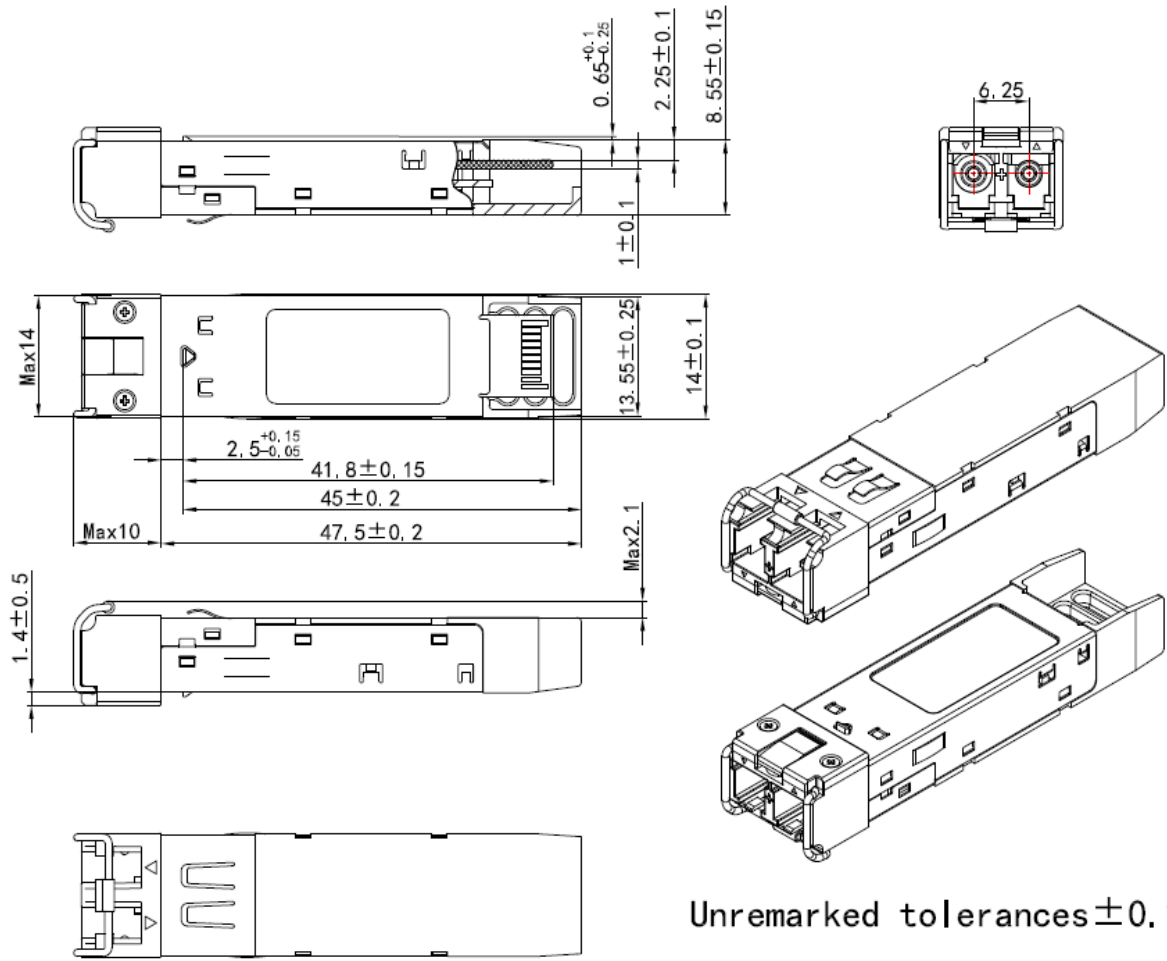

Unremarked tolerances ± 0.2 mm

About ProLabs

Our extensive experience comes as standard. For over 20 years ProLabs has delivered optical connectivity solutions that give our customers freedom and choice through our ability to provide seamless interoperability. At the heart of our company is the ability to provide state-of-the-art optical transport and connectivity solutions that are compatible with more than 100 optical switching and transport platforms.

A Complete Portfolio of Network Solutions

ProLabs is focused on innovations in optical transport and connectivity. The combination of our knowledge of optics and networking equipment enables ProLabs to be your single source for optical transport and connectivity solutions from 100Mb to 1.6T while providing innovative solutions that increase network efficiency. We provide the optical connectivity expertise that is compatible with and enhances your switching and transport equipment.

The Trusted Partner

Customer service is our number one value. ProLabs has invested in people, labs and manufacturing capacity to ensure compatible products, and immediate answers to your questions. With Engineering and Manufacturing offices in the U.K. and U.S. augmented by field offices throughout the U.S., U.K. and Asia, ProLabs is able to be our customers best advocate 24 hours a day.



Contact Information

ProLabs US

Email: sales@prolabs.com

Telephone: 952-852-0252

ProLabs UK

Email: salessupport@prolabs.com

Telephone: +44 1285 719 600