

## **DSFP-100GB-AOC7M-C**

MSA and TAA 100GBase-AOC DSFP Active Optical Cable (850nm, MMF, 7m, CMIS 4.0)

### **Features:**

- Compliant with IEEE 802.3-2018
- 2x26.5625GBD PAM4 Active Optical Cable
- Compliant to the DSFP MSA Transceiver Specifications
- Low Power Dissipation: 2.5W Per Cable End
- Hot-Pluggable
- Operating Temperature: 0 to 70 Celsius
- RoHS Compliant and Lead-Free



### **Applications:**

- 100GBase Ethernet

### **Product Description**

This MSA compliant DSFP to DSFP transceiver provides 100GBase-AOC throughput up to over Fiber using a wavelength of 850nm via a DSFP connector. All of our transceivers are built to comply with Multi-Source Agreement (MSA) standards and are uniquely serialized and tested for data-traffic and application to ensure seamless network integration. This transceiver is Trade Agreements Act (TAA) compliant. We stand behind the quality of our products and proudly offer a limited lifetime warranty.

ProLabs' transceivers are RoHS compliant and lead-free.

TAA refers to the Trade Agreements Act (19 U.S.C. & 2501-2581), which is intended to foster fair and open international trade. TAA requires that the U.S. Government may acquire only "U.S.-made or designated country end products.")



### Absolute Maximum Ratings

Parameter	Symbol	Min.	Typ.	Max.	Unit	Notes
Supply Voltage	V <sub>CC</sub>	-0.5		3.6	V	
Storage Temperature	T <sub>stg</sub>	-40		85	°C	
Operating Case Temperature	T <sub>c</sub>	0		70	°C	
Relative Humidity	RH	15		85	%	
Data Rate	DR		26.5625		GBd	±100ppm
Bit Error Rate	BER				1E <sup>-8</sup>	

### Electrical Characteristics

Parameter	Symbol	Min.	Typ.	Max.	Unit	Notes
Power Dissipation	P <sub>DISS</sub>			2.5	W	
Module Supply Voltage	V <sub>CC</sub>	3.13	3.3	3.47	V	
Supply Current	I <sub>CC</sub>			796	mA	
<b>Receiver</b>						
AC Common-Mode Input Voltage				17.5	mV	RMS
Differential Peak-to-Peak Input Voltage				900	mV	
FEC Symbol Error				5		

### Optical Characteristics

Parameter	Symbol	Min.	Typ.	Max.	Unit	Notes
<b>Transmitter</b>						
Center Wavelength	λ <sub>C</sub>	840		860	nm	
Optical Power Output	P <sub>O</sub>	-6.5		4	dBm	
Spectral Width	Δλ <sub>20</sub>			0.6	nm	
Extinction Ratio	ER	3			dB	
<b>Receiver</b>						
Near-End ESMW	EW		0.265		UI	
Near-End Eye Height	EH	70		mV		
Far-End ESMW			0.2			
Far-End Eye Height		30		UI		
Far-End Pre-Cursor ISI Ratio		-4.5		3.5	%	

## Pin Descriptions

Pin	Logic	Symbol	Sequence	Name/Description	Notes
1	CML-I	TD2-	3	Transmitter Inverted Data Input Lane 2.	
2	CML-I	TD2+	3	Transmitter Non-Inverted Data Input Lane 2.	
3		GND	1	Module Ground.	
4	LVTTL-I/O	SDA	3	2-Wire Serial Interface Data.	
5	LVTTL-I/O	SCL	3	2-Wire Serial Interface Clock.	
6	Multi-Level-I/O	LPWn/PRSn	3	Low-Power Mode/Module Present (MOD_ABS).	
7		GND	1	Module Ground.	
8	CML-O	RD2+	3	Receiver Non-Inverted Data Output Lane 2.	
9	CML-O	RD2-	3	Receiver Inverted Data Output Lane 2.	
10		GND	1	Module Ground.	
11		GND	1	Module Ground.	
12	CML-O	RD1-	3	Receiver Inverted Data Output Lane 1.	
13	CML-O	RD1+	3	Receiver Non-Inverted Data Output Lane 1.	
14		GND	1	Module Ground.	
15		Vcc	2	Module +3.3V Power Supply.	
16		Vcc	2	Module +3.3V Power Supply.	
17		GND	1	Module Ground.	
18		TD1+	3	Transmitter Non-Inverted Data Input Lane 1.	
19		TD1-	3	Transmitter Inverted Data Input Lane 1.	
20		GND	1	Module Ground.	
21	Multi-Level-I/O	INT/RSTn	3	Dual-Function Module Interrupt and Reset Pin.	
22		GND	1	Module Ground.	

## Electrical Pin-Out Details

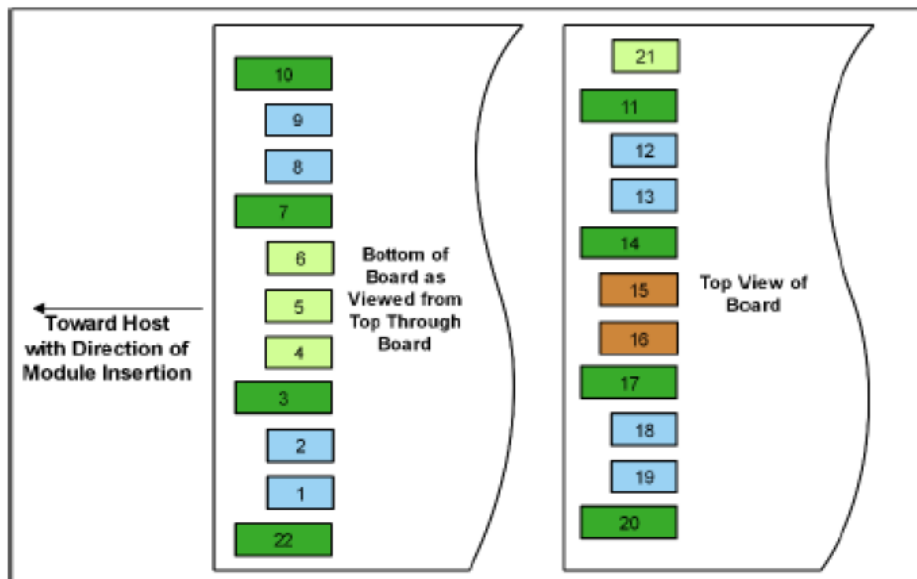

### Block Diagram

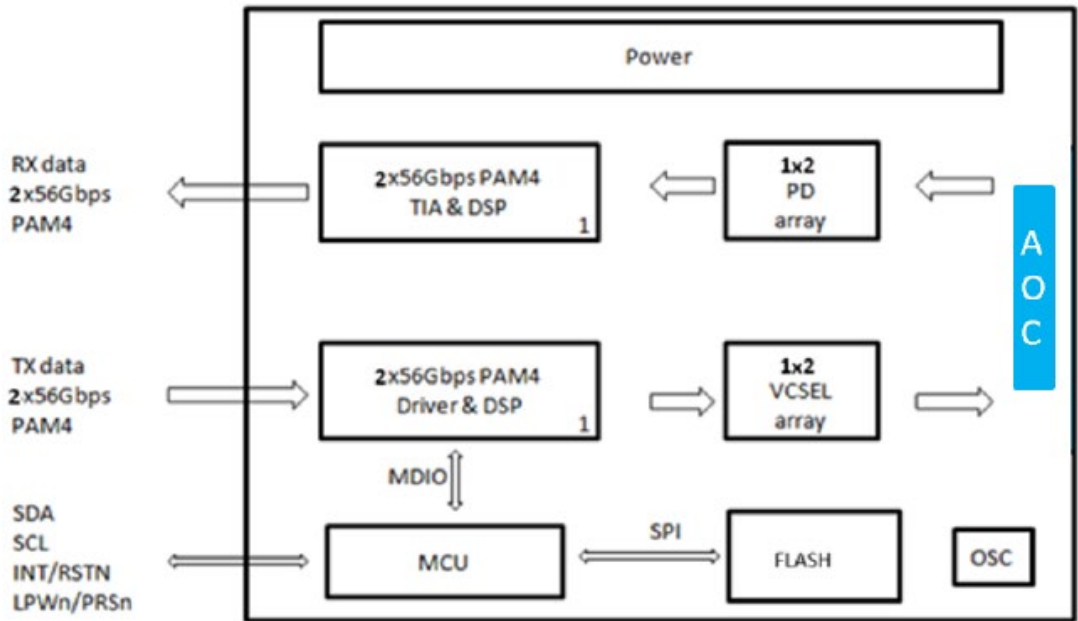

### Recommended Interface Circuit

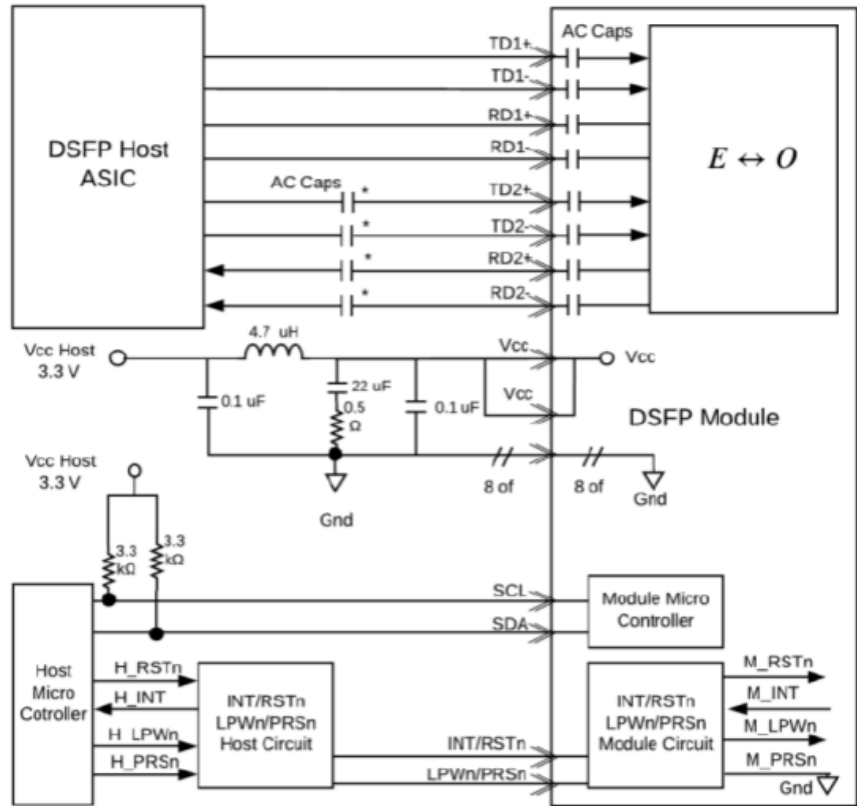

**Notes:** Host AC caps allow SFP+ backward compatibility. If SFP+ modules will never be plugged in, the host AC caps can be omitted.

# Mechanical Specifications

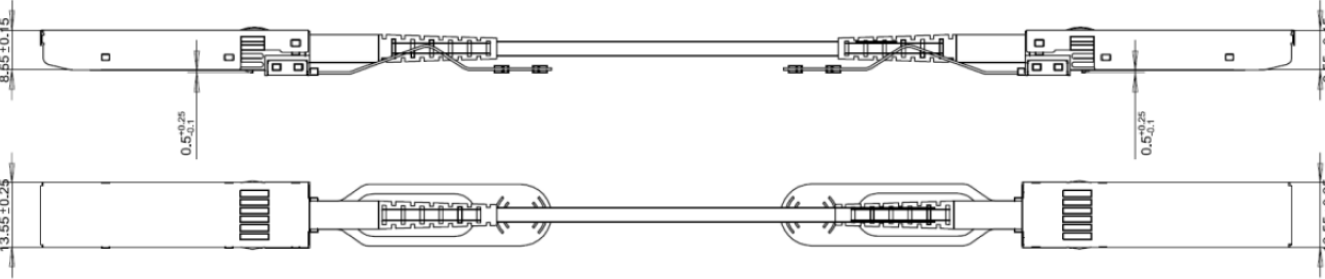
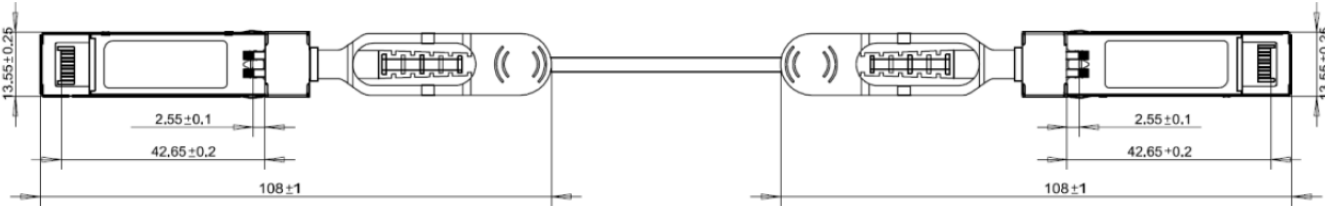

## About ProLabs

Our extensive experience comes as standard. For over 20 years ProLabs has delivered optical connectivity solutions that give our customers freedom and choice through our ability to provide seamless interoperability. At the heart of our company is the ability to provide state-of-the-art optical transport and connectivity solutions that are compatible with more than 100 optical switching and transport platforms.

## A Complete Portfolio of Network Solutions

ProLabs is focused on innovations in optical transport and connectivity. The combination of our knowledge of optics and networking equipment enables ProLabs to be your single source for optical transport and connectivity solutions from 100Mb to 1.6T while providing innovative solutions that increase network efficiency. We provide the optical connectivity expertise that is compatible with and enhances your switching and transport equipment.

## The Trusted Partner

Customer service is our number one value. ProLabs has invested in people, labs and manufacturing capacity to ensure compatible products, and immediate answers to your questions. With Engineering and Manufacturing offices in the U.K. and U.S. augmented by field offices throughout the U.S., U.K. and Asia, ProLabs is able to be our customers best advocate 24 hours a day.



## Contact Information

ProLabs US

Email: [sales@prolabs.com](mailto:sales@prolabs.com)

Telephone: 952-852-0252

ProLabs UK

Email: [salessupport@prolabs.com](mailto:salessupport@prolabs.com)

Telephone: +44 1285 719 600