

SFP-25GB-LRL-I-C

MSA and TAA 25GBase-LRL SFP28 Transceiver Capable (SMF, 1310nm, 2km, LC, DOM, -40 to 85C)

Features:

- Up to 25.78Gbps Bi-Directional Data Links
- SFP28 MSA Package with Duplex LC Connectors
- Up to 2km on 9/125µm SMF
- Single 3.3V Power Supply
- Class 1 Laser Safety Certified
- Built-In Dual CDR with Shut-Off Control
- Uncooled 1310nm DFB Laser
- Power Consumption: less than 1.2W
- Operating Temperature: -40 to 85 Celsius
- RoHS Compliant and Lead-Free



Applications:

- 25GBase Ethernet
- Access and Enterprise

Product Description

This MSA compliant SFP28 transceiver provides 25GBase-LRL throughput up to 2km over single-mode fiber (SMF) using a wavelength of 1310nm via an LC connector. It is capable of withstanding rugged environments and can operate at temperatures between -40 and 85C. All of our transceivers are built to comply with Multi-Source Agreement (MSA) standards and are uniquely serialized and tested for data-traffic and application to ensure seamless network integration. Additional product features include Digital Optical Monitoring (DOM) support which allows access to real-time operating parameters. This transceiver is Trade Agreements Act (TAA) compliant. We stand behind the quality of our products and proudly offer a limited lifetime warranty.

ProLabs' transceivers are RoHS compliant and lead-free.

TAA refers to the Trade Agreements Act (19 U.S.C. & 2501-2581), which is intended to foster fair and open international trade. TAA requires that the U.S. Government may acquire only "U.S.-made or designated country end products.")



Absolute Maximum Ratings

Parameter	Symbol	Min.	Typ.	Max.	Unit	Notes
Supply Voltage	Vcc	-0.5		4.0	V	
Storage Temperature	Tstg	-40		85	°C	
Operating Case Temperature	Tc	-40	25	85	°C	
Relative Humidity	RH	5		95	%	
Maximum Receive Power				2	dBm	
Data Rate		9.8304		25.78125	Gbps	

Electrical Characteristics

Parameter	Symbol	Min.	Typ.	Max.	Unit	Notes
Supply Voltage	Vcc	3.135	3.3	3.465	V	
Module Supply Current	Icc			360	mA	
Power Dissipation	P _{DISS}			1200	mW	
Transmitter						
Input Differential Impedance	ZIN		100		Ω	
Differential Data Input Swing	VIN,pp	180		700	mVp-p	
Tx_Fault	Transmitter Fault	VOH	2.0	Host_Vcc	V	
	Normal Operation	VOL	0	0.8	V	
Tx_Disable	Transmitter Disable	VIH	2.0	Host_Vcc	V	
	Transmitter Enable	VIL	0	0.8	V	
Receiver						
Output Differential Impedance	ZO		100		Ω	
Differential Data Output Swing	VOUT,pp	300		850	mVp-p	1
Data Output Rise/Fall Time	Tr/Tf	15			ps	2
Rx_LOS	Loss of Signal (LOS)	VOH	2.0	Host_Vcc	V	3
	Normal Operation	VOL	0	0.8	V	3

Notes:

1. Internally AC coupled but requires an external 100Ω differential load termination.
2. 20-80%.
3. LOS is an open collector output. Should be pulled up with 4.7kΩ on the host board.

Optical Characteristics

Parameter	Symbol	Min.	Typ.	Max.	Unit	Notes
Transmitter						
Launch Optical Power	Pavg	-5		2	dBm	1
Optical Modulation Amplitude	POMA	-7		2	dBm	
Extinction Ratio	ER	3.5			dB	
Center Wavelength Range	λ_C	1295	1310	1325	nm	
Transmitter Dispersion Penalty	TDP			1.0	dB	
SMSR		30			dB	
Spectral Width	$\Delta\lambda$			1	nm	2
Optical Return Loss Tolerance	ORLT			20	dB	
Transmitter Reflectance				-26	dB	
POUT @Tx_Disable Asserted	Poff			-30	dBm	
Eye Test : {X1, X2, X3, Y1, Y2, Y3}		5			%	3
Receiver						
Center Wavelength	λ_C	1295	1310	1325	nm	
Receiver OMA Sensitivity	RxSENS			-11	dBm	4
Receiver Overload (Pavg)	POL	2			dBm	
Receiver Reflectance				-26	dB	
LOS De-Assert	LOSD			-15	dBm	
LOS Assert	LOSA	-30			dBm	
LOS Hysteresis		0.5		5	dB	

Notes:

1. Class 1 Laser Safety per FDA/CDRH and EN (IEC) 60825 regulations.
2. 20dB spectral width.
3. Test condition: {0.31, 0.4, 0.45, 0.34, 0.38, 0.4}. Hit count = $5E^{-5}$.
4. Measured with PRBS $2^{31}-1$ at 5×10^{-5} BER.

Pin Descriptions

Pin	Symbol	Name/Description	Notes
1	VeeT	Transmitter Ground.	1
2	Tx_Fault	Transmitter Fault (LVTTTL-O). "High" indicates a fault condition.	2
3	Tx_Disable	Transmitter Disable (LVTTTL-I). "High" or "open" disables the transmitter.	3
4	SDA	2-Wire Serial Interface Data (LVCMOS-I/O, MOD_DEF2).	4
5	SCL	2-Wire Serial Interface Clock (LVCMOS-I/O, MOD_DEF1).	4
6	MOD_ABS	Module Absent (Output). Connected to the VeeT or VeeR in the module.	5
7	RS0	Hardware Tx Rate Select Pin.	6
8	Rx_LOS	Receiver Loss of Signal (LVTTTL-O).	2
9	RS1	Hardware Rx Rate Select Pin.	6
10	VeeR	Receiver Ground.	1
11	VeeR	Receiver Ground.	1
12	RD-	Inverse Received Data Out (CML-O).	
13	RD+	Received Data Out (CML-O).	
14	VeeR	Receiver Ground.	
15	VccR	+3.3V Receiver Power.	
16	VccT	+3.3V Transmitter Power.	
17	VeeT	Transmitter Ground.	1
18	TD+	Transmitter Data In (CML-I).	
19	TD-	Inverse Transmitter Data In (CML-I).	
20	VeeT	Transmitter Ground.	1

Notes:

1. The module signal grounds are isolated from the module case.
2. This is an open collector/drain output that, on the host board, requires a 4.7k Ω to 10k Ω pull-up resistor to the Host_Vcc.
3. This input is internally biased "high" with a 4.7k Ω to 10k Ω pull-up resistor to the VccT.
4. 2-Wire Serial Interface Clock and Data lines require an external pull-up resistor dependent on the capacitance load.
5. This is a ground return that, on the host board, requires a 4.7k Ω to 10k Ω pull-up resistor to the Host_Vcc.
6. Rate Select can also be set through the 2-wire bus in accordance with SFF-8472 v. 12.1. Rx Rate Select is set at Bit 3, Byte 110, and Address A2h. Tx Rate Select is set at Bit 3, Byte 118, and Address A2h.
Note: Writing a "1" selects the maximum bandwidth operation. Rate Select is the logic OR of the input state of Rate Select Pin and 2-wire bus.

Electrical Pin-Out Details

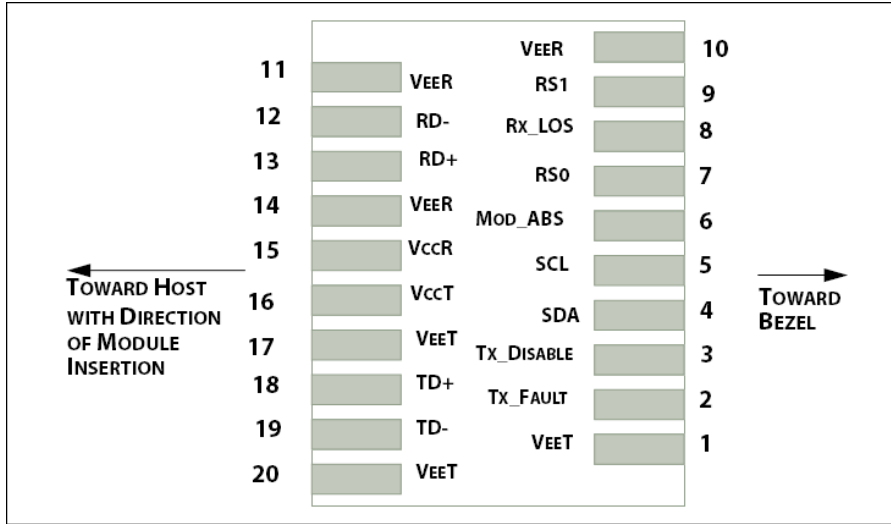

Recommended Host Board Power Supply Filter Network

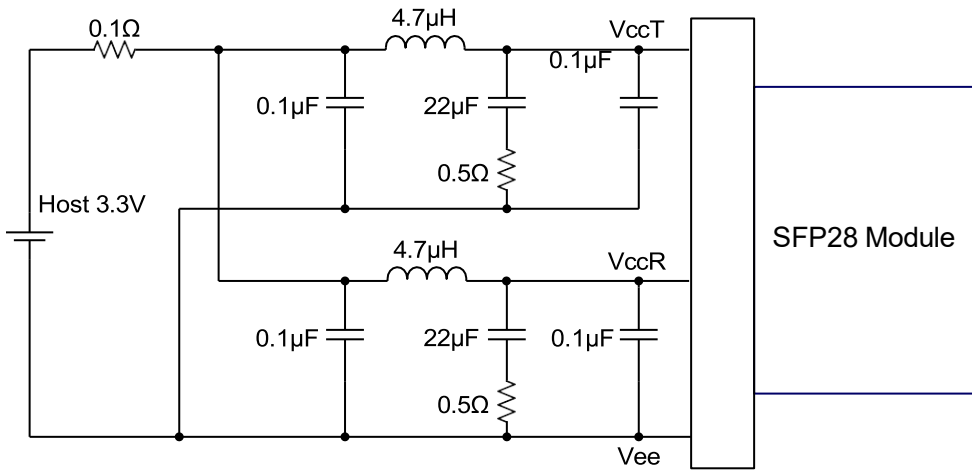

Recommended Application Interface Block Diagram

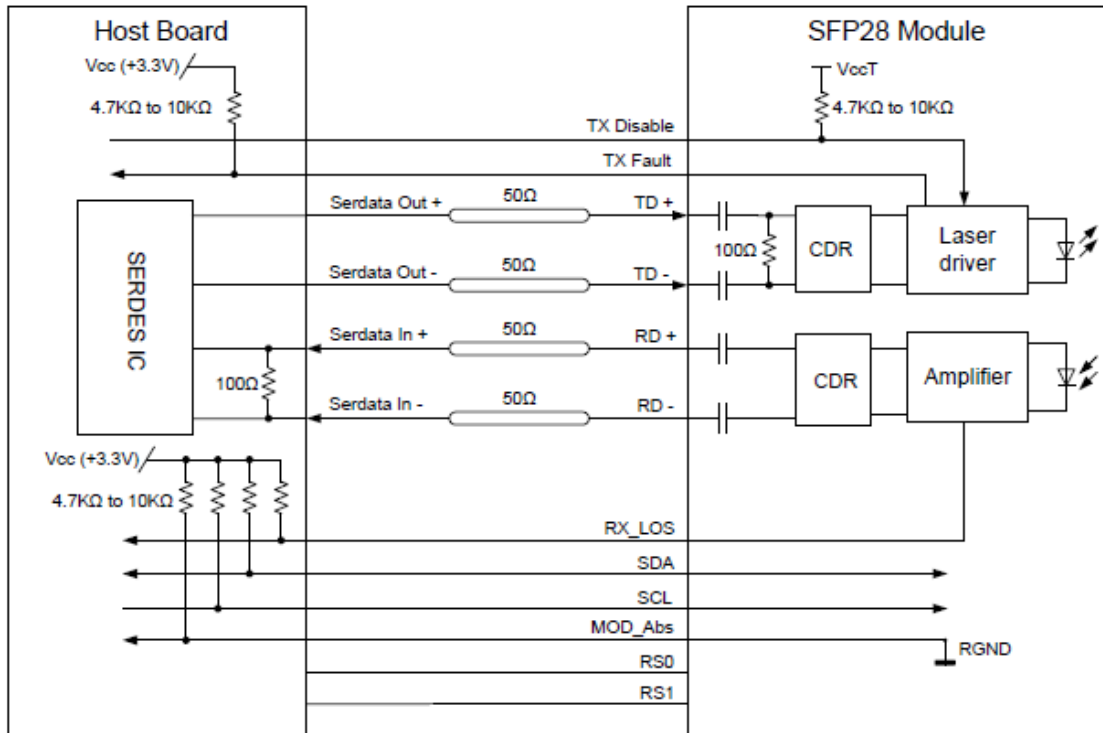

Mechanical Specifications

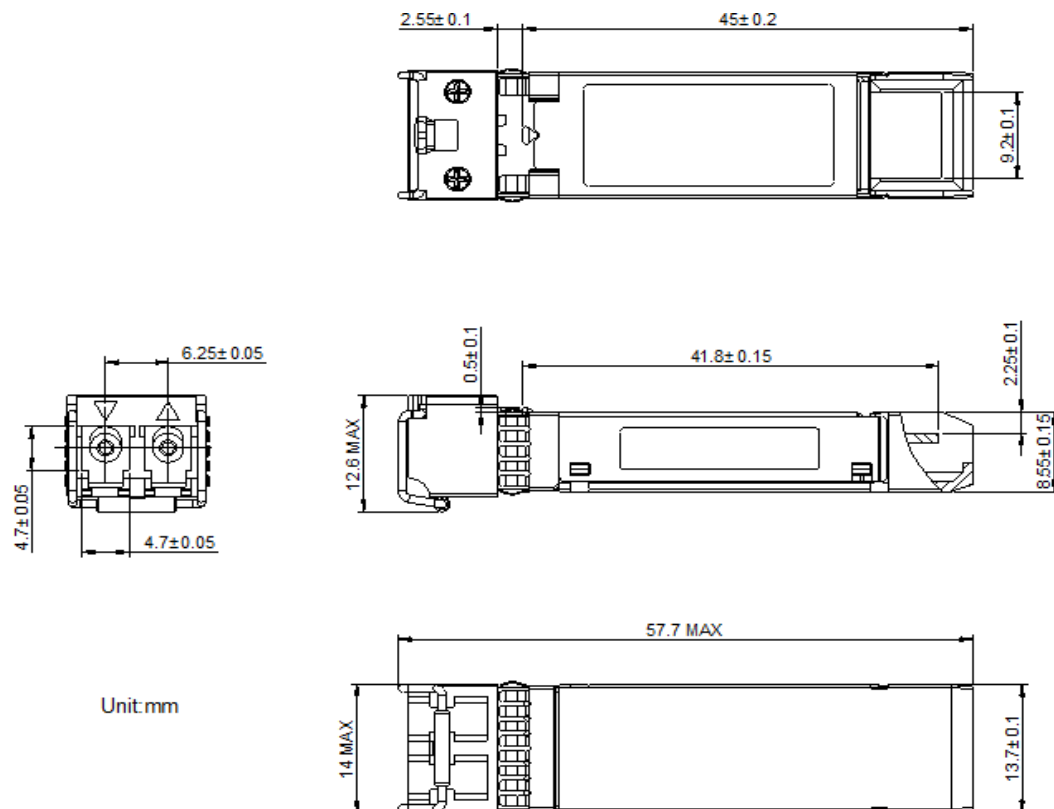

About ProLabs

Our extensive experience comes as standard. For over 20 years ProLabs has delivered optical connectivity solutions that give our customers freedom and choice through our ability to provide seamless interoperability. At the heart of our company is the ability to provide state-of-the-art optical transport and connectivity solutions that are compatible with more than 100 optical switching and transport platforms.

A Complete Portfolio of Network Solutions

ProLabs is focused on innovations in optical transport and connectivity. The combination of our knowledge of optics and networking equipment enables ProLabs to be your single source for optical transport and connectivity solutions from 100Mb to 1.6T while providing innovative solutions that increase network efficiency. We provide the optical connectivity expertise that is compatible with and enhances your switching and transport equipment.

The Trusted Partner

Customer service is our number one value. ProLabs has invested in people, labs and manufacturing capacity to ensure compatible products, and immediate answers to your questions. With Engineering and Manufacturing offices in the U.K. and U.S. augmented by field offices throughout the U.S., U.K. and Asia, ProLabs is able to be our customers best advocate 24 hours a day.



Contact Information

ProLabs US

Email: sales@prolabs.com

Telephone: 952-852-0252

ProLabs UK

Email: salessupport@prolabs.com

Telephone: +44 1285 719 600