

QSFP56-200GB-C4-SR4-C

MSA and TAA 200GBase-SR4 QSFP56 Transceiver (MMF, 850nm, 100m, UPC MPO, DOM, CMIS 4.0)

Features:

- 4-Channel Full-Duplex Transceiver
- Hot-Pluggable QSFP56 Form Factor
- Supports 212.5Gbps Aggregate Bit Rate
- Maximum Link Length of 100M on OM4 Multi-Mode Fiber
- 200GAUI-4 C2M Electrical Interface (4x50Gbps PAM4 Retimed)
- Power Dissipation Below 4.5W
- Single 3.3V Power Supply
- MPO-12 Connector
- Operating Temperature: 0 to 70 Celsius
- RoHS Compliant and Lead-Free

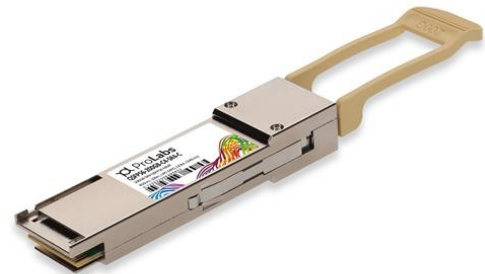

Applications:

- 200GBase Ethernet

Product Description

This MSA compliant QSFP56 transceiver provides 200GBase-SR4 throughput up to 100m over multi-mode fiber (MMF) using a wavelength of 850nm via an MPO-12 connector. All of our transceivers are built to comply with Multi-Source Agreement (MSA) standards and are uniquely serialized and tested for data-traffic and application to ensure seamless network integration. Additional product features include Digital Optical Monitoring (DOM) support which allows access to real-time operating parameters. This transceiver is Trade Agreements Act (TAA) compliant. We stand behind the quality of our products and proudly offer a limited lifetime warranty.

ProLabs' transceivers are RoHS compliant and lead-free.

TAA refers to the Trade Agreements Act (19 U.S.C. & 2501-2581), which is intended to foster fair and open international trade. TAA requires that the U.S. Government may acquire only "U.S.-made or designated country end products."



Absolute Maximum Ratings

Parameter	Symbol	Min.	Typ.	Max.	Unit	Notes
Maximum Supply Voltage	V _{cc}	-0.5		3.6	V	
Storage Temperature	T _{stg}	-40		85	°C	
Relative Humidity	RH	15		85	%	1
Operating Case Temperature	T _c	0		70	°C	2
Receiver Damage Threshold, per Lane	P _{Rdmg}	5			dBm	
Bit Rate (all wavelengths combined)	BR			212.5	Gbps	3
Bit Error Ratio	BER			2.4E-4		4
Signaling Rate per Lane		26.5625 ± 100ppm				
Modulation Format		PAM4				
Maximum Supported Distances	OM3 MMF	L _{max1}		70	m	
	OM4 MMF	L _{max2}		100		

Notes:

1. Non-condensing.
2. 48-Hour excursion ns, maximum.
3. Supports 200GBASE-SR4 per IEEE P802.3cd.
4. The typical BER is better than 1E-6 when Measured with a transmitter to produce SECQ up to 3dB.

Electrical Characteristics

Parameter	Symbol	Min.	Typ.	Max.	Unit	Notes
Module Supply Voltage	V _{cc}	3.135	3.3	3.465	V	
Module Supply Current	I _{cc}			1.595	A	
Module Power Dissipation	P			4.5	W	1
Transmitter						
Differential Peak-to-Peak Input Voltage Tolerance	V _{IN,pp}	900			mV	2
Differential Termination Mismatch				10	%	
Single-ended voltage tolerance range		-0.4		3.3	V	3
DC common mode voltage		-350		2850	mV	
Differential input return loss		Per equation (83E-5) IEEE802.3-2018			dB	
Differential to common mode input return loss		Per equation (83E-6) IEEE802.3-2018			dB	
Module stress input test		Per 120E.3.4.1 IEEE802.3-2018				4
Receiver						
AC common-mode output voltage (RMS)				17.5	mV	
Differential peak-to-peak output voltage				900	mV	
Near-end ESMW (Eye symmetry mask width)		0.265			UI	

Near-end Eye height, differential (min)		70			mV	
Far-end ESMW (Eye symmetry mask width)		0.2			UI	
Far-end Eye height, differential (min)		30			mV	
Far-end pre-cursor ISI ratio		-4.5		2.5	%	
Differential termination mismatch				10	%	
Transition time (min, 20% to 80%)		9.5			ps	
DC common mode voltage		-350		2850	mV	4
Differential output return loss		Per equation 83E-2 IEEE802.3-2018				
Common to differential mode conversion return loss		Per equation 83E-3 IEEE802.3-2018				

Notes:

1. Maximum total power value is specified across the full temperature and voltage range.
2. With the exception to 120E.3.1.2 that the pattern is PRBS31Q or scrambled idle.
3. Meets specified BER.
4. DC common mode voltage generated by the host. Specification includes effects of ground offset voltage.

Optical Characteristics

Parameter	Symbol	Min.	Typ.	Max.	Unit	Notes
Transmitter						
Center Wavelength	λ	840		860	nm	
RMS spectral width				0.6	nm	1
Average launch power, per lane				4	dBm	
Average launch power, per lane		-6.5			dBm	
Outer Optical Modulation Amplitude (OMA _{outer}), per lane		-4.5		3	dBm	2
Launch power in OMA _{outer} minus TDECQ, per lane		-5.9			dBm	
Transmitter and dispersion eye closure for PAM4 (TDECQ), per lane				4.5	dB	
TDECQ – 10log ₁₀ (C _{eq}), per lane				4.5	dB	3
Average launch power of OFF transmitter, per lane				-30	dBm	
Extinction ratio		3			dB	
Transmitter transition time, per lane				34	ps	
RIN _{12OMA}				-128	dB/Hz	
Optical return loss tolerance				12	dB	
Encircled Flux			≥86% at 19μm ≤ 30% at 4.5μm			4
Receiver						
Center Wavelength	λ	840		860	nm	
Damage threshold, per lane			5		dBm	5
Average receive power, per lane				4	dBm	

Average receive power, per lane		-8.4			dBm	6
Receive power (OMA _{outer}), per lane				3	dBm	
Receiver reflectance				-12	dB	
Receiver sensitivity (OMA _{outer}), per lane				Equation (138-1)	dBm	7
Stressed receiver sensitivity (OMA _{outer}), per lane				-3.4	dBm	8
Conditions of stressed receiver sensitivity test						
LOS De-Assert				-9	dBm	
LOS Assert		-30		-10	dBm	
LOS Hysteresis		0.5			dB	
Stressed eye closure for PAM4 (SECQ), lane under test			4.5		dB	9
SECQ – $10\log_{10}(C_{eq})f$, each lane (max)			4.5		dB	9
OMA _{outer} of each aggressor lane			3		dBm	

Notes:

1. RMS spectral width is the standard deviation of the spectrum.
2. Even if the TDECQ < 1.4 dB, the OMA_{outer} (min) must exceed this value.
3. C_{eq} is a coefficient defined in 121.8.5.3, which accounts for the reference equalizer noise enhancement.
4. If measured into type A1a.2 or type A1a.3, or A1a.4, 50µm fiber, in accordance with IEC 61280-1-4.
5. The receiver shall be able to tolerate, without damage, continuous exposure to an optical input signal having this average power level on one lane. The receiver does not have to operate correctly at this input power.
6. Average receive power, each lane (min) is informative and not the principal indicator of signal strength. A received power below this value cannot be compliant; however, a value above this does not ensure compliance.
7. Receiver sensitivity is informative and is defined for a transmitter with a value of SECQ up to 4.5 dB (see Receiver Sensitivity Illustration below from IEEE 802.3cd clause 138).
8. Measured with conformance test signal at TP3 (see IEEE 802.3cd 138.8.10) for the BER of 2.4E-4.
9. C_{eq} is a coefficient defined in 121.8.5.3, which accounts for the reference equalizer noise enhancement.
10. These “Conditions of Stressed Receiver Sensitivity Test” are for measuring stressed receiver sensitivity. They are not characteristics of the receiver.

Receiver Sensitivity

Receiver Sensitivity is informative and is defined for a transmitter with a value of SECQ up to 4.5dB. Receiver Sensitivity should meet Equation (138-1).

$$RS = \max(-6.5, SECQ - 7.9) \text{ (dBm)} \quad (138-1)$$

Where

RS is the receiver sensitivity

SECQ is the SECQ of the transmitter for receivers is stressed receiver sensitivity.

The normative requirement for receivers is stressed receiver sensitivity.

Illustration of Receiver Sensitivity

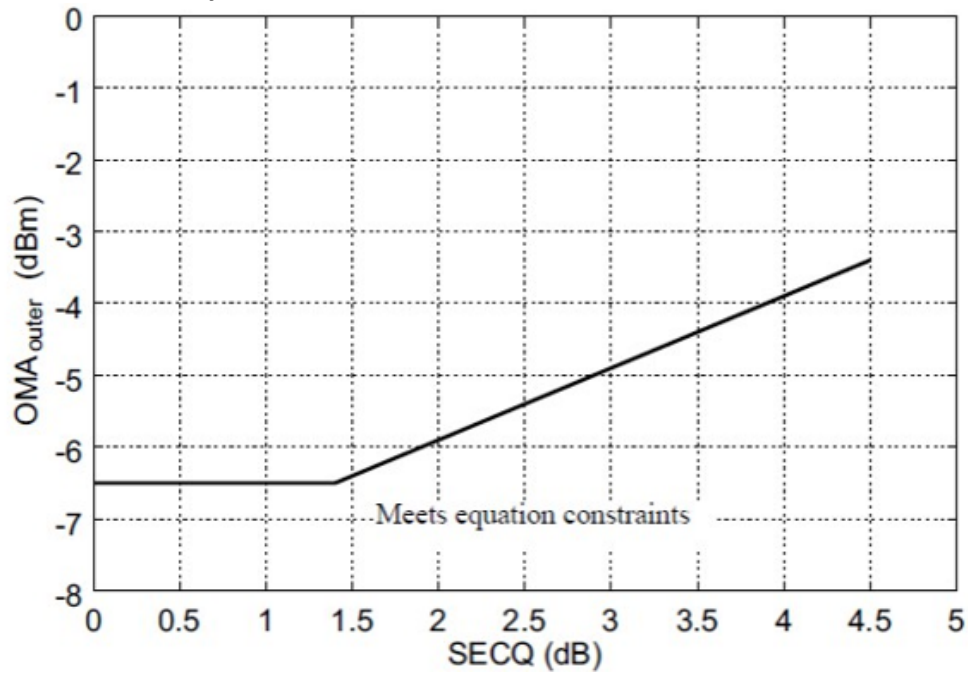

Pin Descriptions

Pin	Symbol	Description	Notes
1	GND	Ground.	1
2	Tx2-	Transmitter Inverted Data Input.	
3	Tx2+	Transmitter Non-Inverted Data Input.	
4	GND	Ground.	1
5	Tx4-	Transmitter Inverted Data Input.	
6	Tx4+	Transmitter Non-Inverted Data Input.	
7	GND	Ground.	1
8	ModSelL	Module Select.	
9	ResetL	Module Reset.	
10	VccRx	+3.3V Power Supply Receiver.	
11	SCL	2-Wire Serial Interface Clock.	
12	SDA	2-Wire Serial Interface Data.	
13	GND	Ground.	1
14	Rx3+	Receiver Non-Inverted Data Output.	
15	Rx3-	Receiver Inverted Data Output.	
16	GND	Ground.	1
17	Rx1+	Receiver Non-Inverted Data Output.	
18	Rx1-	Receiver Inverted Data Output.	
19	GND	Ground.	1
20	GND	Ground.	1
21	Rx2-	Receiver Inverted Data Output.	
22	Rx2+	Receiver Non-Inverted Data Output.	
23	GND	Ground.	1
24	Rx4-	Receiver Inverted Data Output.	
25	Rx4+	Receiver Non-Inverted Data Output.	
26	GND	Ground.	1
27	ModPrsL	Module Present.	
28	IntL	Interrupt.	
29	VccTx	+3.3V Power Supply Transmitter.	
30	Vcc1	+3.3V Power Supply.	
31	LPMode	Low-Power Mode.	
32	GND	Ground.	1
33	Tx3+	Transmitter Non-Inverted Data Input.	
34	Tx3-	Transmitter Inverted Data Input.	
35	GND	Ground.	1

36	Tx1+	Transmitter Non-Inverted Data Input.	
37	Tx1-	Transmitter Inverted Data Input.	
38	GND	Ground.	1

Notes:

1. Circuit ground is internally isolated from chassis ground.

Pin-Out Definitions

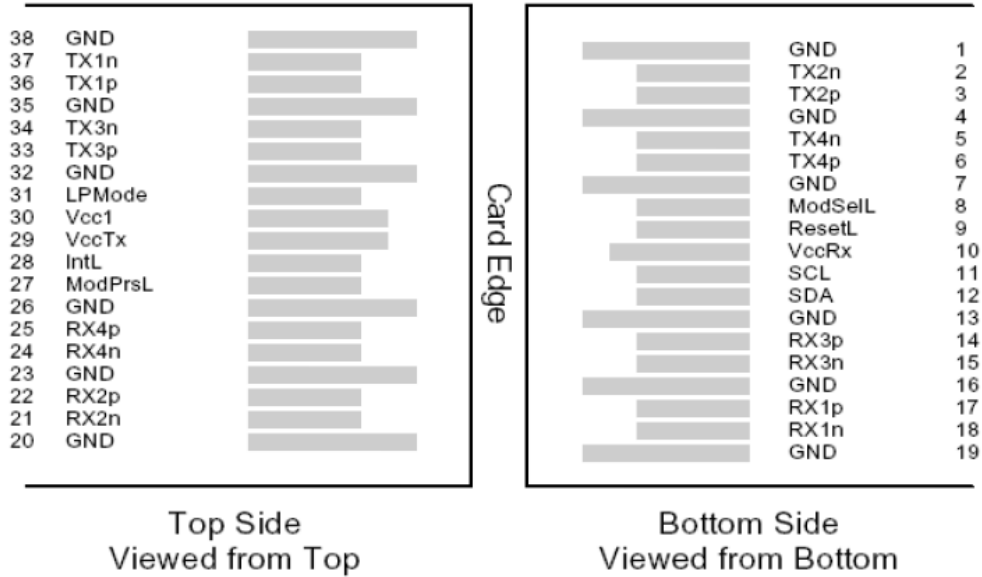

Mechanical Specifications

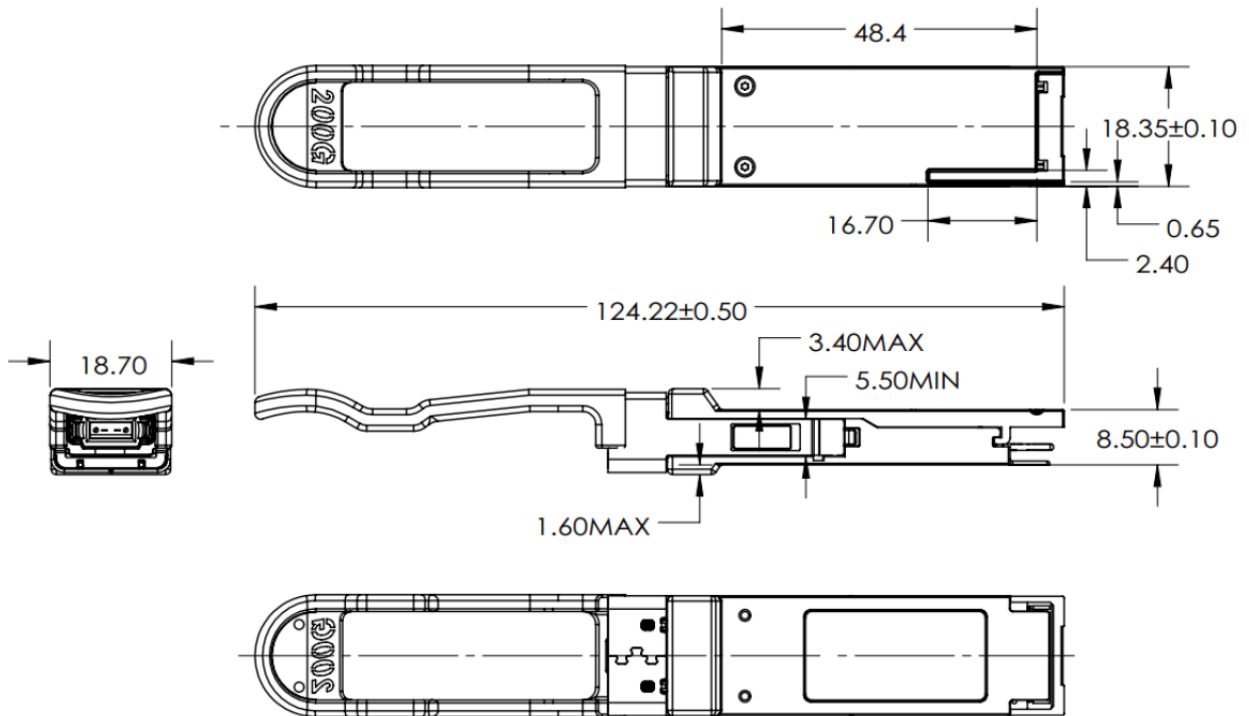

About ProLabs

Our extensive experience comes as standard. For over 20 years ProLabs has delivered optical connectivity solutions that give our customers freedom and choice through our ability to provide seamless interoperability. At the heart of our company is the ability to provide state-of-the-art optical transport and connectivity solutions that are compatible with more than 100 optical switching and transport platforms.

A Complete Portfolio of Network Solutions

ProLabs is focused on innovations in optical transport and connectivity. The combination of our knowledge of optics and networking equipment enables ProLabs to be your single source for optical transport and connectivity solutions from 100Mb to 1.6T while providing innovative solutions that increase network efficiency. We provide the optical connectivity expertise that is compatible with and enhances your switching and transport equipment.

The Trusted Partner

Customer service is our number one value. ProLabs has invested in people, labs and manufacturing capacity to ensure compatible products, and immediate answers to your questions. With Engineering and Manufacturing offices in the U.K. and U.S. augmented by field offices throughout the U.S., U.K. and Asia, ProLabs is able to be our customers best advocate 24 hours a day.



Contact Information

ProLabs US

Email: sales@prolabs.com

Telephone: 952-852-0252

ProLabs UK

Email: salessupport@prolabs.com

Telephone: +44 1285 719 600