

QSFP28-100GB-SR2-C

MSA and TAA 100GBase-SR2 QSFP28 Transceiver (MMF, 850nm, 100m, MPO, DOM)

Features:

- Supports 106.25Gbps
- MPO12 PC/APC Connector
- PIN and TIA array on the Receiver Side
- Compliant to SFF-8665 MSA
- Single 3.3V Power Supply
- Up to 100m Transmission on MMF OM4
- Up to 70m Transmission on MMF OM3
- VCSEL Transmitter
- Class 1 Laser
- Operating Temperature: 0 to 70 Celsius
- RoHS Compliant and Lead-Free

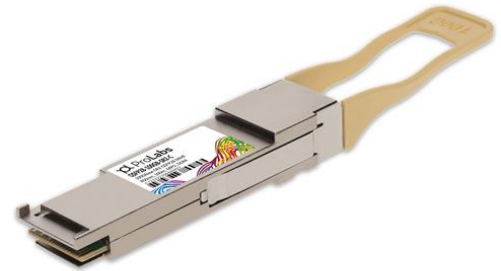

Applications:

- 100GBase Ethernet

Product Description

This MSA compliant QSFP28 transceiver provides 100GBase-SR2 throughput up to 100m over OM4 multi-mode fiber (MMF) using a wavelength of 850nm via an MPO connector. All of our transceivers are built to comply with Multi-Source Agreement (MSA) standards and are uniquely serialized and tested for data-traffic and application to ensure seamless network integration. Additional product features include Digital Optical Monitoring (DOM) support which allows access to real-time operating parameters. This transceiver is Trade Agreements Act (TAA) compliant. We stand behind the quality of our products and proudly offer a limited lifetime warranty.

ProLabs' transceivers are RoHS compliant and lead-free.

TAA refers to the Trade Agreements Act (19 U.S.C. & 2501-2581), which is intended to foster fair and open international trade. TAA requires that the U.S. Government may acquire only "U.S.-made or designated country end products."



Absolute Maximum Ratings

Parameter	Symbol	Min.	Typ.	Max.	Unit	Notes
Maximum Supply Voltage	V _{cc}	-0.5	3.3	3.6	V	
Storage Temperature	T _{stg}	-40		85	°C	
Relative Humidity	RH	5		85	%	
Operating Case Temperature	T _c	0		70	°C	
Power Supply Total Current				1212	mA	
AC Coupling Internal Capacitor			0.1		μV	
Modulation Format			PAM4			
Fiber Length	OM3			70	m	
	OM4			100	m	

Electrical Characteristics

Parameter	Symbol	Min.	Typ.	Max.	Unit	Notes
Module Supply Voltage	V _{cc}	3.135	3.3	3.6	V	
Power Supply Noise				25	mVp-p	1
Receiver Differential Data Output Load			100		Ω	
Power Consumption				4	W	

Notes:

1. Power Supply Noise is defined as the peak-to-peak noise amplitude over the frequency range at the host supply side of the recommended power supply filter with the module and recommended filter in place. Voltage levels including peak-to-peak noise are limited to the recommended operating range of the associated power supply.

High-Speed Electrical Characteristics

Parameter	Symbol	Min.	Typ.	Max.	Unit	Notes
@TP1 Test Point						
Signaling Rate Per Lane			25.78125 ± 100ppm			
Differential Pk-Pk Input Voltage Tolerance	TP1a	900			mV	1
Differential Input Return Loss	TP1	Equation (83E-5)			dB	2
Common- to Differential-Mode Conversion Return Loss	TP1	Equation (83E-6)			dB	2
Differential Termination Mismatch	TP1			10	%	
Single-Ended Voltage Tolerance Range	TP1a	-0.4		3.3	V	
DC Common-Mode Output Voltage	TP1	-350		2850	mV	3
Module Stressed Input Test	TP1a					4
Eye Width			0.46		UI	
Eye Height			95		mV	
Applied Pk-Pk Sinusoidal Jitter			Table 88-13			4
@TP4 Test Point						
Signaling Rate Per Lane			25.78125 ± 100ppm			
AC Common-Mode Output Voltage (RMS)	TP4			17.5	mV	
Differential Pk-Pk Output Voltage	TP4			900	mV	
Eye Width	TP4	0.57			UI	
Eye Height (Differential)	TP4	228			mV	
Vertical Eye Closure	TP4			5.5	dB	
Differential Output Return Loss	TP4	Equation (83E-2)				5
Common- to Differential-Mode Conversion Return Loss	TP4	Equation (83E-3)				5
Differential Termination Mismatch	TP4			10	%	
Transition Time (20-80%)	TP4			12	ps	
DC Common-Mode Voltage	TP4	-350		2850	mV	2

Notes:

- Equation (83E-5) and Equation (83E-6) refer to IEEE 802.3-2018.
- DC common-mode voltage is generated by the host. Specification includes the effects of ground offset voltage.
- Meets BER specified in 120E.1.1 of IEEE 802.3-2018.
- Table 88-13 refers to IEEE 802.3-2018.
- Equation (83E-2) and Equation (83E-3) refer to IEEE 802.3-2018.

Optical Characteristics

Parameter	Symbol	Min.	Typ.	Max.	Unit	Notes
@TP2 Test Point						
Signaling Rate Per Lane	DR		26.5625 ± 100ppm		GBd	
Center Wavelength	λ	840		868	nm	
RMS Spectral Width	$\Delta\lambda_{rms}$			0.6	nm	1
Average Launch Power Per Lane	P_{avg}	-6.5		4	dBm	
Outer Optical Modulation Amplitude (OMAouter) Per Lane	POMA	-4.5		3	dBm	2
Launch Power in OMAouter Minus TDECQ	OMA-TDECQ	-5.9			dBm	
Transmitter and Dispersion Eye Closure for PAM4 (TDECQ) Per Lane	TDECQ			4.5	dB	
TDECQ-10log ₁₀ (Ceq) Per Lane	TDECQ-10log ₁₀ (Ceq)			4.5	dB	3
Average Launch Power of Off Transmitter Per Lane	P_{off}			-30	dBm	
Extinction Ratio Per Lane	ER	3			dB	
RIN ₁₂ OMA	RIN ₁₂ OMA			-128	dB/Hz	
Optical Return Loss Tolerance	ORLT			12	dB	
Encircled Flux	EF		≥86% at 19μm ≤30% at 4.5μm			4
@TP3 Test Point						
Signaling Rate Per Lane	DR		26.5625 ± 100ppm		GBd	
Center Wavelength	λ	840		868	nm	
Damage Threshold		5			dBm	5
Average Receiver Power Per Lane		-8.4		4	dBm	6
Receiver Power Per Lane (OMAouter)				3	dBm	
Receiver Reflectance				-12	dB	
Stressed Receiver (OMAouter) Per Lane				-3.4	dB	7
LOS Assert	LOSA	-17			dBm	
LOS De-Assert	LOSD			-11	dBm	
Receiver Sensitivity (OMAouter) Per Lane			Max. (-6.5, SECQ-7.9)			8
Conditions of Stressed Receiver Sensitivity Test						
Stressed Eye Closure for PAM4 (SECQ) Per Lane Under Test			4.5		dB	9
SECQ-10log ₁₀ (Ceq) Per Lane Under Test				4.5	dB	9, 3
OMAouter of Each Aggressor Lane			3		dBm	9, 10

Notes:

1. RMS spectral width is the standard deviation of the spectrum.
2. Even if the TDECQ < 1.4dB, the OMAouter (minimum) must exceed this value.
3. Ceq is a coefficient defined in 121.8.5.3, which accounts for the reference equalizer noise enhancement.

4. If measured into type A1a.2 or type A1a.3, or A1a.4, 50µm fiber, in accordance with IEC 61280-1-4.
5. The receiver shall be able to tolerate, without damage, continuous exposure to an optical input signal having this average power level on one lane. The receiver does not have to operate correctly at this input power.
6. Average receive power, per lane (minimum), is informative and not the principal indicator of signal strength. A received power below this value cannot be compliant; however, a value above this does not ensure compliance.
7. Measured with conformance test signal at TP3 (see 138.8.10) for the BER specified in 138.1.1.
8. Receiver sensitivity is informative and is defined for a transmitter with a value of SECQ up to 4.5dB with $BER < 2.4 \times 10^{-4}$ without FEC in PRBS $2^{31}-1$.
9. These test conditions are for measuring stressed receiver sensitivity. They are not characteristics of the receiver.
10. Ceq is a coefficient defined in 121.8.5.3, which accounts for the reference equalizer noise enhancement.

Pin Descriptions

Pin	Logic	Symbol	Name/Description	Plug Sequence	Notes
1		GND	Module Ground.	1	1
2	CML-I	Tx2-	Transmitter Inverted Data Input (25G NRZ or 53G PAM4).	3	
3	CML-I	Tx2+	Transmitter Non-Inverted Data Input (25G NRZ or 53G PAM4).	3	
4		GND	Module Ground.	1	1
5	CML-I	Tx4-	Transmitter Inverted Data Input (25G NRZ or Not Used).	3	
6	CML-I	Tx4+	Transmitter Non-Inverted Data Input (25G NRZ or Not Used).	3	
7		GND	Module Ground.	1	1
8	LVTTTL-I	ModSelL	Module Select.	3	
9	LVTTTL-I	ResetL	Module Reset.	3	
10		VccRx	+3.3V Receiver Power Supply.	2	2
11	LVC MOS-I/O	SCL	2-Wire Serial Interface Clock.	3	
12	LVC MOS-I/O	SDA	2-Wire Serial Interface Data.	3	
13		GND	Module Ground.	1	1
14	CML-O	Rx3+	Receiver Non-Inverted Data Output (25G NRZ or Not Used).	3	
15	CML-O	Rx3-	Receiver Inverted Data Output (25G NRZ or Not Used).	3	
16		GND	Module Ground.	1	1
17	CML-O	Rx1+	Receiver Non-Inverted Data Output (25G NRZ or 53G PAM4).	3	
18	CML-O	Rx1-	Receiver Inverted Data Output (25G NRZ or 53G PAM4).	3	
19		GND	Module Ground.	1	1
20		GND	Module Ground.	1	1
21	CML-O	Rx2-	Receiver Inverted Data Output (25G NRZ or 53G PAM4).	3	
22	CML-O	Rx2+	Receiver Non-Inverted Data Output (25G NRZ or 53G PAM4).	3	

23		GND	Module Ground.	1	1
24	CML-O	Rx4-	Receiver Inverted Data Output (25G NRZ or Not Used).	3	
25	CML-O	Rx4+	Receiver Non-Inverted Data Output (25G NRZ or Not Used).	3	
26		GND	Module Ground.	1	1
27	LVTTTL-O	ModPrsL	Module Present.	3	
28	LVTTTL-O	IntL	Interrupt.	3	
29		VccTx	+3.3V Transmitter Power Supply.	2	2
30		Vcc1	+3.3V Power Supply.	2	2
31	LVTTTL-I	LPMode	Low-Power Mode.	3	
32		GND	Module Ground.	1	1
33	CML-I	Tx3+	Transmitter Non-Inverted Data Input (25G NRZ or Not Used).	3	
34	CML-I	Tx3-	Transmitter Inverted Data Input (25G NRZ or Not Used).	3	
35		GND	Module Ground.	1	1
36	CML-I	Tx1+	Transmitter Non-Inverted Data Input (25G NRZ or 53G PAM4).	3	
37	CML-I	Tx1-	Transmitter Inverted Data Input (25G NRZ or 53G PAM4).	3	
38		GND	Module Ground.	1	1

Notes:

1. GND is the symbol for signal and supply (power) common for the module. All are common within the module, and all module voltages are referenced to this potential unless otherwise noted. Connect these directly to the host board signal common ground plane.
2. VccRx, Vcc1, and VccTx are applied concurrently and maybe internally connected within the module in any combination. Vcc contacts in SFF-8662 and SFF-8672 each have a steady state current rating of 1A.

Pin-Out Definitions

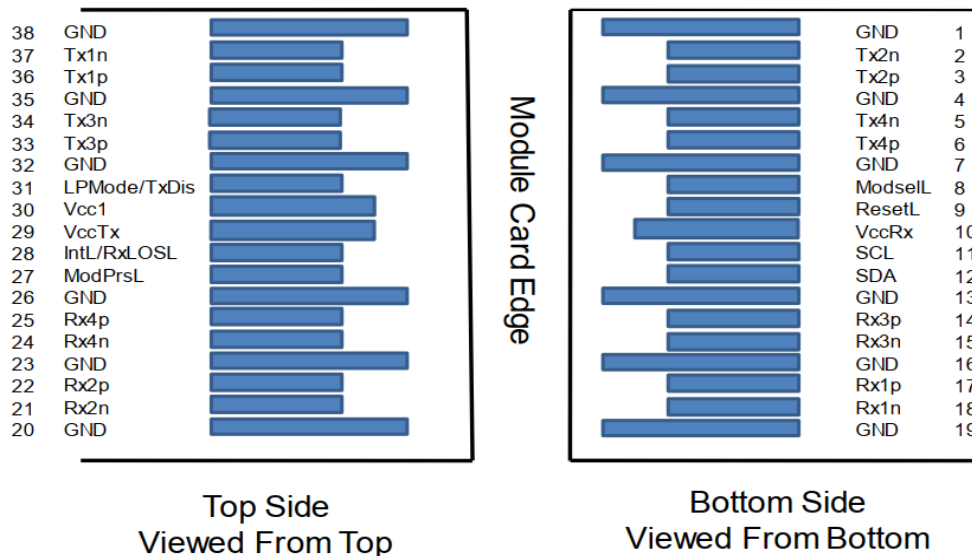

Top Side
Viewed From Top

Bottom Side
Viewed From Bottom

IEEE 802.3bm Compliance Points TP1a, TP4a

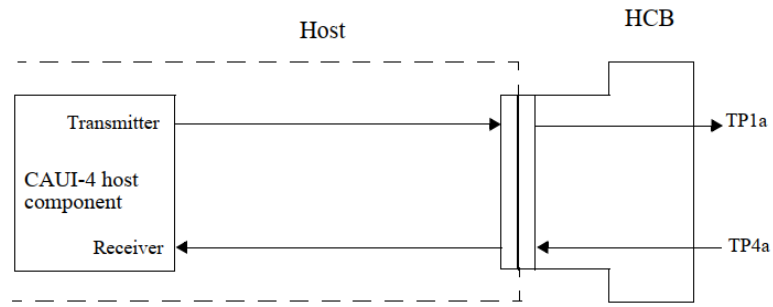

IEEE 802.3bm Compliance Points TP1, TP4

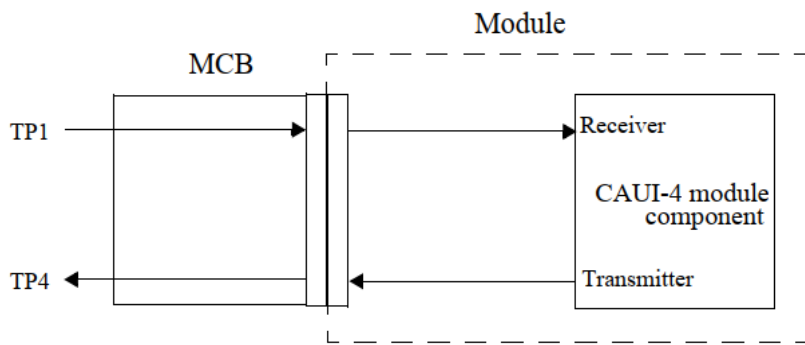

Host Board Power Supply Filter

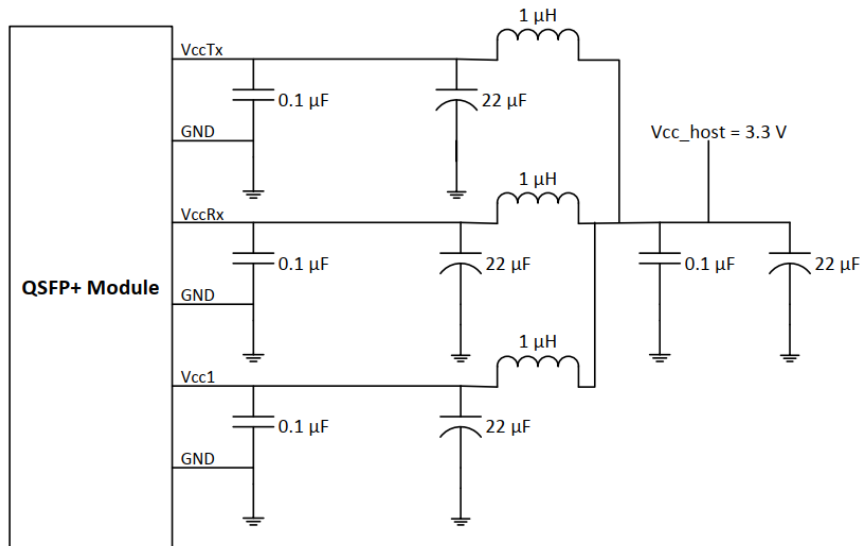

Mechanical Specifications

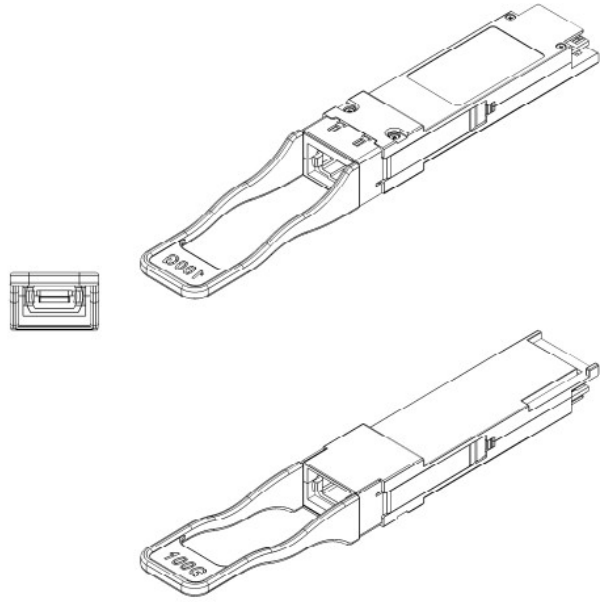
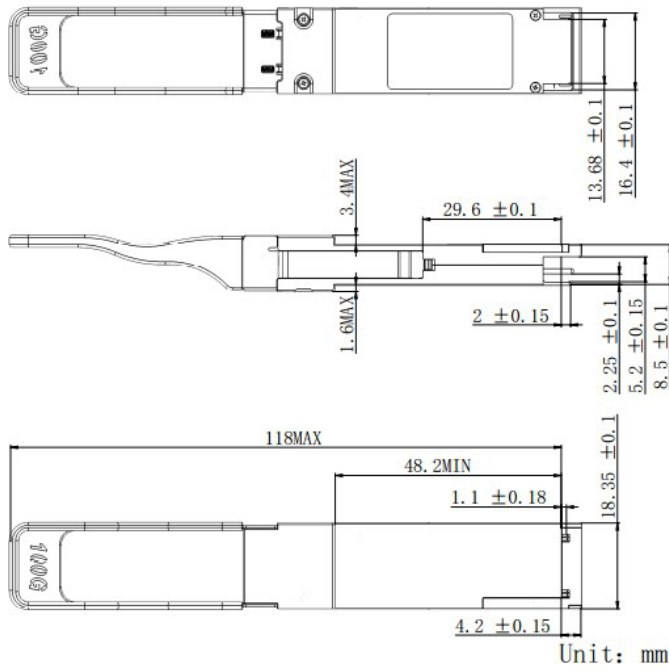

About ProLabs

Our extensive experience comes as standard. For over 20 years ProLabs has delivered optical connectivity solutions that give our customers freedom and choice through our ability to provide seamless interoperability. At the heart of our company is the ability to provide state-of-the-art optical transport and connectivity solutions that are compatible with more than 100 optical switching and transport platforms.

A Complete Portfolio of Network Solutions

ProLabs is focused on innovations in optical transport and connectivity. The combination of our knowledge of optics and networking equipment enables ProLabs to be your single source for optical transport and connectivity solutions from 100Mb to 1.6T while providing innovative solutions that increase network efficiency. We provide the optical connectivity expertise that is compatible with and enhances your switching and transport equipment.

The Trusted Partner

Customer service is our number one value. ProLabs has invested in people, labs and manufacturing capacity to ensure compatible products, and immediate answers to your questions. With Engineering and Manufacturing offices in the U.K. and U.S. augmented by field offices throughout the U.S., U.K. and Asia, ProLabs is able to be our customers best advocate 24 hours a day.



Contact Information

ProLabs US

Email: sales@prolabs.com

Telephone: 952-852-0252

ProLabs UK

Email: salessupport@prolabs.com

Telephone: +44 1285 719 600