

SFP56-50GBASE-SR-C

MSA and TAA 50GBase-SR SFP56 Transceiver (MMF, 850nm, 100m, LC, DOM)

Features:

- 850nm VCSEL Transmitter
- Power Dissipation of 1.5W
- Single 3.3V Power Supply
- Up to 100m over OM4
- Up to 70m over OM3
- Duplex LC Connector
- Hot-Pluggable
- Operating Temperature: 0 to 70 Celsius
- RoHS Compliant and Lead-Free



Applications:

- 50GBase Ethernet

Product Description

This MSA compliant SFP56 transceiver provides 50GBase-SR throughput up to 100m over multi-mode fiber (MMF) using a wavelength of 850nm via an LC connector. It can operate at temperatures between 0 and 70C. All of our transceivers are built to comply with Multi-Source Agreement (MSA) standards and are uniquely serialized and tested for data-traffic and application to ensure seamless network integration. Additional product features include Digital Optical Monitoring (DOM) support which allows access to real-time operating parameters. This transceiver is Trade Agreements Act (TAA) compliant. We stand behind the quality of our products and proudly offer a limited lifetime warranty.

ProLabs' transceivers are RoHS compliant and lead-free.

TAA refers to the Trade Agreements Act (19 U.S.C. & 2501-2581), which is intended to foster fair and open international trade. TAA requires that the U.S. Government may acquire only "U.S.-made or designated country end products."



Absolute Maximum Ratings

Parameter	Symbol	Min.	Typ.	Max.	Unit	Notes
Storage Temperature	Tstg	-40		85	°C	
Operating Case Temperature	Tc	0		70	°C	1
Relative Humidity	RH	5		85	%	
3.3V Power Supply Voltage	Vcc	-0.5	3.3	3.6	V	
Receiver Differential Data Output Load			100		Ω	
Fiber Length MMF	OM3			70	m	
	OM4			100	m	

Notes:

1. Continuous operation at the maximum Recommended Operating Case Temperature should be avoided to maintain reliability of the device.

Operating Temperature Measuring Point

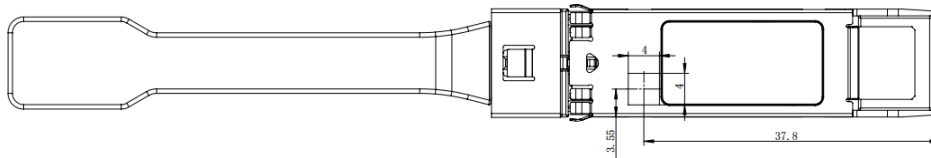

Electrical Characteristics

Parameter	Symbol / Test Point	Min.	Typ.	Max.	Unit	Notes
Power Supply Voltage	Vcc	3.135	3.3	3.465	V	
Power Supply Noise				25	mVp-p	1
Power Consumption				1.5	W	
Power Supply Current				454	mA	
High-Speed Input Characteristics						
Signaling Rate (PAM4)	TP1		26.5625 ± 100ppm		GBd	
Differential Peak-Peak Input Voltage Tolerance (Min.)	TP1a	900			mV	
Differential Input Return Loss (Min.)	TP1	Equation (83E-5)			dB	2
Differential- to Common-Mode Input Return Loss (Min.)	TP1	Equation (83E-6)			dB	2
Differential Termination Mismatch (Max.)	TP1			10	%	
Single-Ended Voltage Tolerance Range	TP1a	-0.4		3.3	V	
DC Common-Mode Output Voltage	TP1	-350		2850	mV	3
Module Stressed Input Test	TP1a					4

Eye Width			0.22		UI	
Applied Peak-Peak Sinusoidal Jitter			Table 120E-6			2
Eye Height			32		mV	
High-Speed Output Characteristics						
Signaling Rate (PAM4)	TP4		26.5625 ± 100ppm		GBd	
AC Common-Mode Output Voltage (Max., RMS)	TP4			17.5	mV	
Differential Peak-Peak Output Voltage (Max.)	TP4			900	mV	
Near-End ESMW (Eye Symmetry Mask Width)	TP4	0.265			UI	
Near-End Eye Height Differential (Min.)	TP4	70			mV	
Differential Output Return Loss (Min.)	TP4	Equation (83E-2)			dB	5
Common- to Differential-Mode Conversion Return Loss (Min.)	TP4	Equation (83E-3)			dB	5
Differential Termination Mismatch (Max.)	TP4			10	%	
Transition Time (Min., 20-80%)	TP4	9.5			ps	
DC Common-Mode Voltage	TP4	-350	2850		mV	

Notes:

1. Power Supply Noise is defined as the peak-peak noise amplitude over the frequency range at the host supply side of the recommended power supply filter with the module and recommended filter in place. Voltage levels including peak-peak noise are limited to the recommended operating range of the associated power supply.
2. Equation (83E-5), Equation (83E-6), and Table120E-6 refer to 802.3-2018.
3. DC common-mode voltage is generated by the host. Specification includes the effects of ground offset voltage.
4. Module stressed input tolerance is measured using the procedure defined in 120E-8 IEEE802.3-2018.
5. Equation (83E-2) and Equation (83E-3) refer to 802.3-2018.

50GBase Optical Characteristics

Parameter	Symbol	Min.	Typ.	Max.	Unit	Notes
@TP2 Test Point						
Signaling Speed			26.5625 ± 100ppm		GBd	
Modulation Format			PAM4			
Center Wavelength	λ	840		860	nm	
RMS Spectral Width	RMS			0.6	nm	
Extinction Ratio	ER	3.0			dB	
Transmitter Transition Time				34	ps	
Average Launch Power		-6.5		4	dBm	1
Outer Optical Modulation Amplitude (OMA)		-4.5		3	dBm	
Launch Power in OMA-TDECQ		-5.9			dBm	
TDECQ (PAM4)				4.5	dB	
TDECQ-10log ₁₀ (C _{eq})				4.5	dB	
RIN ₁₂ OMA				-128	dB/Hz	
Average Launch Power of Off Transmitter				-30	dBm	
Optical Return Loss Tolerance				12	dB	
Encircled Flux	19 μ m	86				%
	4.5 μ m			30		%
@TP3 Test Point						
Signaling Speed			26.5625 ± 100ppm		GBd	
Modulation Format			PAM4			
Center Wavelength	λ	840		860	nm	
Damage Threshold		5			dBm	
Average Receiver Power		-8.4		4	dBm	
Receiver Power Per Lane (OMA _{outer})				3		
Receive Sensitivity (OMA _{outer}) (BER<2.4E ⁻⁴)					dBm	2
Stressed Receiver Sensitivity (OMA _{outer}) (BER<2.4E ⁻⁴)				-3.4	dBm	
LOS Assert (Average)	LOSA	-17			dBm	
LOS De-Assert (Average)	LOSD			-11	dBm	
Receiver Reflectance				-12	dB	

Notes:

1. Average launch power (minimum) is informative and not the principal indicator of signal strength. A transmitter with launch power below this value cannot be compliant; however, a value above this does not ensure compliance.
2. Receiver sensitivity (OMA_{outer}) = max. (-6.5, SECQ-7.9).

25GBase Optical Characteristics

Parameter	Symbol	Min.	Typ.	Max.	Unit	Notes
@TP2 Test Point						
Signaling Speed			25.78125 ± 100ppm		GBd	
Modulation Format			NRZ			
Center Wavelength	λ	840		860	nm	
RMS Spectral Width	RMS			0.6	nm	
Extinction Ratio	ER	2.0			dB	
Average Launch Power		-8.4		2.4	dBm	
Outer Optical Modulation Amplitude (OMA)		-6.4		3	dBm	
Launch Power in OMA-TDECQ		-7.3			dBm	
Transmitter and Dispersion Eye Closure Per Lane				4.3	dB	
Transmitter Eye Mask Definition : (X1, X2, X3, Y1, Y2, Y3)			IEEE 802.3bm 25GBase-SR			1
Average Launch Power of Off Transmitter				-30	dBm	
Optical Return Loss Tolerance				12	dB	
Encircled Flux	19 μ m	86				%
	4.5 μ m			30		%
@TP3 Test Point						
Signaling Speed			25.78125 ± 100ppm		GBd	
Modulation Format			NRZ			
Center Wavelength	λ	840		860	nm	
Damage Threshold		3.4			dBm	
Average Receiver Power		-10.3		2.4	dBm	
Receive Sensitivity (OMA _{outer}) (BER<5E ⁻⁵ , with a 2 ³¹ -1 PRBS)				-10.3	dBm	
Stressed Receiver Sensitivity (OMA _{outer}) (BER<5E ⁻⁵ , with a 2 ³¹ -1 PRBS)				-5.2	dBm	
Conditions of Stressed Receiver Sensitivity Test						
Stressed Eye Closure	SEC		4.3		dB	
Stressed Eye J2 Jitter	J2		0.39		UI	
Stressed Eye J4 Jitter	J4		0.59		UI	
OMA of Each Aggressor Lane			3		dBm	
LOS Assert (Average)	LOSA	-30			dBm	
LOS De-Assert (Average)	LOSD			-13	dBm	
Receiver Reflectance				-12	dB	
Stressed Receiver Eye Mask Definition: (X1, X2, X3, Y1, Y2, Y3)			IEEE 802.3bm 25GBase-SR			

Notes:

1. Filtered, measured with a PRBS $2^{31}-1$ test pattern @25.78Gbps.

10GBase Optical Characteristics

Parameter	Symbol	Min.	Typ.	Max.	Unit	Notes
@TP2 Test Point						
Signaling Speed			10.3125 ± 100ppm		GBd	
Modulation Format			NRZ			
Center Wavelength	λ	840		860	nm	
RMS Spectral Width	RMS			0.6	nm	
Extinction Ratio	ER	3.0			dB	
Average Launch Power		-7.3		1.5	dBm	
Outer Optical Modulation Amplitude (OMA)		-4.3			dBm	
Transmitter and Dispersion Penalty				3.9	dB	
Average Launch Power of Off Transmitter				-30	dBm	
Optical Return Loss Tolerance				12	dB	
Transmitter Eye Mask Definition: (X1, X2, X3, Y1, Y2, Y3)			IEEE 802.3ae-2002			1
Encircled Flux	19 μ m	86			%	
	4.5 μ m			30	%	
@TP3 Test Point						
Signaling Speed			10.3125 ± 100ppm		GBd	
Modulation Format			NRZ			
Center Wavelength	λ	840		860	nm	
Damage Threshold		1			dBm	
Average Receiver Power		-9.9		-1	dBm	
Receive Sensitivity (OMA_{outer}) (BER<1E ⁻¹² , with a $2^{31}-1$ PRBS)				-11.1	dBm	
Stressed Receiver Sensitivity (OMA_{outer}) (BER<1E ⁻¹² , with a $2^{31}-1$ PRBS)				-7.5	dBm	
Conditions of Stressed Receiver Sensitivity Test						
Vertical Eye Closure Penalty (VECP)			3.5		dB	
LOS Assert (Average)	LOSA	-30			dBm	
LOS De-Assert (Average)	LOSD			-13	dBm	
Receiver Reflectance				-12	dB	

Notes:

1. Filtered, measured with a PRBS $2^{31}-1$ test pattern @25.78Gbps.

Pin Descriptions

Pin	Symbol	Name/Descriptions	Plug Sequence	Notes
1	VeeT	Transmitter Ground.	1	1
2	Tx_Fault	Transmitter Fault Indication.	3	2
3	Tx_Disable	Transmitter Disable.	3	3
4	SDA	2-Wire Serial Interface Data.	3	
5	SCL	2-Wire Serial Interface Clock.	3	
6	MOD_ABS	Module Absent.	3	
7	RS0	Rate Select 0.	3	
8	Rx_LOS	Receiver Loss of Signal Indication.	3	2
9	RS1	Rate Select 1.	3	
10	VeeR	Receiver Ground.	1	1
11	VeeR	Receiver Ground.	1	1
12	RD-	Receiver Inverted Data Output.	3	
13	RD+	Receiver Non-Inverted Data Output.	3	
14	VeeR	Receiver Ground.	1	1
15	VccR	Receiver 3.3V Supply.	2	
16	VccT	Transmitter 3.3V Supply.	2	
17	VeeT	Transmitter Ground.	1	1
18	TD+	Transmitter Non-Inverted Data Input.	3	
19	TD-	Transmitter Inverted Data Input.	3	
20	VeeT	Transmitter Ground.	1	1

Notes:

1. The module signal ground contacts, VeeR and VeeT, should be isolated from the module case.
2. This contact is an open collector/drain output contact and shall be pulled up on the host. Pull-ups can be connected to one of several power supplies; however, the host board design shall ensure that no module contact has voltage exceeding the module $V_{ccT/R} + 0.5V$.
3. Tx_Disable is an input contact with a resistor to the VccT inside the module.

Electrical Pad Layout

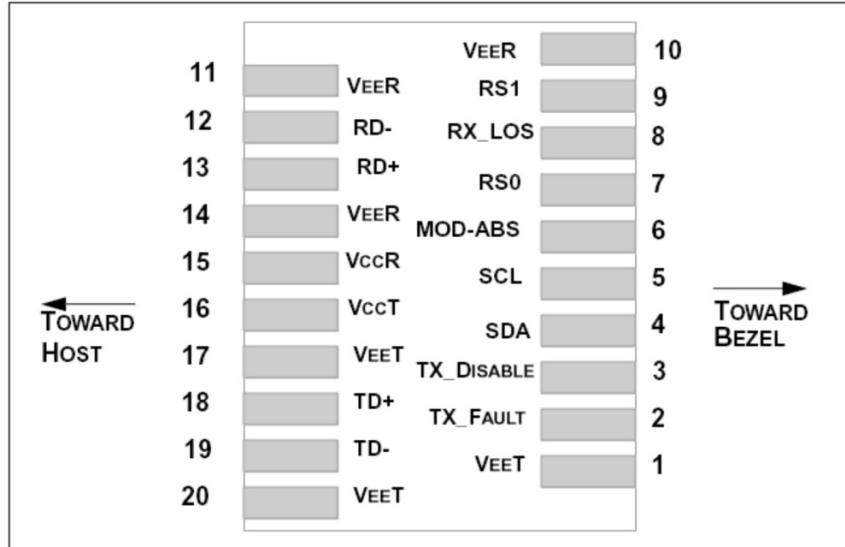

Pin Assignments

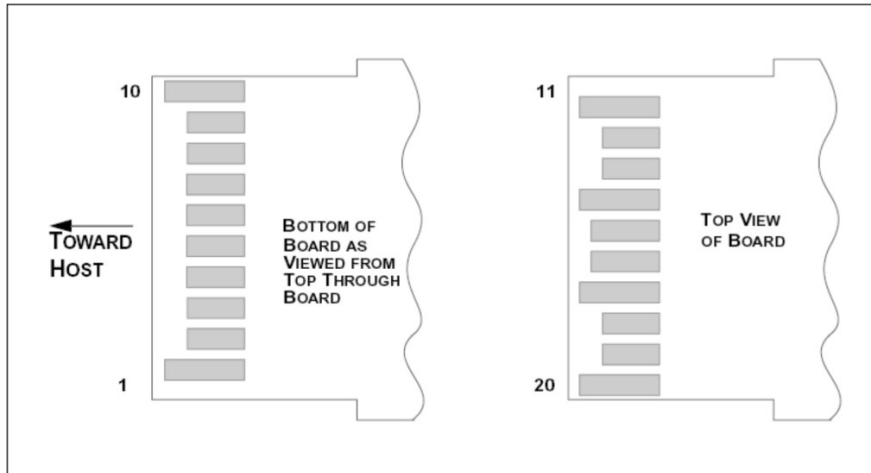

Power Supply Filter

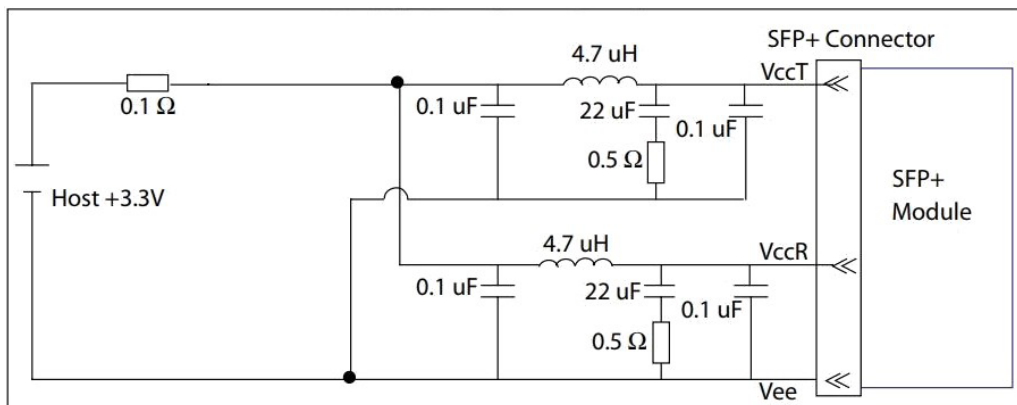

IEEE 802.3cd Block Diagram Transmit/Receive Paths (One Lane Per Direction)

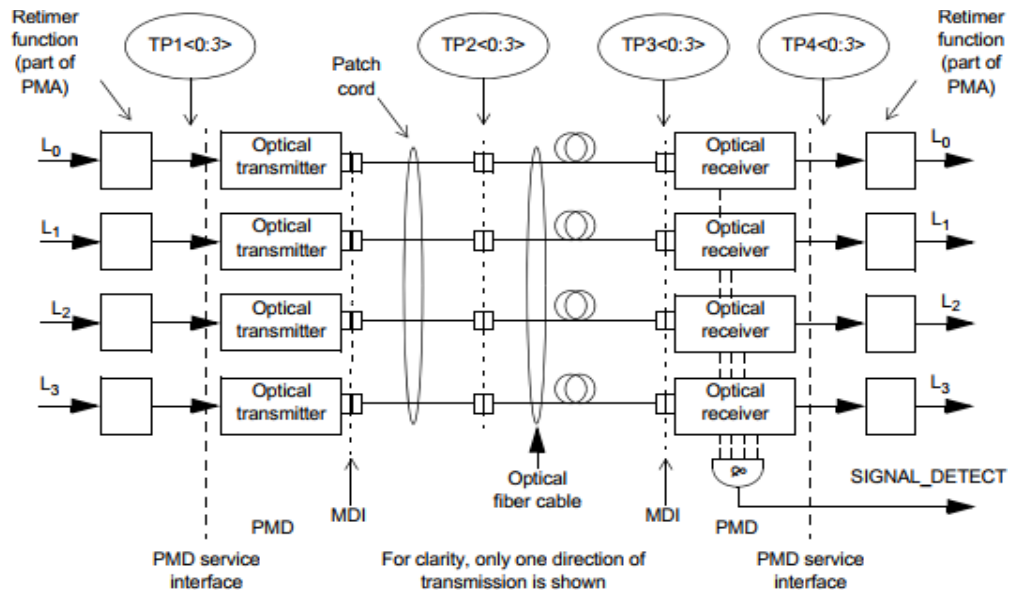

IEEE 802.3bs200GAUI-4 Compliance Points TP1a, TP4a

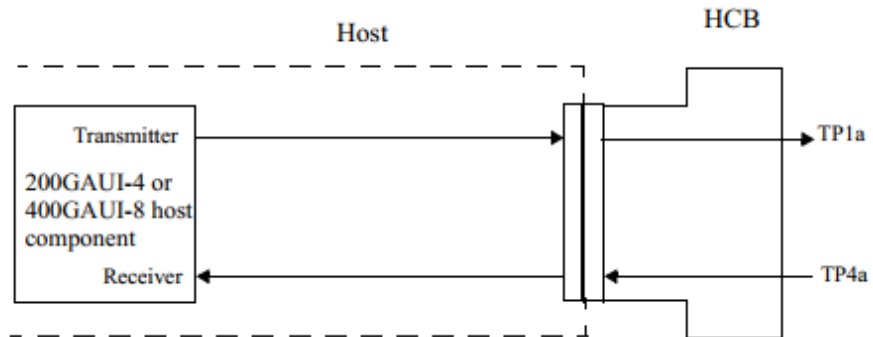

IEEE 802.3bs200GAUI-4 Compliance Points TP1, TP4

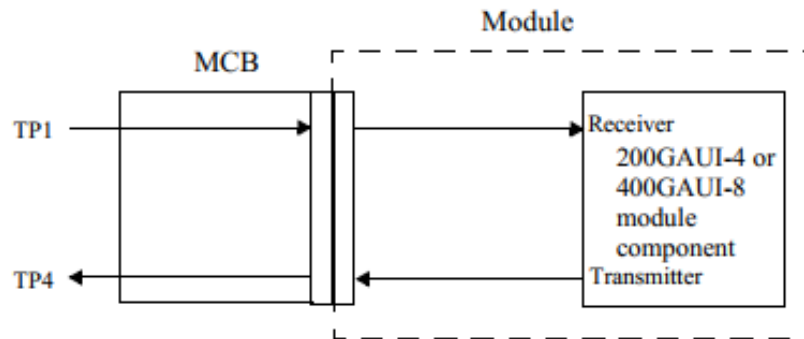

Block Diagram of Transceiver

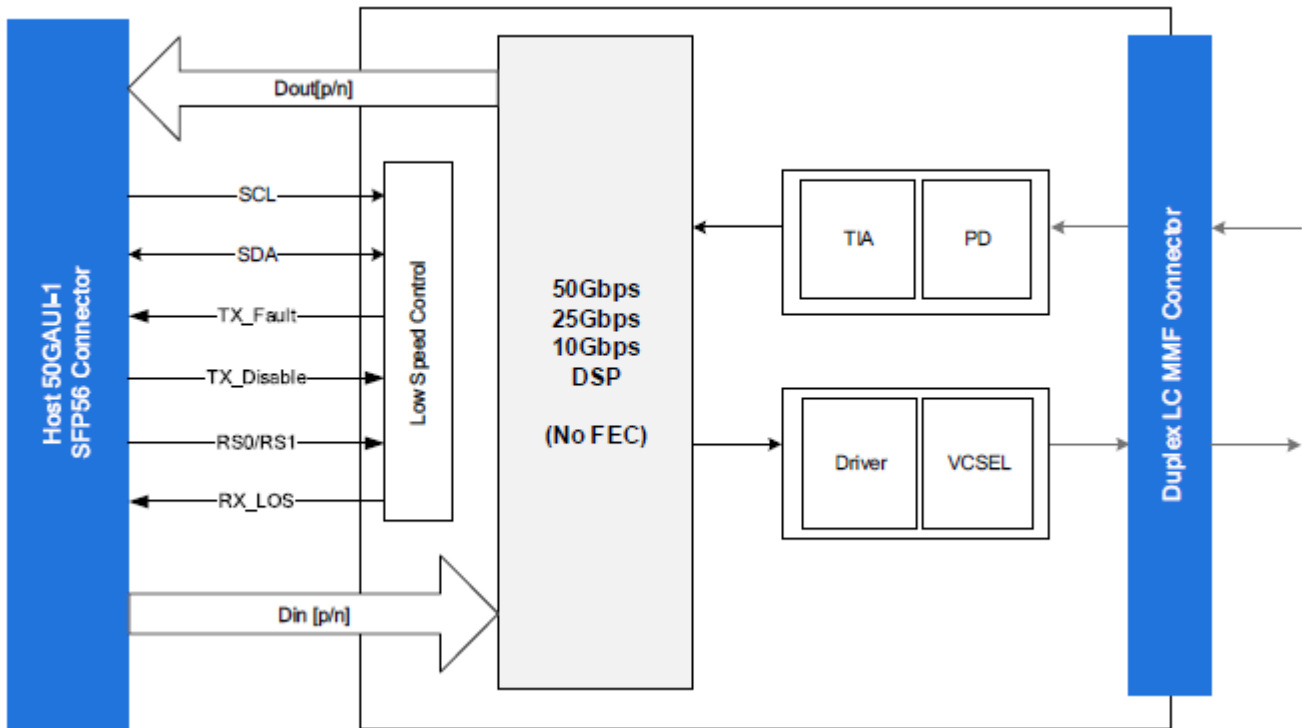

Application Reference Diagram

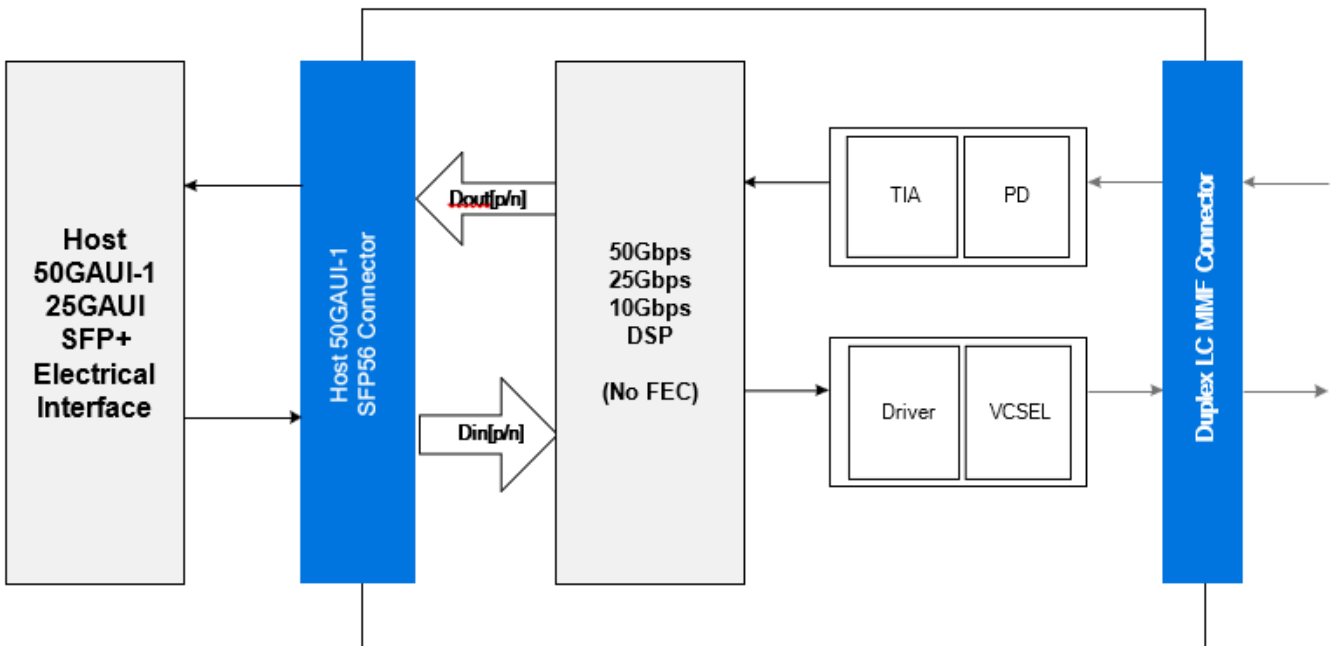

Mechanical Specifications

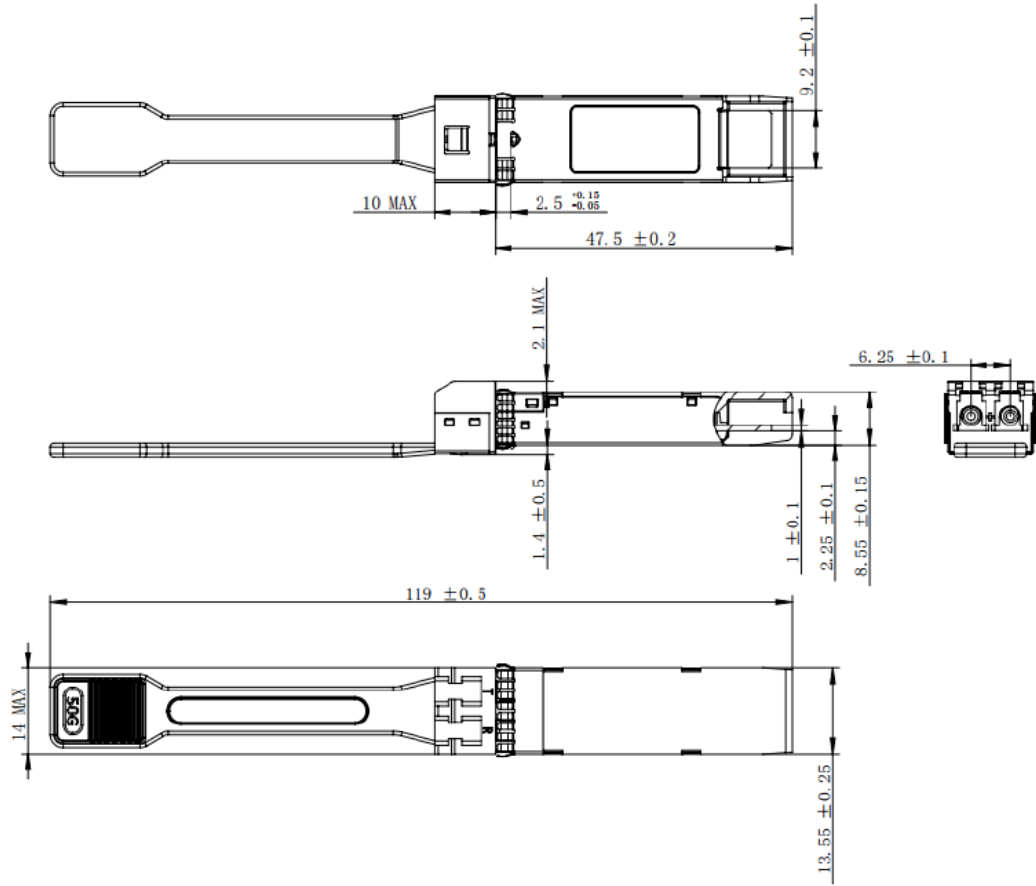

About ProLabs

Our extensive experience comes as standard. For over 20 years ProLabs has delivered optical connectivity solutions that give our customers freedom and choice through our ability to provide seamless interoperability. At the heart of our company is the ability to provide state-of-the-art optical transport and connectivity solutions that are compatible with more than 100 optical switching and transport platforms.

A Complete Portfolio of Network Solutions

ProLabs is focused on innovations in optical transport and connectivity. The combination of our knowledge of optics and networking equipment enables ProLabs to be your single source for optical transport and connectivity solutions from 100Mb to 1.6T while providing innovative solutions that increase network efficiency. We provide the optical connectivity expertise that is compatible with and enhances your switching and transport equipment.

The Trusted Partner

Customer service is our number one value. ProLabs has invested in people, labs and manufacturing capacity to ensure compatible products, and immediate answers to your questions. With Engineering and Manufacturing offices in the U.K. and U.S. augmented by field offices throughout the U.S., U.K. and Asia, ProLabs is able to be our customers best advocate 24 hours a day.



Contact Information

ProLabs US

Email: sales@prolabs.com

Telephone: 952-852-0252

ProLabs UK

Email: salessupport@prolabs.com

Telephone: +44 1285 719 600