

### XFP-EPON-OLT-PR30B-I-C

MSA and TAA 10GBase-OLT XFP Transceiver (SMF, 1577nmTx/1270nmRx, 20km, SC, DOM, -40 to 85C, BEAD Compliant)

#### Features:

- SC Optical Connector
- LVCMC AC/DC Coupled Input and Output
- 1577nm CW Mode EML
- 1270nm Burst-Mode APD/TIA Receiver
- 3.3V DC Power Supply
- Hot-Pluggable
- Operating Temperature: 0 to 70 Celsius
- RoHS Compliant and Lead-Free



#### Applications:

- PON
- Broadband Access

#### Product Description

This MSA compliant XFP transceiver provides 10GBase-OLT throughput up to 20km over single-mode fiber (SMF) using a wavelength of 1577nmTx/1270nmRx via a SC connector. It can operate at temperatures between -40 and 85C. It is built to MSA standards and is uniquely serialized and data-traffic and application tested to ensure that they will integrate into your network seamlessly. Digital optical monitoring (DOM) support is also present to allow access to real-time operating parameters. This transceiver is Trade Agreements Act (TAA) compliant. We stand behind the quality of our products and proudly offer a limited lifetime warranty.

ProLabs' transceivers are RoHS compliant and lead-free.

TAA refers to the Trade Agreements Act (19 U.S.C. & 2501-2581), which is intended to foster fair and open international trade. TAA requires that the U.S. Government may acquire only "U.S.-made or designated country end products.")



## Absolute Maximum Ratings

Parameter	Symbol	Min.	Max.	Unit
Operating Case Temperature	T <sub>c</sub>	-40	85	°C
Storage Temperature	T <sub>stg</sub>	-40	85	
Relative Storage Humidity	RH <sub>stg</sub>	0	95	%
Relative Operating Humidity	RH <sub>o</sub>	0	85	%
Module Supply Voltage	V <sub>cc</sub>	0	3.6	V

### Notes:

- Exceeding the Absolute Maximum Ratings may cause irreversible damage to the device. The device is not intended to be operated under the condition of simultaneous Absolute Maximum Ratings, a condition which may cause irreversible damage to the device.

## Electrical Characteristics

Parameter	Symbol	Min.	Typ.	Max.	Unit	Notes
Power Supply Voltage	V <sub>cc</sub>	3.135	3.3	3.465	V	
Power Supply Current	I <sub>cc</sub>		650	1000	mA	
<b>Transmitter</b>						
Tx Differential Input Impedance	Z <sub>IN</sub>	90	100	110	Ω	
10Gbps Tx Differential Input Amplitude	V <sub>IN10</sub>	120		820	mV	
Tx_Disable = High (Transmitter Off/Disabled)	V <sub>TDH</sub>	2.0		V <sub>cc3</sub> +0.3	V	1
Tx_Disable = Low (Transmitter On/Enabled)	V <sub>TDL</sub>	0		0.8	V	1
<b>Parameter</b>						
Rx Differential Output Impedance	Z <sub>OUT</sub>	90	100	110	Ω	
10Gbps Rx_Data Differential Output Voltage Amplitude	V <sub>OUT10</sub>		700		mV	
10Gbps Output High Voltage	V <sub>OH10</sub>	V <sub>cc3</sub> -20	V <sub>cc3</sub> -5	V <sub>cc3</sub>	mV	
10Gbps Output Low Voltage	V <sub>OL10</sub>	V <sub>cc3</sub> -400	V <sub>cc3</sub> -350	V <sub>cc3</sub> -300	mV	
Rx_LOS = High (Receiver Off)	V <sub>OH</sub>	2.0		V <sub>cc</sub> +0.3	V	2
Rx_LOS = Low (Receiver On)	V <sub>OL</sub>	0		0.8	V	2
<b>Control Function Logic Levels</b>						
Tx_Disable	Tx_Dis	0		V <sub>cc3</sub> +0.5	V	3
Burst-Mode Loss of Signal	Rx_LOS	0		V <sub>cc3</sub> +0.5	V	3
Rx_RateSelect	Rx_RateSel	0		V <sub>cc3</sub> +0.5	V	4
Digital Rx_RSSI_Trigger Input	TRI	0		V <sub>cc3</sub> +0.5	V	4
I <sup>2</sup> C Serial Data	SDA	0		V <sub>cc3</sub> +0.5	V	5
I <sup>2</sup> C Serial Clock	SCL	0		V <sub>cc3</sub> +0.5	V	4

**Notes:**

1. LVTTTL control input.
2. LVTTTL monitor output.
3. LVTTTL.
4. Single-ended LVTTTL input.
5. Single-ended LVTTTL I/O.

**Optical Characteristics**

Parameter	Symbol	Min.	Typ.	Max.	Unit	Notes
<b>Transmitter</b>						
Laser Type		1577nm CW EML				
Downstream Signal Rate			10.3125		Gbps	
Average Launch Power	P	2		5	dBm	
Optical Center Wavelength	$\lambda_{10}$	1575	1577	1580	nm	
Spectral Width	$\Delta\lambda_{10}$			1	nm	
Side-Mode Suppression Ratio	SMSR <sub>10</sub>	30			dB	
Extinction Ratio	ER <sub>10</sub>	6			dB	
Output Eye Diagram		Compliant with IEEE802.3av				
<b>Receiver</b>						
Receiver Type		1270nm APD/TIA Receiver				
Upstream Signal Rate		10.3125			Gbps	
Optical Center Wavelength	$\lambda$	1260	1270	1280	nm	
Receiver Sensitivity	P <sub>IN</sub>			-28	dBm	
Receiver Optical Overload	P <sub>IN(SAT)</sub>	-6			dBm	1
Damaged Input Optical Power	P <sub>d</sub>	-5			dBm	1
Receiver Settling Time	T <sub>rx</sub>			800	ns	
Rx_LOS Assert	P <sub>a</sub>	-45			dBm	
Rx_LOS De-Assert	P <sub>d</sub>			-28.5	dBm	
Rx_LOS Hysteresis	Phy	0.5		5	dB	

**Notes:**

1. BER@10<sup>-3</sup>, PRBS 2<sup>31</sup>-1, and ER=6dB.

## Pin Descriptions

Pin	Symbol	Name/Description	Notes
1	GND	Module Ground.	
2	1G_Tx+	Transmit Non-Inverted 1.25Gbps Data Input. AC coupled inside the module.	
3	1G_Tx-	Transmit Inverted 1.25Gbps Data Input. AC coupled inside the module.	
4	GND	Module Ground.	
5	Tx_Dis	Transmit Disable. When asserted "high," both 10Gbps and 1.25Gbps transmitters' output are turned off.	1
6	NC	Not Connected. Reserved for rate select for future use.	
7	GND	Module Ground.	
8	Vcc3	+3.3V Power Supply.	
9	Vcc3	+3.3V Power Supply.	
10	SCL	2-Wire Serial Interface Clock.	2
11	SDA	2-Wire Serial Interface Data.	2
12	MOD_ABS	Module Ground. "High" stands for "module is physically absent."	2
13	NC	Not Connected. Reserved for rate select for future use.	3
14	Rx_LOS	Rx Loss of Signal Indication Output.	2
15	GND	Module Ground.	
16	GND	Module Ground.	
17	10G_Rx-	Receive Burst-Mode Inverted 10.3125Gbps Data Output. DC coupled inside the module.	
18	10G_Rx+	Receive Burst-Mode Non-Inverted 10.3125Gbps Data Output. DC coupled inside the module.	
19	GND	Module Ground.	
20	1G_Rx-	Receive Burst-Mode Inverted 1.25Gbps Data Output. DC coupled inside the module.	
21	1G_Rx+	Receive Burst-Mode Non-Inverted 1.25Gbps Data Output. DC coupled inside the module.	
22	NC	Not Connected.	
23	Rx_RSSI_TRI	Receiver Signal Strength Indication Trigger Input for Digital RSSI. Digital RSSI can be read from I2C.	3
24	NC	Not Connected.	
25	NC	Not Connected.	
26	NC	Not Connected.	
27	GND	Module Ground.	
28	10G_Tx-	Transmit Inverted 10.3125Gbps Data Input. AC coupled inside the module.	
29	10G_Tx+	Transmit Non-Inverted 10.3125Gbps Data Input. AC coupled inside the module.	
30	GND	Module Ground.	

### Notes:

1. Internal 4.7k $\Omega$  to 10k $\Omega$  pull-up to the Vcc3.
2. Shall be pulled up with 4.7k $\Omega$  to 10k $\Omega$  to a voltage between 3.15V and 3.6V on the host board.
3. A 200 $\Omega$  resistance shall be put in series on the host board.

## Pin Assignment

TOP VIEW  
OF BOARD

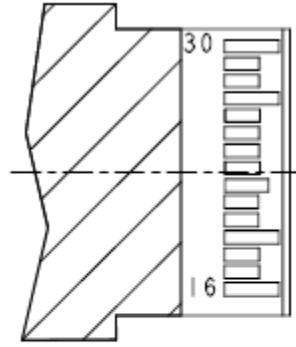

BOTTOM VIEW  
OF BOARD

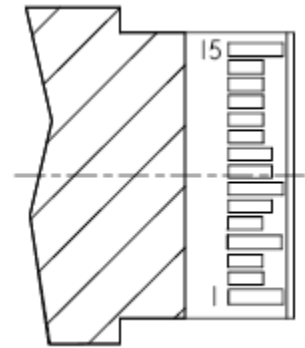

## Electrical Interface

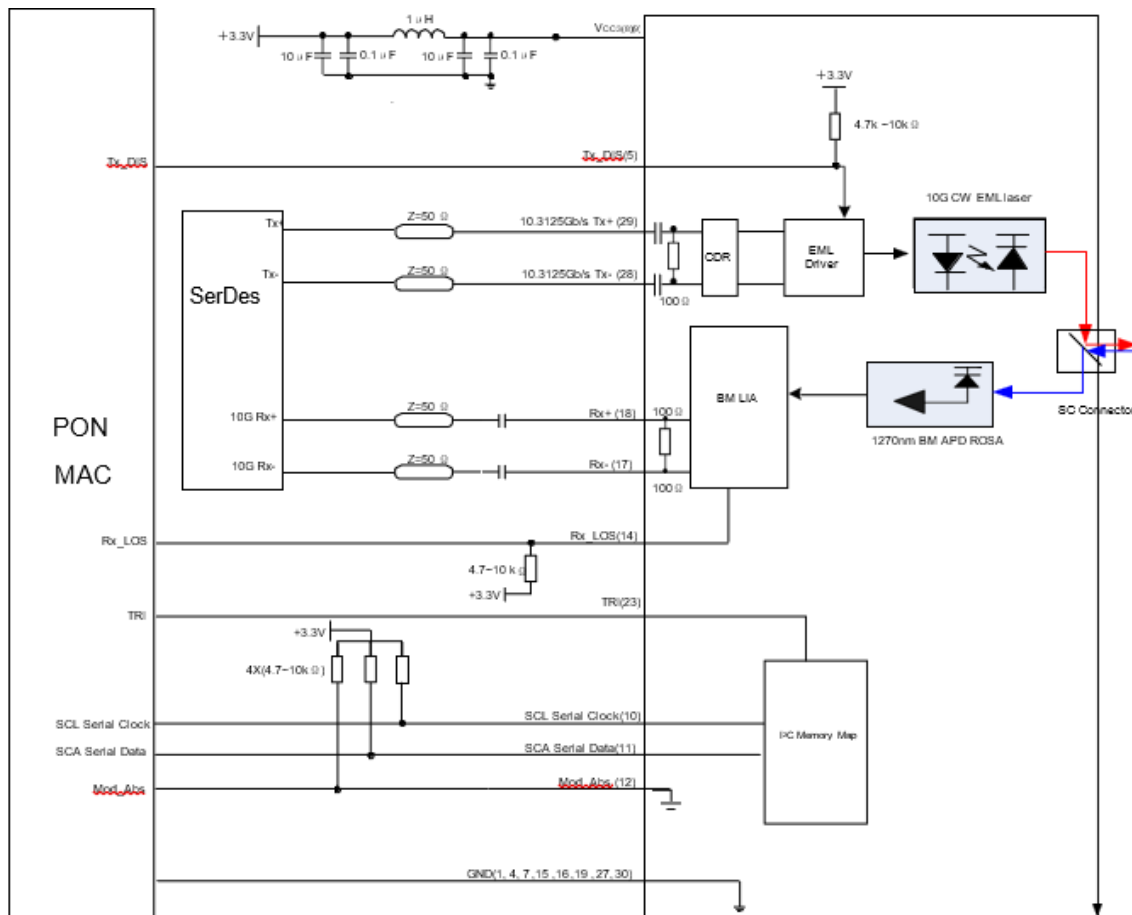

### Digital RSSI Sample/Hold Timing

Parameter	Symbol	Min.	Max.	Unit
Operating Case Temperature	Tc	-40	85	°C
Storage Temperature	Tstg	-40	85	
Relative Storage Humidity	RHstg	0	95	%
Relative Operating Humidity	RHo	0	85	%
Module Supply Voltage	Vcc	0	3.6	V

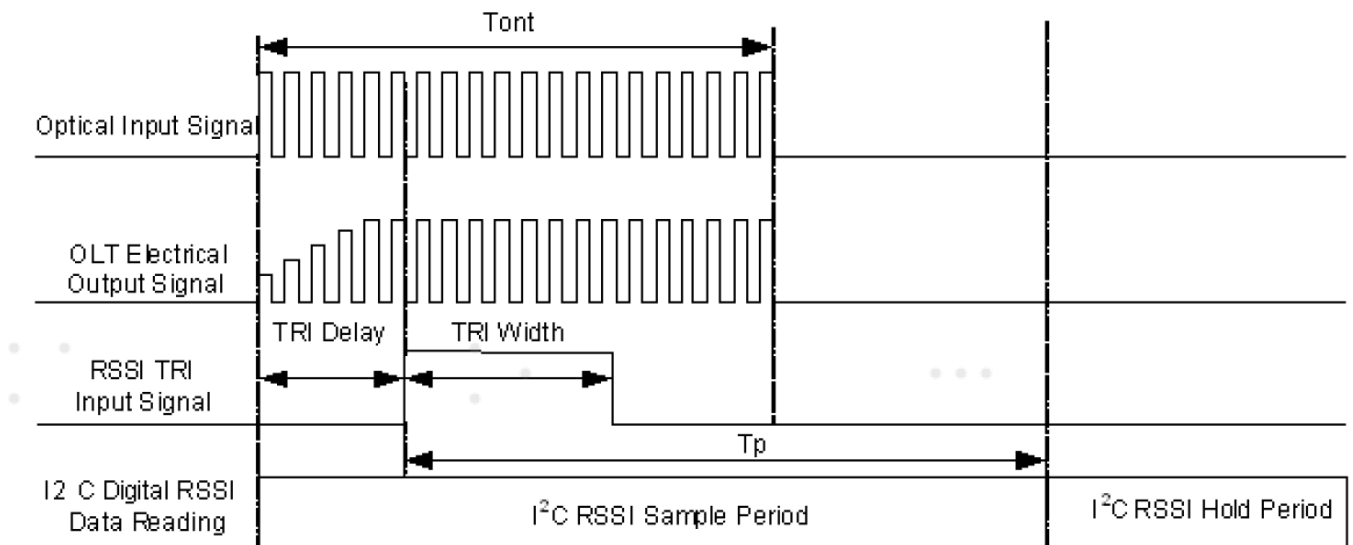

## Mechanical Specifications

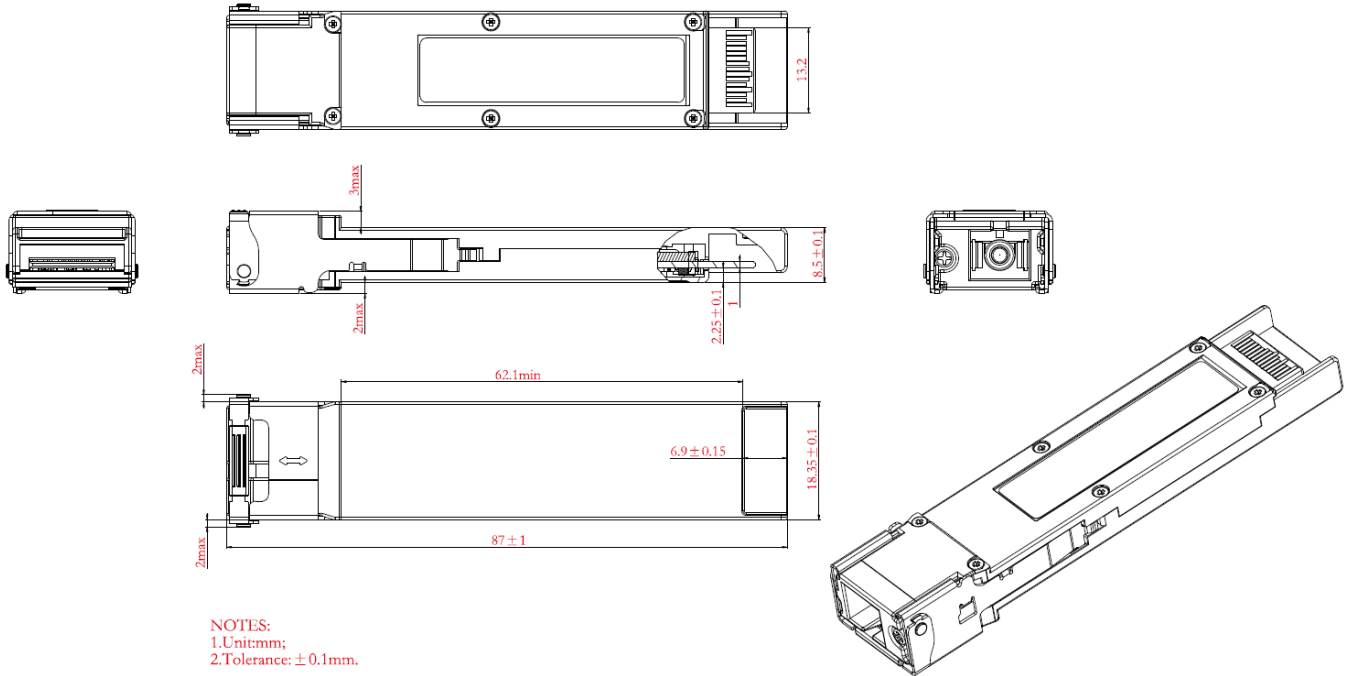

## XFP Connector Dimensions

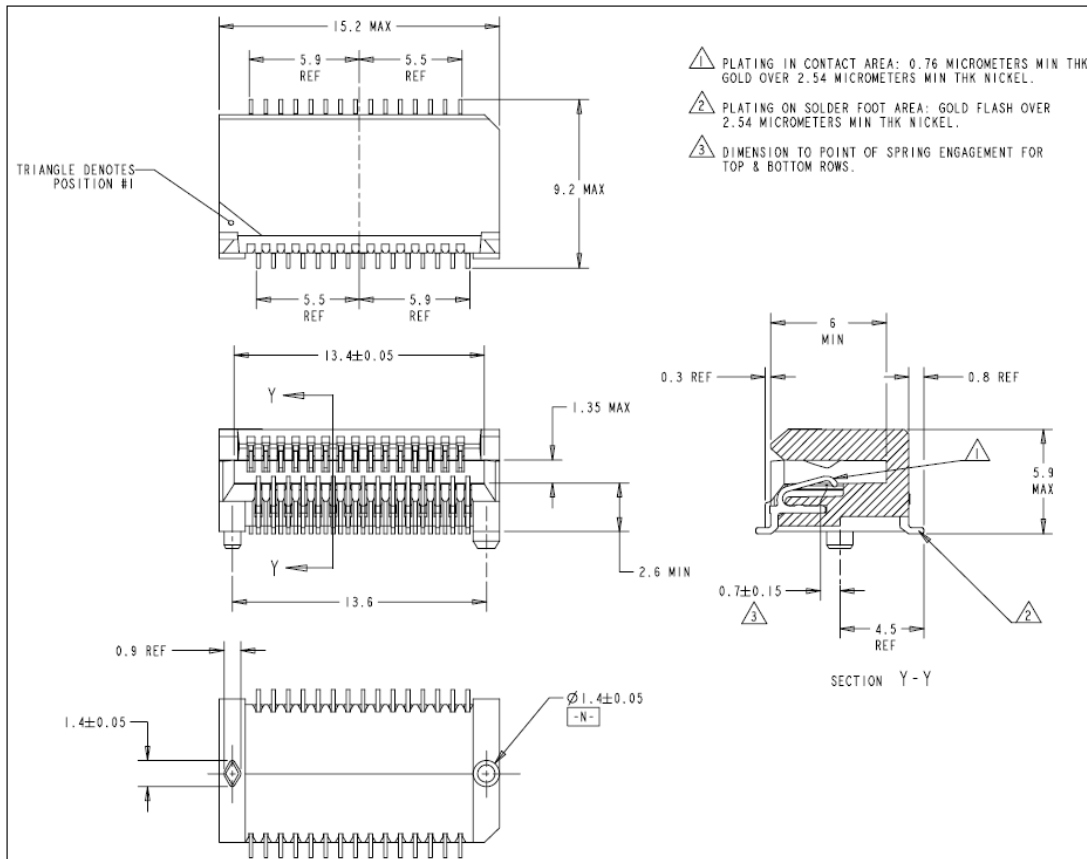

## About ProLabs

Our extensive experience comes as standard. For over 20 years ProLabs has delivered optical connectivity solutions that give our customers freedom and choice through our ability to provide seamless interoperability. At the heart of our company is the ability to provide state-of-the-art optical transport and connectivity solutions that are compatible with more than 100 optical switching and transport platforms.

## A Complete Portfolio of Network Solutions

ProLabs is focused on innovations in optical transport and connectivity. The combination of our knowledge of optics and networking equipment enables ProLabs to be your single source for optical transport and connectivity solutions from 100Mb to 1.6T while providing innovative solutions that increase network efficiency. We provide the optical connectivity expertise that is compatible with and enhances your switching and transport equipment.

## The Trusted Partner

Customer service is our number one value. ProLabs has invested in people, labs and manufacturing capacity to ensure compatible products, and immediate answers to your questions. With Engineering and Manufacturing offices in the U.K. and U.S. augmented by field offices throughout the U.S., U.K. and Asia, ProLabs is able to be our customers best advocate 24 hours a day.



## Contact Information

ProLabs US

Email: [sales@prolabs.com](mailto:sales@prolabs.com)

Telephone: 952-852-0252

ProLabs UK

Email: [salessupport@prolabs.com](mailto:salessupport@prolabs.com)

Telephone: +44 1285 719 600