

## OSFP-QDD-CVR-C

MSA and TAA 800GBase-Converter OSFP-IHS Transceiver (OSFP-IHS to QSFP-DD Converter)

### Features:

- Data Rates: 56Gbps Per Lane or 112Gbps Per Lane
- Compliant with IEEE802.3ck (800GBASE-CR8, 400GBASE-CR4)
- Compliant with IEEE802.3cd (400GBASE-CR8, 200GBASE-CR4)
- Compliant with IEEE802.3bj (200GBASE-CR8, 100GBASE-CR4)
- Connector Compliant with OSFP Octal Small Form Factor Pluggable Module - OSFP MSA and QSFP-DD MSA Standard
- Standard Power Consumption: 16W
- Low-Power Consumption: 0.5W
- Operating Temperature: 0 to 70 Celsius
- RoHS Compliant and Lead-Free



### Applications:

- 800GBase Ethernet

### Product Description

This MSA compliant OSFP to QSFP-DD converter provides conversion from OSFP to QSFP-DD form factors. It is built to MSA standards and is uniquely serialized and data-traffic and application tested to ensure that it will integrate into your network seamlessly. It is built to meet or exceed the specifications of MSA Compliant, as well as to comply with MSA (Multi-Source Agreement) standards to ensure seamless network integration. This converter is Trade Agreements Act (TAA) compliant. We stand behind the quality of our products and proudly offer a limited lifetime warranty.

ProLabs' transceivers are RoHS compliant and lead-free.

TAA refers to the Trade Agreements Act (19 U.S.C. & 2501-2581), which is intended to foster fair and open international trade. TAA requires that the U.S. Government may acquire only "U.S.-made or designated country end products.")



## Absolute Maximum Ratings

Parameter	Symbol	Min.	Typ.	Max.	Unit	Notes
Operating Temperature	Tc	0		70	°C	
Storage Temperature	Tstg	0		70	°C	
Relative Humidity (Non-Condensing)	RH			85	%	
Supply Voltage	Vcc	3.15		3.45	V	
Power Consumption	PC			0.5	W	
Characteristic Impedance	Im	90		110	Ω	
Data Rate	DR	25		112	Gbps	

## OSFP Pin Descriptions

Pin	Logic	Symbol	Name/Description	Plug Sequence	Notes
1		GND	Module Ground.	1	1
2	CML-I	Tx2+	Non-Inverted Transmitter Data.	3	
3	CML-I	Tx2-	Inverted Transmitter Data.	3	
4		GND	Module Ground.	1	1
5	CML-I	Tx4+	Non-Inverted Transmitter Data.	3	
6	CML-I	Tx4-	Inverted Transmitter Data.	3	
7		GND	Module Ground.	1	1
8	CML-I	Tx6+	Non-Inverted Transmitter Data.	3	
9	CML-I	Tx6-	Inverted Transmitter Data.	3	
10		GND	Module Ground.	1	1
11	CML-I	Tx8+	Non-Inverted Transmitter Data.	3	
12	CML-I	Tx8-	Inverted Transmitter Data.	3	
13		GND	Module Ground.	1	1
14	LVC MOS-I/O	SCL	2-Wire Serial Interface Clock.	3	2
15		Vcc	+3.3V Power.	2	
16		Vcc	+3.3V Power.	2	
17	Multi-Level	LPWn/PRSn	Low-Power Mode/Module Present.	3	
18		GND	Module Ground.	1	1
19	CML-O	Rx7-	Inverted Receiver Data.	3	
20	CML-O	Rx7+	Non-Inverted Receiver Data.	3	
21		GND	Module Ground.	1	1
22	CML-O	Rx5-	Inverted Receiver Data.	3	
23	CML-O	Rx5+	Non-Inverted Receiver Data.	3	
24		GND	Module Ground.	1	1

25	CML-O	Rx3-	Inverted Receiver Data.	3	
26	CML-O	Rx3+	Non-Inverted Receiver Data.	3	
27		GND	Module Ground.	1	1
28	CML-O	Rx1-	Inverted Receiver Data.	3	
29	CML-O	Rx1+	Non-Inverted Receiver Data.	3	
30		GND	Module Ground.	1	1
31		GND	Module Ground.	1	1
32	CML-O	Rx2+	Non-Inverted Receiver Data.	3	
33	CML-O	Rx2-	Inverted Receiver Data.	3	
34		GND	Module Ground.	1	1
35	CML-O	Rx4+	Non-Inverted Receiver Data.	3	
36	CML-O	Rx4-	Inverted Receiver Data.	3	
37		GND	Module Ground.	1	1
38	CML-O	Rx6+	Non-Inverted Receiver Data.	3	
39	CML-O	Rx6-	Inverted Receiver Data.	3	
40		GND	Module Ground.	1	1
41	CML-O	Rx8+	Non-Inverted Receiver Data.	3	
42	CML-O	Rx8-	Inverted Receiver Data.	3	
43		GND	Module Ground.	1	1
44	Multi-Level	INT/RSTn	Module Input/Module Reset.	3	
45		Vcc	+3.3V Power.	2	
46		Vcc	+3.3V Power.	2	
47	LVC MOS-I/O	SCL	2-Wire Serial interface Data.	3	2
48		GND	Module Ground.	1	1
49	CML-I	Tx7-	Inverted Transmitter Data.	3	
50	CML-I	Tx7+	Non-Inverted Transmitter Data.	3	
51		GND	Module Ground.	1	1
52	CML-I	Tx5-	Inverted Transmitter Data.	3	
53	CML-I	Tx5+	Non-Inverted Transmitter Data.	3	
54		GND	Module Ground.	1	1
55	CML-I	Tx3-	Inverted Transmitter Data.	3	
56	CML-I	Tx3+	Non-Inverted Transmitter Data.	3	
57		GND	Module Ground.	1	1
58	CML-I	Tx1-	Inverted Transmitter Data.	3	
59	CML-I	Tx1+	Non-Inverted Transmitter Data.	3	
60		GND	Module Ground.	1	1

**Notes:**

1. OSFP uses common ground (GND) for all signals and supply (power). All are common within the OSFP module, and all module voltages are referenced to this potential unless otherwise noted.
2. Open-drain with pull-up resistor on the host.

**Electrical Pad Layout**

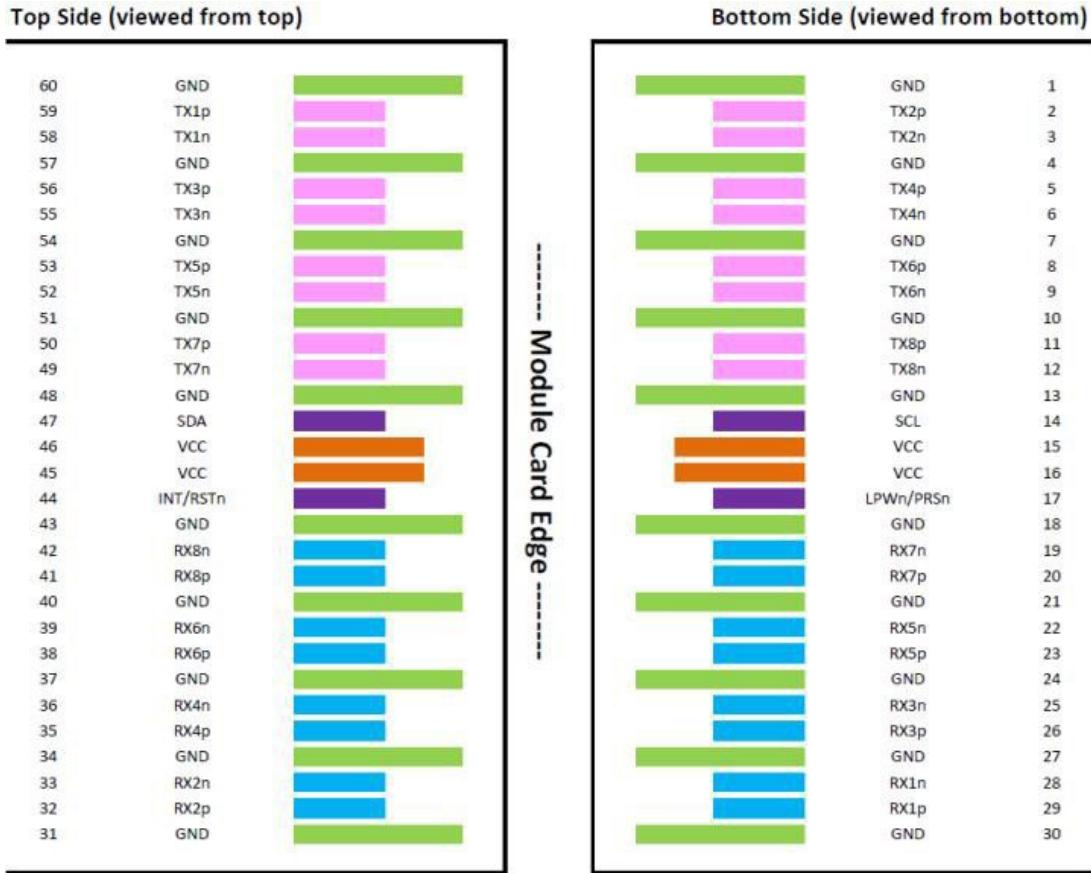

## QSFP-DD Pin Descriptions

Pin	Logic	Symbol	Name/Description		Notes
1		GND	Module Ground.	1B	1
2	CML-I	Tx2-	Inverted Transmitter Data Input.	3B	
3	CML-I	Tx2+	Non-Inverted Transmitter Data Input.	3B	
4		GND	Module Ground.	1B	1
5	CML-I	Tx4-	Inverted Transmitter Data Input.	3B	
6	CML-I	Tx4+	Non-Inverted Transmitter Data Input.	3B	
7		GND	Module Ground.	1B	1
8	LVTTTL-I	ModSelL	Module Select.	3B	
9	LVTTTL-I	ResetL	Module Reset.	3B	
10		VccRx	+3.3V Receiver Power Supply.	2B	2
11	LVC MOS- I/O	SCL	2-Wire Serial Interface Clock.	3B	
12	LVC MOS- I/O	SDA	2-Wire Serial Interface Data.	3B	
13		GND	Module Ground.	1B	1
14	CML-O	Rx3+	Non-Inverted Receiver Data Output.	3B	
15	CML-O	Rx3-	Inverted Receiver Data Output.	3B	
16		GND	Module Ground.	1B	1
17	CML-O	Rx1+	Non-Inverted Receiver Data Output.	3B	
18	CML-O	Rx1-	Inverted Receiver Data Output.	3B	
19		GND	Module Ground.	1B	1
20		GND	Module Ground.	1B	1
21	CML-O	Rx2-	Inverted Receiver Data Output.	3B	
22	CML-O	Rx2+	Non-Inverted Receiver Data Output.	3B	
23		GND	Module Ground.	1B	1
24	CML-O	Rx4-	Inverted Receiver Data Output.	3B	
25	CML-O	Rx4+	Non-Inverted Receiver Data Output.	3B	
26		GND	Module Ground.	1B	1
27	LVTTTL-O	ModPrsL	Module Present.	3B	
28	LVTTTL-O	IntL	Interrupt.	3B	
29		VccTx	+3.3V Transmitter Power Supply.	2B	2
30		Vcc1	+3.3V Power Supply.	2B	2
31	LVTTTL-I	LPMode	Low-Power Mode.	3B	
32		GND	Module Ground.	1B	1
33	CML-I	Tx3+	Non-Inverted Transmitter Data Input.	3B	
34	CML-I	Tx3-	Inverted Transmitter Data Input.	3B	
35		GND	Module Ground.	1B	1
36	CML-I	Tx1+	Non-Inverted Transmitter Data Input.	3B	
37	CML-I	Tx1-	Inverted Transmitter Data Input.	3B	
38		GND	Module Ground.	1B	1
39		GND	Module Ground.	1A	1
40	CML-I	Tx6-	Inverted Transmitter Data Input.	3A	

41	CML-I	Tx6+	Non-Inverted Transmitter Data Input.	3A	
42		GND	Module Ground.	1A	1
43	CML-I	Tx8-	Inverted Transmitter Data Input.	3A	
44	CML-I	Tx8+	Non-Inverted Transmitter Data Input.	3A	
45		GND	Module Ground.	1A	1
46		Reserved	For Future Use.	3A	3
47		VS1	Module Vendor-Specific 1.	3A	3
48		VccRx1	+3.3V Receiver Power Supply.	2A	2
49		VS2	Module Vendor-Specific 2.	3A	3
50		VS3	Module Vendor-Specific 3.	3A	3
51		GND	Module Ground.	1A	1
52	CML-O	Rx7+	Non-Inverted Receiver Data Output.	3A	
53	CML-O	Rx7-	Inverted Receiver Data Output.	3A	
54		GND	Module Ground.	1A	1
55	CML-O	Rx5+	Non-Inverted Receiver Data Output.	3A	
56	CML-O	Rx5-	Inverted Receiver Data Output.	3A	
57		GND	Module Ground.	1A	1
58		GND	Module Ground.	1A	1
59	CML-O	Rx6-	Inverted Receiver Data Output.	3A	
60	CML-O	Rx6+	Non-Inverted Receiver Data Output.	3A	
61		GND	Module Ground.	1A	1
62	CML-O	Rx8-	Inverted Receiver Data Output.	3A	
63	CML-O	Rx8+	Non-Inverted Receiver Data Output.	3A	
64		GND	Module Ground.	1A	1
65		NC	Not Connected.	3A	3
66		Reserved	For Future Use.	3A	3
67		VccTx1	+3.3V Transmitter Power Supply.	2A	2
68		Vcc2	+3.3V Power Supply.	2A	2
69		Reserved	For Future Use.	3A	3
70		GND	Module Ground.	1A	1
71	CML-I	Tx7+	Non-Inverted Transmitter Data Input.	3A	
72	CML-I	Tx7-	Inverted Transmitter Data Input.	3A	
73		GND	Module Ground.	1A	1
74	CML-I	Tx5+	Non-Inverted Transmitter Data Input.	3A	
75	CML-I	Tx5-	Inverted Transmitter Data Input.	3A	
76		GND	Module Ground.	1A	1

**Notes:**

1. QSFP-DD uses common ground (GND) for all signals and supply (power). All are common within the QSFP-DD module, and all module voltages are referenced to this potential unless otherwise noted. Connect these directly to the host board signal common ground plane.
2. VccRx, VccRx1, Vcc1, Vcc2, VccTx, and VccTx1 shall be applied concurrently. VccRx, VccRx1, Vcc1,

Vcc2, VccTx, and VccTx1 may be internally connected within the module in any combination. The connector Vcc pins are each rated for a maximum current of 1000mA.

3. All Vendor-Specific, Reserved, and Not Connected pins may be terminated with 50Ω to ground on the host. Pad 65 (Not Connected) shall be left unconnected within the module. Vendor-Specific and Reserved pads shall have an impedance to GND that is greater than 10kΩ and less than 100pF.
4. Plug Sequence specifies the mating sequence of the host connector and module. The sequence is 1A, 2A, 3A, 1B, 2B, and 3B. Contact sequence A will make, then break, contact with additional QSFP-DD pads. Sequence 1A, 1B will then occur simultaneously, followed by 2A, 2B, followed by 3A, 3B.

### Electrical Pad Layout

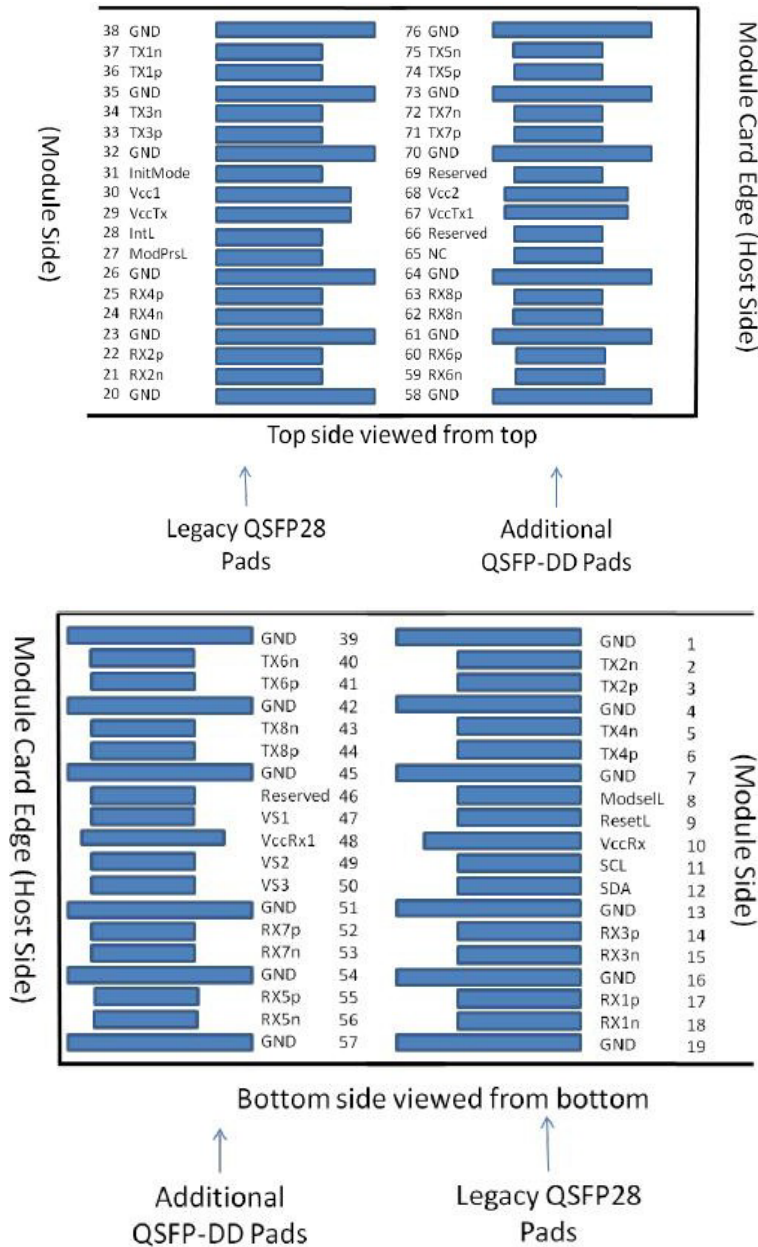

# Mechanical Specifications

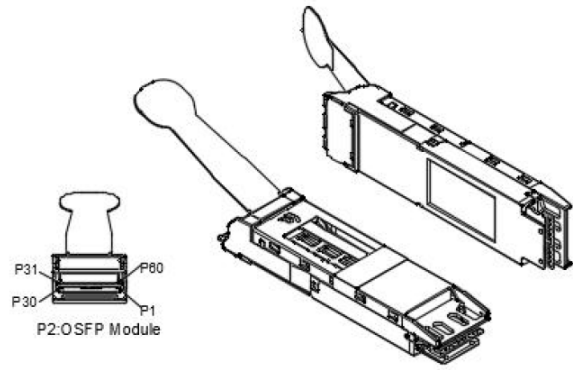
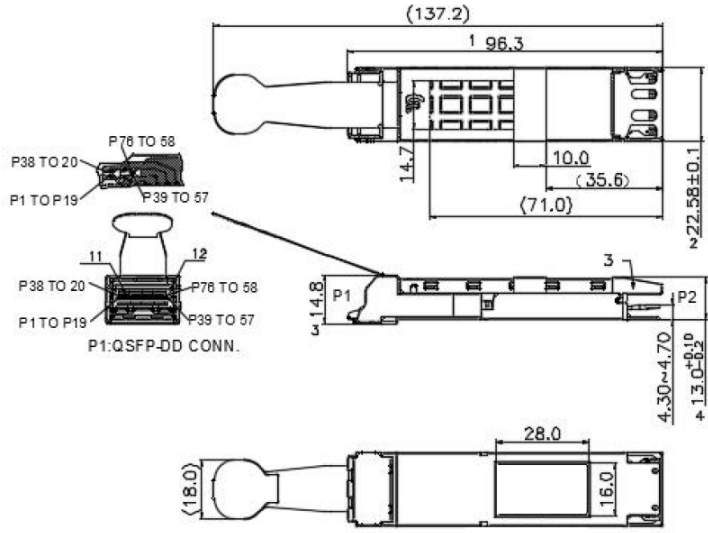

## About ProLabs

Our extensive experience comes as standard. For over 20 years ProLabs has delivered optical connectivity solutions that give our customers freedom and choice through our ability to provide seamless interoperability. At the heart of our company is the ability to provide state-of-the-art optical transport and connectivity solutions that are compatible with more than 100 optical switching and transport platforms.

## A Complete Portfolio of Network Solutions

ProLabs is focused on innovations in optical transport and connectivity. The combination of our knowledge of optics and networking equipment enables ProLabs to be your single source for optical transport and connectivity solutions from 100Mb to 1.6T while providing innovative solutions that increase network efficiency. We provide the optical connectivity expertise that is compatible with and enhances your switching and transport equipment.

## The Trusted Partner

Customer service is our number one value. ProLabs has invested in people, labs and manufacturing capacity to ensure compatible products, and immediate answers to your questions. With Engineering and Manufacturing offices in the U.K. and U.S. augmented by field offices throughout the U.S., U.K. and Asia, ProLabs is able to be our customers best advocate 24 hours a day.



## Contact Information

ProLabs US

Email: [sales@prolabs.com](mailto:sales@prolabs.com)

Telephone: 952-852-0252

ProLabs UK

Email: [salessupport@prolabs.com](mailto:salessupport@prolabs.com)

Telephone: +44 1285 719 600