

SFP-1000BASE-T-I-S-C

MSA and TAA 10/100/1000Base-TX SFP Transceiver (Copper, 100m, RJ-45, -40 to 85C, SGMII)

Features:

- INF-8074 Compliance
- RJ-45 Connector
- Copper Media Type
- Industrial Temperature -40 to 85 Celsius
- Hot Pluggable
- Metal with Lower EMI
- Excellent ESD Protection
- RoHS Compliant and Lead Free



Applications:

- 1000Base Ethernet
- Access and Enterprise

Product Description

This MSA compliant SFP transceiver provides 10/100/1000Base-TX throughput up to 100m over a copper connection via a RJ-45 connector. It can operate at temperatures between -40 and 85C. This TX module supports 10/100/1000Base auto-negotiation and can be configured to fit your needs. It is built to MSA standards and is uniquely serialized and data-traffic and application tested to ensure that they will integrate into your network seamlessly. This transceiver is Trade Agreements Act (TAA) compliant. We stand behind the quality of our products and proudly offer a limited lifetime warranty.

ProLabs' transceivers are RoHS compliant and lead-free.

TAA refers to the Trade Agreements Act (19 U.S.C. & 2501-2581), which is intended to foster fair and open international trade. TAA requires that the U.S. Government may acquire only "U.S.-made or designated country end products.")



Absolute Maximum Ratings

Parameter	Symbol	Min.	Typ.	Max.	Unit	Notes
Data Rate	DR	10		1000	Mb/sec	2
Cable Length	CL			100	m	3
Bit Error Rate	BER			10		
Operating Temperature	TOP	-40		85	°C	4
Storage Temperature	TSTO	-40		85	°C	5
Supply Current	IS		320	375	mA	6
Input Voltage	VCC	3.14	3.3	3.46	V	7
Maximum Voltage	VMAX			4	V	6

Notes:

1. IEEE 802.3 compatible
2. Category 5 UTP
3. Case Temperature
4. Ambient Temperature
5. For electrical power interface
6. Referenced to GND. For electrical power interface

Electrical Characteristics

Parameter	Symbol	Min.	Typ.	Max.	Unit	Notes	
High Speed Electrical Interface Host-SFP							
Single ended Input Swing	V _{IN}	250		1200	mV	1	
Single ended output Swing	V _{OUT}	275		800	mV	1	
Rise time (20%-80%)	T _R		175		ps		
Fall Time (20%-80%)	T _F		175		ps		
Tx Input Impedance	Z _{IN}		50		ohm	1	
Rx Output Impedance	Z _{OUT}		50		ohm	1	
High Speed Electrical Interface Transmission Line-SFP							
Line Frequency	FL		125		MHz	2	
Tx Output Impedance Differential	Z _{OUT_TX}		100		Ohm	3	
Rx Input Impedance Differential	Z _{IN_RX}		100		Ohm	3	
Low Speed Electrical Signal							
SFP Output	Low	V _{OL}	0		0.5	V	4
	High	V _{OH}	Host_Vcc -0.5		Host_Vcc +0.3	V	4
SFP Input	Low	V _{IL}	0		0.8	V	4
	High	V _{IH}	2		VCC + 0.3	V	4

Notes:

1. Single ended
2. 5-level encoding
3. For all frequencies between 1MHz and 125MHz
4. External 4.7-10k ohm pull-up resistor required

Pin Descriptions

Pin	Symbol	Name/Descriptions	Ref.
1	VEET	Transmitter ground (common with receiver ground)	1
2	TX_FAULT	Transmitter Fault. Not supported	
3	TX_DISABLE	Transmitter Disable. PHY disabled on high or open	2
4	MOD_DEF (2)	Module Definition 2. Data line for serial ID	3
5	MOD_DEF (1)	Module Definition 1. Clock line for serial ID	3
6	MOD_DEF (0)	Module Definition 0. Grounded within the module	3
7	Rate Select	No connection required	
8	RX_LOS	Loss of Signal	
9	VEER	Receiver ground (common with transmitter ground)	1
10	VEER	Receiver ground (common with transmitter ground)	1
11	VEER	Receiver ground (common with transmitter ground)	1
12	RD-	Receiver Inverted DATA out. AC coupled	
13	RD+	Receiver Non-inverted DATA out. AC coupled	
14	VEER	Receiver ground (common with transmitter ground)	1
15	VCCR	Receiver power supply	
16	VCCT	Transmitter power supply	
17	VEET	Transmitter ground (common with receiver ground)	1
18	TD+	Transmitter Non-Inverted DATA in. AC coupled	
19	TD-	Transmitter Inverted DATA in. AC coupled	
20	VEET	Transmitter ground (common with receiver ground)	1

Notes:

1. Circuit ground is connected to chassis ground
2. Disabled: TX_DISABLE > 2V or open, Enabled: TX_DISABLE < 0.8V
3. Should be pulled up with 4.7k-10k ohm on host board to a voltage between 2V and 3.6V

Electrical Pad Layout

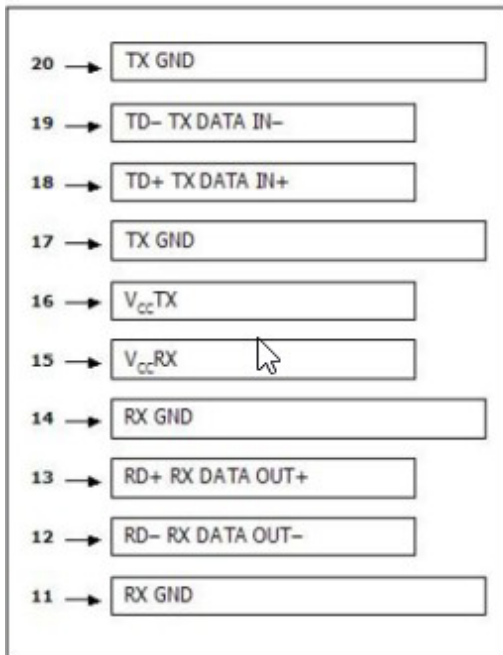
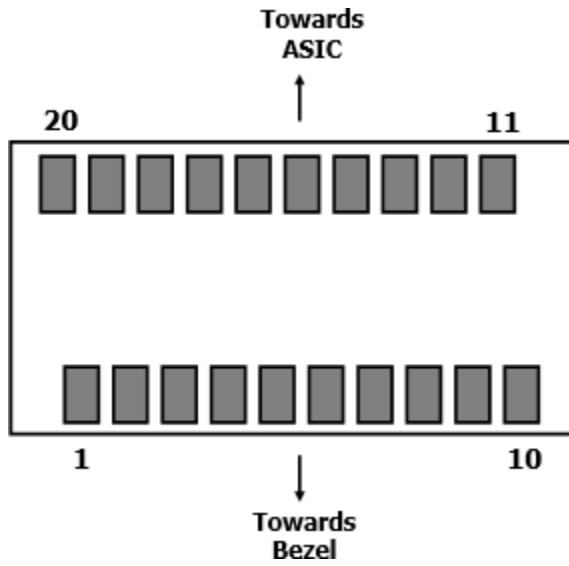

Top of Board

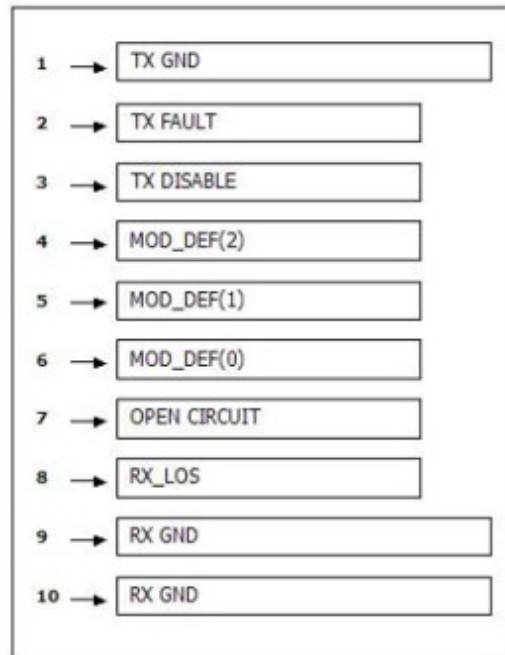

Bottom of Board

Mechanical Specifications

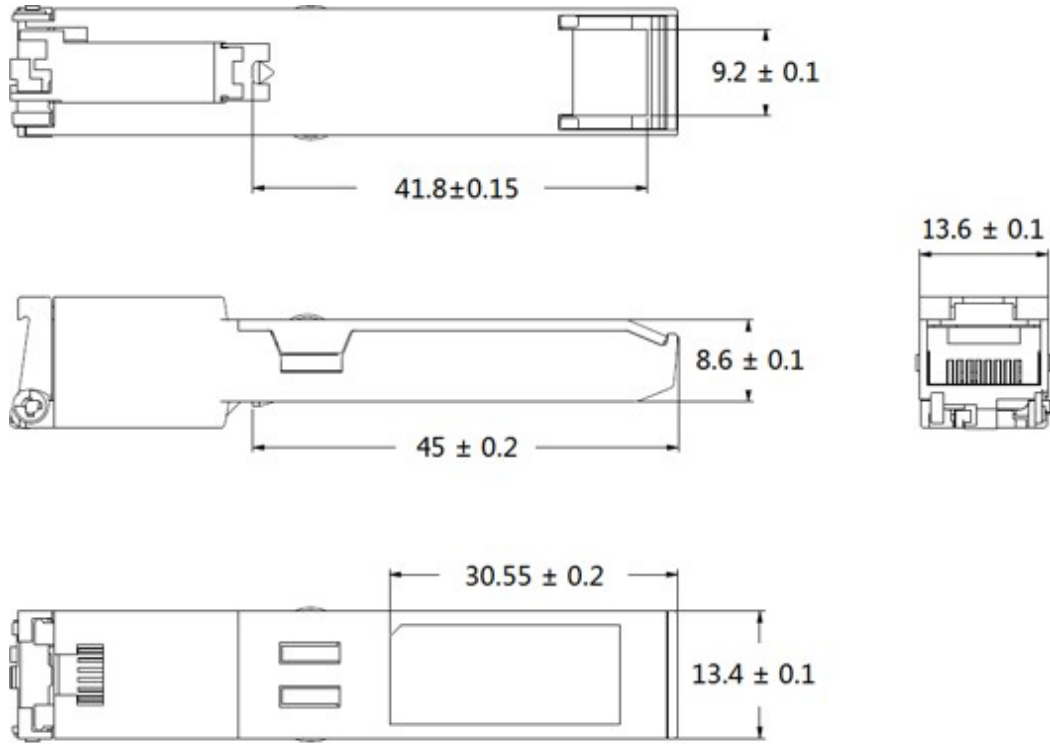

UNIT: mm

About ProLabs

Our extensive experience comes as standard. For over 20 years ProLabs has delivered optical connectivity solutions that give our customers freedom and choice through our ability to provide seamless interoperability. At the heart of our company is the ability to provide state-of-the-art optical transport and connectivity solutions that are compatible with more than 100 optical switching and transport platforms.

A Complete Portfolio of Network Solutions

ProLabs is focused on innovations in optical transport and connectivity. The combination of our knowledge of optics and networking equipment enables ProLabs to be your single source for optical transport and connectivity solutions from 100Mb to 1.6T while providing innovative solutions that increase network efficiency. We provide the optical connectivity expertise that is compatible with and enhances your switching and transport equipment.

The Trusted Partner

Customer service is our number one value. ProLabs has invested in people, labs and manufacturing capacity to ensure compatible products, and immediate answers to your questions. With Engineering and Manufacturing offices in the U.K. and U.S. augmented by field offices throughout the U.S., U.K. and Asia, ProLabs is able to be our customers best advocate 24 hours a day.



Contact Information

ProLabs US

Email: sales@prolabs.com

Telephone: 952-852-0252

ProLabs UK

Email: salessupport@prolabs.com

Telephone: +44 1285 719 600