

SFP-2-5GBASE-MX-I-C

MSA and TAA 2.5GBase-MX SFP Transceiver (MMF, 1310nm, 2km, LC, DOM, -40 to 85C)

Features:

- INF-8074 and SFF-8472 Compliance
- Duplex LC Connector
- Single-mode Fiber
- Industrial Temperature -40 to 85 Celsius
- Hot Pluggable
- Metal with Lower EMI
- Excellent ESD Protection
- RoHS Compliant and Lead Free



Applications:

- 2.5GBase Ethernet
- Up to 2km over MMF
- Access and Enterprise

Product Description

This MSA compliant SFP transceiver provides 2.5GBase-MX throughput up to 2km over multi-mode fiber (MMF) using a wavelength of 1310nm via an LC connector. It can operate at temperatures between -40 and 85C. It is built to MSA standards and is uniquely serialized and data-traffic and application tested to ensure that they will integrate into your network seamlessly. Digital optical monitoring (DOM) support is also present to allow access to real-time operating parameters. This transceiver is Trade Agreements Act (TAA) compliant. We stand behind the quality of our products and proudly offer a limited lifetime warranty.

ProLabs' transceivers are RoHS compliant and lead-free.

TAA refers to the Trade Agreements Act (19 U.S.C. & 2501-2581), which is intended to foster fair and open international trade. TAA requires that the U.S. Government may acquire only "U.S.-made or designated country end products.")



Absolute Maximum Ratings

Parameter	Symbol	Min.	Typ.	Max.	Unit	Notes
Maximum Supply Voltage	Vcc	-0.5		4.0	V	
Storage Temperature	Tstg	-40		85	°C	
Operating Case Temperature	Tc	-40	25	85	°C	
Relative Humidity	RH	5		95	%	
Data Rate			2.488		Gbps	
Power Supply Current	Icc			300	mA	

Electrical Characteristics

Parameter	Symbol	Min.	Typ.	Max.	Unit	Notes
Supply Voltage	Vcc	3.15	3.3	3.45	V	
Data Rate			2.488		Gbps	
9µm Core Diameter SMF	L		15		km	
Transmitter						
LVPECL Inputs (Differential)	Vin	400		1600	mVp-p	1
Input Differential Impedance	Zin	85	100	115	Ω	2
Tx_Dis	Disable	2		Vcc+0.3	V	
	Enable	0		0.8	V	
Tx_Fault	Fault	2		Vcc+0.3	V	
	Normal	0		0.5	V	
Receiver						
LVPECL Outputs (Differential)	Vout	400	800	1200	mVp-p	3
Output Differential Impedance	Zout	85	100	115	Ω	
Tx_Disable Assert Time	Toff			10	us	
Rx_LOS	Loss of Signal (LOS)	2		Vcc+0.3	V	
	Normal Operation	0		0.8	V	
Mod_Def(0.2)	Voh	2.5			V	4
	Vol	0		0.5	V	

Notes:

1. AC Coupled inputs. LVPECL logic. Internally AC coupling.
2. RIN > 100kΩ @ DC.
3. AC Coupled outputs. LVPECL logic. Internally AC coupling.
4. With Serial ID.

Optical Characteristics

Parameter	Symbol	Min.	Typ.	Max.	Unit	Notes
Transmitter						
Center Wavelength	λ_c	1260	1310	1360	nm	
Spectral Width (-20dB)	$\Delta\lambda$			1	nm	
Side Mode Suppression Ratio	SMSR	30			dB	
Average Output Power	POUT	-5		0	dBm	1
Extinction Ratio	ER	8.2			dB	2
Rise/Fall Time (20%-80%)	T_r/T_f			150	ps	
Total Jitter		TJ		0.07	UI	2
POUT@Tx Disable Asserted	POUT			-45	dBm	
Output Optical Eye	ITU-T G.957 Compliant					
Receiver						
Center Wavelength	λ_c	1260		1600	nm	
Receiver Sensitivity	P_{min}			-18	dBm	3
Receiver Overload	P_{max}	-3			dBm	
LOS De-Assert	LOSD			-19	dBm	
LOS Assert	LOSA	-35			dBm	
LOS Hysteresis		0.5			dB	

Notes:

1. Output power is measured by coupling into a 9/125mm single-mode fiber.
2. Filtered. Measured with a PRBS 2^{23} -1 test pattern @2500Mbps.
3. Minimum average optical power is measured at BER less than $1E^{-12}$ with 2^{23} -1 PRBS and ER-9dB.

Pin Descriptions

Pin	Symbol	Name/Descriptions	Plug Seq.	Ref.
1	VeeT	Transmitter Ground.	1	5
2	Tx_Fault	Transmitter Fault Indication.	3	1
3	Tx_Disable	Transmitter Disable. Module disables on “high” or “open.”	3	2
4	MOD-DEF2	Module Definition 2. 2-Wire Serial ID Interface.	3	3
5	MOD-DEF1	Module Definition 1. 2-Wire Serial ID Interface.	3	3
6	MOD-DEF0	Module Definition 0. 2-Wire Serial ID Interface.	3	3
7	Rate Select	Not Connected.	3	Function not available
8	LOS	Loss of Signal.	3	4
9	VeeR	Receiver Ground.	1	5
10	VeeR	Receiver Ground.	1	5
11	VeeR	Receiver Ground.	1	5
12	RD-	Inverse Received Data out.	3	6
13	RD+	Received Data out.	3	7
14	VeeR	Receiver Ground.	1	5
15	VccR	3.3 ± 5% Receiver Power.	2	7
16	VccT	3.3 ± 5% Transmitter Power.	2	7
17	VeeT	Transmitter Ground.	1	5
18	TD+	Transmitter Data In.	3	8
19	TD-	Inverse Transmitter Data In.	3	8
20	VeeT	Transmitter Ground.	1	5

Notes:

- TX Fault is an open collector/drain output, which should be pulled up with a 4.7kΩ–10kΩ resistor on the host board. Pull up voltage between 2.0V and VccT/ R+0.3V. When “high,” output indicates a laser fault of some kind. “Low” indicates normal operation. In the low state, the output will be pulled to < 0.8V.
- Tx_Disable is an input that is used to shut down the transmitter optical output. It is pulled up within the module with a 4.7kΩ–10kΩ resistor. Its states are:
 - Low (0 – 0.8V): Transmitter On (>0.8, < 2.0V): Undefined.
 - High (2.0 – 3.465V): Transmitter Disabled Open: Transmitter Disabled.
- MOD-DEF0,1,2. These are the module definition pins. They should be pulled up with a 4.7kΩ–10kΩ resistor on the host board. The pull-up voltage shall be VccT or VccR.
 - MOD-DEF 0 is grounded by the module to indicate that the module is present.
 - MOD-DEF 1 is the clock line of 2-wire serial interface for serial ID.
 - MOD-DEF 2 is the data line of 2-wire serial interface for serial ID.
- LOS (Loss of Signal) is an open collector/drain output, which should be pulled up with a 4.7kΩ–10kΩ

resistor. Pull up voltage between 2.0V and $V_{ccT}/R+0.3V$. When “high,” this output indicates the received optical power is below the worst-case receiver sensitivity (as defined by the standard in use). “Low” indicates normal operation. In the “low” state, the output will be pulled to $<0.8V$.

5. VeeR and VeeT may be internally connected within the SFP module.
6. RD-/+ : these are the differential receiver outputs. They are AC coupled 100 (differential) lines which should be terminated with 100 (differential) at the user SERDES. The AC coupling is done inside the module and is thus not required on the host board. The voltage swing on these lines will be between 400mV and 2000mV differential (200mV –1000mV single ended) when properly terminated.
7. VccR and VccT are the receiver and transmitter power supplies. They are defined as $3.3V\pm5\%$ at the SFP connector pin. Maximum supply current is 300mA. Recommended host board power supply filtering is shown below. Inductors with DC resistance of less than 1Ω should be used in order to maintain the required voltage at the SFP input pin with 3.3V supply voltage. When the recommended supply-filtering network is used, hot-plugging of the SFP transceiver module will result in an inrush current of no more than 30mA greater than the steady state value. VccR and VccT may be internally connected within the SFP transceiver module.
8. TD-/+ : these are the differential transmitter inputs. They are AC-coupled, differential lines with 100 differential terminations inside the module. The AC coupling is done inside the module and is thus not required on the host board. The inputs will accept differential swings of 400mV - 2000mV (200mV – 1000mV single-ended).

Electrical Pin-out Details

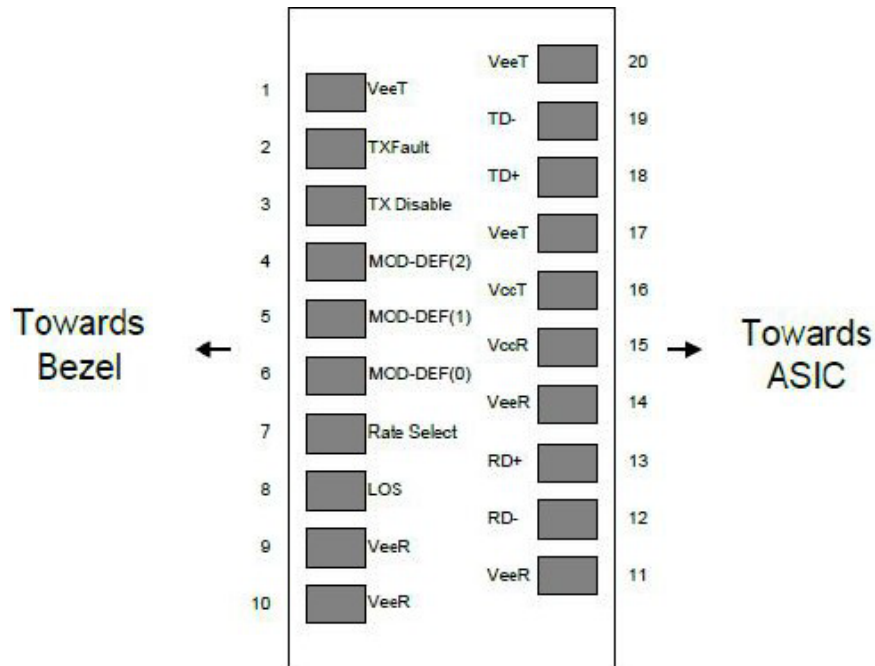

Recommended Application Interface Block Diagram

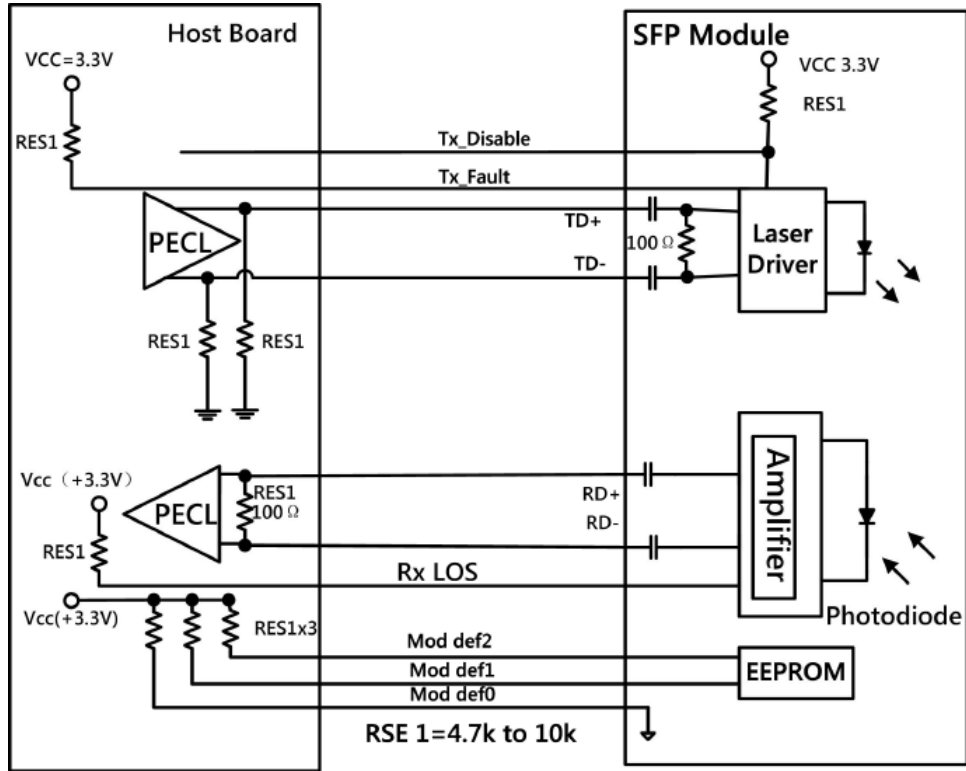

Mechanical Specifications

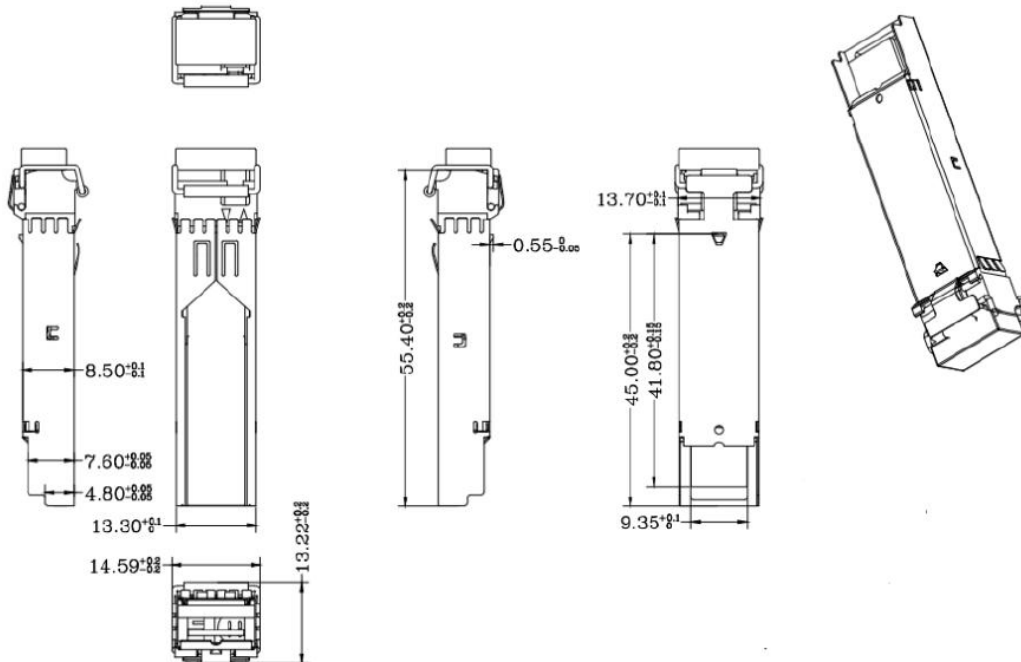

About ProLabs

Our extensive experience comes as standard. For over 20 years ProLabs has delivered optical connectivity solutions that give our customers freedom and choice through our ability to provide seamless interoperability. At the heart of our company is the ability to provide state-of-the-art optical transport and connectivity solutions that are compatible with more than 100 optical switching and transport platforms.

A Complete Portfolio of Network Solutions

ProLabs is focused on innovations in optical transport and connectivity. The combination of our knowledge of optics and networking equipment enables ProLabs to be your single source for optical transport and connectivity solutions from 100Mb to 1.6T while providing innovative solutions that increase network efficiency. We provide the optical connectivity expertise that is compatible with and enhances your switching and transport equipment.

The Trusted Partner

Customer service is our number one value. ProLabs has invested in people, labs and manufacturing capacity to ensure compatible products, and immediate answers to your questions. With Engineering and Manufacturing offices in the U.K. and U.S. augmented by field offices throughout the U.S., U.K. and Asia, ProLabs is able to be our customers best advocate 24 hours a day.



Contact Information

ProLabs US

Email: sales@prolabs.com

Telephone: 952-852-0252

ProLabs UK

Email: salessupport@prolabs.com

Telephone: +44 1285 719 600