

SFP-10GB-BXU34-10-C

MSA and TAA 10GBase-BX SFP+ Transceiver (SMF, 1310nmTx/1490nmRx, 10km, LC, DOM)

Features:

- Operating Data Rate up to 10.31Gbps
- Single 3.3V Power Supply
- Hot-Pluggable SFP+
- 10km with 9/125µm SMF
- Compliant with MSA SFP+ Specification
- Simplex LC Connector
- Power Consumption: 1.5W
- Operating Temperature: 0 to 70 Celsius
- RoHS Compliant and Lead-Free



Applications:

- 10GBase-BX Ethernet
- 8x/10x Fibre Channel
- Access, Metro and Enterprise

Product Description

This MSA compliant SFP+ transceiver provides 10GBase-BX throughput up to 10km over single-mode fiber (SMF) using a wavelength of 1310nmTx/1490nmRx via an LC connector. This bidirectional unit must be used with another transceiver or network appliance of complementing wavelengths. It can operate at temperatures between 0 and 70C. All of our transceivers are built to comply with Multi-Source Agreement (MSA) standards and are uniquely serialized and tested for data-traffic and application to ensure seamless network integration. Additional product features include Digital Optical Monitoring (DOM) support which allows access to real-time operating parameters. This transceiver is Trade Agreements Act (TAA) compliant. We stand behind the quality of our products and proudly offer a limited lifetime warranty.

ProLabs' transceivers are RoHS compliant and lead-free.

TAA refers to the Trade Agreements Act (19 U.S.C. & 2501-2581), which is intended to foster fair and open international trade. TAA requires that the U.S. Government may acquire only "U.S.-made or designated country end products.")



Absolute Maximum Ratings

Parameter	Symbol	Min.	Typ.	Max.	Unit	Notes
Operating Case Temperature	Tc	0		70	°C	
Storage Temperature	Tstg	-40		85	°C	
Relative Humidity	RH	5		85	%	
Supply Voltage	Vcc	-0.5		3.6	V	
Data Rate	DR	1.25		10.3125	Gbps	
Power Budget		9			dB	

Electrical Characteristics

Parameter	Symbol	Min.	Typ.	Max.	Unit	Notes
Power Supply Voltage	Vcc	3.13	3.3	3.47	V	
Power Supply Current	Icc			450	mA	
Transmitter						
CML Differential Input	VIN	150		1200	mVp-p	1
Input AC Common-Mode Voltage		0		25	mV	RMS
Input Differential Impedance	ZIN	85	100	115	Ω	2
Tx_Disable	High	2		Vcc	V	
	Low	0		0.8	V	
Tx_Fault	High	2		Vcc+0.3	V	3
	Low	0		0.5	V	4
Receiver						
CML Differential Output	VOUT	350		700	mVp-p	5
Output Differential Impedance	ZOUT	85	100	115	Ω	
Rx_LOS	High	2		Vcc+0.3	V	3
	Low	0		0.8	V	4
MOD_DEF(0.2)	VOH	2.5			V	6
	VOL	0		0.5	V	6

Notes:

1. AC coupled inputs.
2. RIN > 100kΩ @ DC.
3. I_o = 400μA; Host_Vcc
4. I_o = -4.0mA
5. AC coupled outputs.
6. With serial ID.

Optical Characteristics

Parameter	Symbol	Min.	Typ.	Max.	Unit	Notes
Transmitter						
Center Wavelength	λ_C	1300	1310	1320	nm	
Spectral Width (-20dB)	$\Delta\lambda$			1	nm	
Average Output Power	POUT	-5		0	dBm	1
Extinction Ratio	ER	3.5			dB	
Average Power of Off Transmitter	Poff			-30	dBm	
Side-Mode Suppression Ratio	SMSR	30			dB	
Transmitter Dispersion Penalty	TDP			2	dB	
Tx Disable Assert Time	Toff			10	us	
Receiver						
Center Wavelength	λ_C	1480	1490	1580	nm	
Receiver Sensitivity	Pmin			-14	dBm	2
Receiver Overload	Pmax	0.5			dBm	
LOS Assert	LOSA	-30			dBm	
LOS De-Assert	LOSD			-15	dBm	
LOS Hysteresis	LOSH	0.5			dB	

Notes:

1. Output is coupled into a 9/125 μ m SMF.
2. Minimum average optical power is measured at BER less than $1E^{-12}$. The measure pattern is PRBS2³¹-1.

Pin Descriptions

Pin	Symbol	Name/Description	Plug Seq.	Notes
1	VeeT	Transmitter Ground.	1	5
2	Tx_Fault	Transmitter Fault Indication.	3	1
3	Tx_Disable	Transmitter Disable. Module disables on “high” or “open.”	3	2
4	SDA	Transmitter Disable. 2-Wire Serial ID Interface.	3	3
5	SCL	Module Definition 2. 2-Wire Serial ID Interface.	3	3
6	MOD_ABS	Module Definition 1. Grounded within the module.	3	3
7	RS0	Rx Rate Select (LVTTTL). No User Connection. Pin Not Used.	3	
8	LOS	Loss of Signal.	3	4
9	RS0	Tx Rate Select (LVTTTL). No User Connection. Pin Not Used.	1	
10	VeeR	Receiver Ground.	1	5
11	VeeR	Receiver Ground.	1	5
12	RD-	Receiver Inverse Data Out.	3	6
13	RD+	Receiver Data Out.	3	6
14	VeeR	Receiver Ground.	1	5
15	VccR	3.3 ± 5% Receiver Power.	2	7
16	VccT	3.3 ± 5% Transmitter Power.	2	7
17	VeeT	Transmitter Ground.	1	5
18	TD+	Transmitter Data In.	3	8
19	TD-	Transmitter Inverse Data In.	3	8
20	VeeT	Transmitter Ground.	1	5

Notes:

1. Tx_Fault is an open collector/drain output that should be pulled up with a 4.7kΩ to 10kΩ resistor on the host board. When “high,” output indicates a laser fault of some kind. “Low” indicates normal operation. In the “low” state, the output will be pulled to <0.8V.
2. Tx_Disable is an input that is used to shut down the transmitter optical output. It is pulled up within the module with a 4.7kΩ to 10kΩ resistor. Its states are:
 - Low (0V – 0.8V): Transmitter On
 - (>0.8V, <2.0V): Undefined
 - High (2.0V – 3.465V): Transmitter Disabled
 - Open: Transmitter Disabled.
3. Modulation absent. Connected to VeeT or VeeR in the module.
4. LOS (Loss of Signal) is an open collector/drain output that should be pulled up with a 4.7kΩ to 10kΩ resistor. When “high,” this output indicates that the received optical power is below the worst-case receiver sensitivity (as defined by the standard in use). “Low” indicates normal operation. In the “low” state, the output will be pulled to <0.8V.
5. VeeR and VeeT may be internally connected within the SFP module.

6. RD-/+. These are the differential receiver outputs. They are AC-coupled, 100Ω differential lines that should be terminated with 100Ω (differential) at the user SERDES.
7. VccR and VccT are the receiver and transmitter power supplies. They are defined as 3.3V ± 5% at the SFP connector pin.
8. TD-/+. These are the differential transmitter inputs. They are AC-coupled, differential lines with 100Ω differential termination inside the module.

Electrical Pad Layout

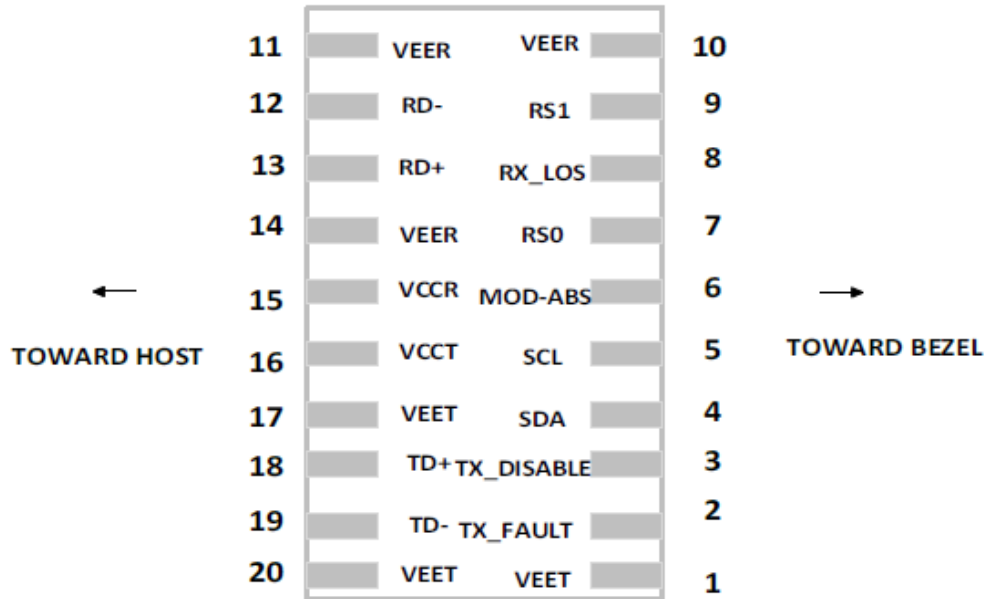

Recommended Circuit Schematic

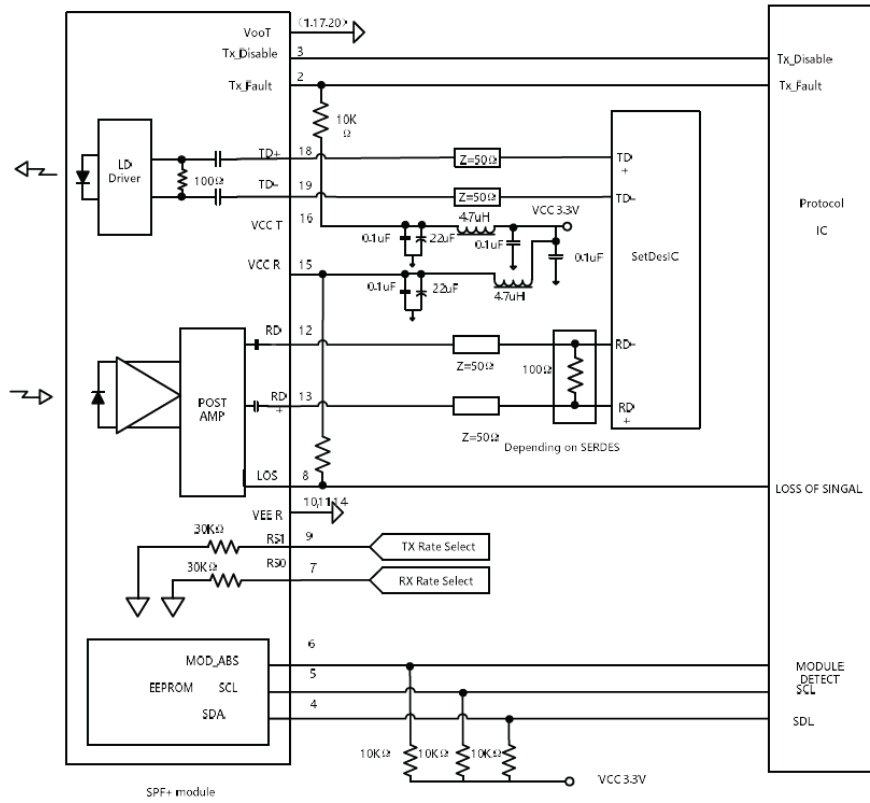

Mechanical Specifications

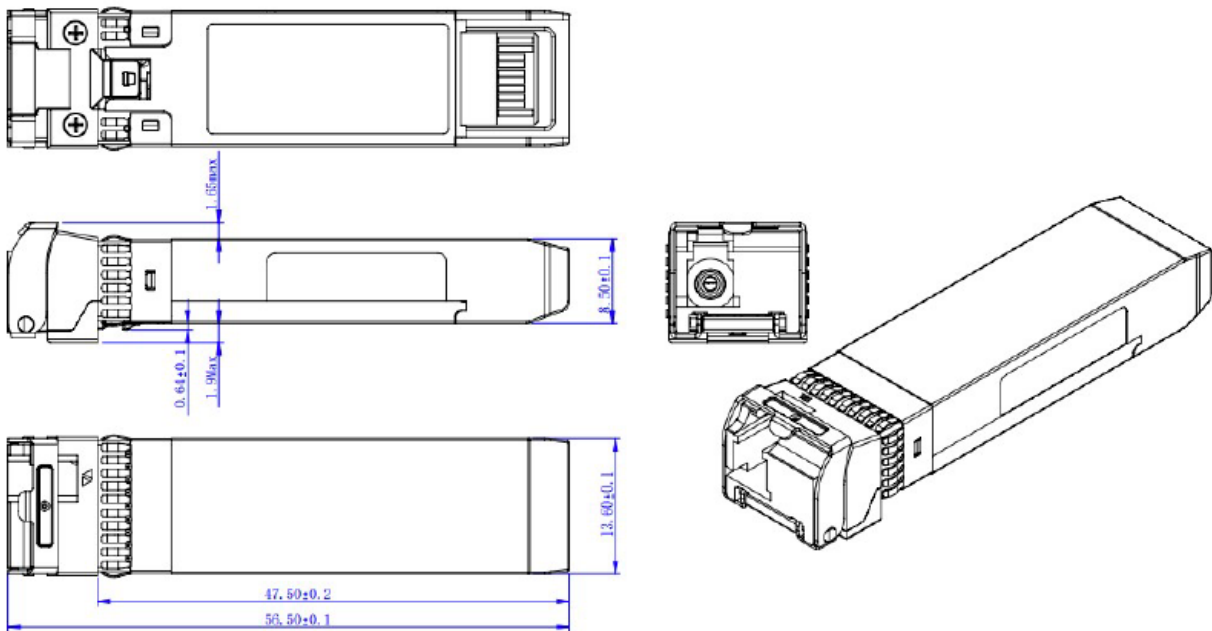

About ProLabs

Our extensive experience comes as standard. For over 20 years ProLabs has delivered optical connectivity solutions that give our customers freedom and choice through our ability to provide seamless interoperability. At the heart of our company is the ability to provide state-of-the-art optical transport and connectivity solutions that are compatible with more than 100 optical switching and transport platforms.

A Complete Portfolio of Network Solutions

ProLabs is focused on innovations in optical transport and connectivity. The combination of our knowledge of optics and networking equipment enables ProLabs to be your single source for optical transport and connectivity solutions from 100Mb to 1.6T while providing innovative solutions that increase network efficiency. We provide the optical connectivity expertise that is compatible with and enhances your switching and transport equipment.

The Trusted Partner

Customer service is our number one value. ProLabs has invested in people, labs and manufacturing capacity to ensure compatible products, and immediate answers to your questions. With Engineering and Manufacturing offices in the U.K. and U.S. augmented by field offices throughout the U.S., U.K. and Asia, ProLabs is able to be our customers best advocate 24 hours a day.



Contact Information

ProLabs US

Email: sales@prolabs.com

Telephone: 952-852-0252

ProLabs UK

Email: salessupport@prolabs.com

Telephone: +44 1285 719 600