

### SFP+ XGS-ONU-MAC-I-G2-C

MSA and TAA 9.95Gbs/9.95Gbs XGS PON N1/N2 ONU SFP+ Stick with MAC (SMF, 1270nmTx/1577nmRx, SC, -40 to 85C) Gen 2

#### Features:

- SC/UPC Connector
- 1270nm Burst-Mode Transmitter with DFB Laser
- 1577nm Continuous-Mode Receiver with APD-TIA
- Compliant with ITU-T G.9807.1 XGS-PON N1/N2
- Single 3.3V Power Supply
- Hot-Pluggable
- Operating Temperature: -40 to 85 Celsius
- RoHS Compliant and Lead-Free
- RoHS Compliant and lead-Free



#### Applications:

- XGS PON
- Access and Enterprise

#### Product Description

This MSA compliant SFP+ transceiver provides 9.95Gbs/9.95Gbs XGS-PON throughput up to 20km over single-mode fiber (SMF) using a wavelength of 1270nmTx/1577nmRx via an SC connector. This bidirectional unit must be used with another transceiver or network appliance of complementing wavelengths. This easy to install, hot swappable transceiver has been programmed, uniquely serialized and data-traffic and application tested to ensure that it will initialize and perform identically. Digital optical monitoring (DOM) support is also present to allow access to real-time operating parameters. This transceiver is Trade Agreements Act (TAA) compliant. We stand behind the quality of our products and proudly offer a limited lifetime warranty.

ProLabs' transceivers are RoHS compliant and lead-free.

TAA refers to the Trade Agreements Act (19 U.S.C. & 2501-2581), which is intended to foster fair and open international trade. TAA requires that the U.S. Government may acquire only "U.S.-made or designated country end products."



## Absolute Maximum Ratings

Parameter	Symbol	Min.	Typ.	Max.	Unit	Notes
Relative Humidity (Non-Condensing)	%	5		85	%	
Operating Case Temperature	T <sub>c</sub>	-40		85	°C	
Storage Temperature	T <sub>stg</sub>	-40		85	°C	
Supply Voltage	V	0		3.6		
Transmission Distance	TD			20	km	
Data Rate	DR		9.9532 10.3125		Gbps	

## Electrical Characteristics

Parameter	Symbol	Min.	Typ.	Max.	Unit	Notes
Power Supply Voltage		3.15	3.3	3.45	V <sub>cc</sub>	
Power Supply Current	I <sub>cc</sub>			600	mA	
Power Consumption				2.0	W	
<b>Transmitter</b>						
Data Differential Input Swing		190		1000	mV <sub>p-p</sub>	
Data Differential Impedance		80	100	120	Ω	
Transmitter Disable Voltage – Low		0		0.8	V	
Transmitter Disable Voltage – High		2.0		V <sub>cc</sub>	V	
Power Down Voltage – Low		0		0.8	V	
Power Down Voltage – High		2.0		V <sub>cc</sub>	V	
Tx_Fault Assert Time				50	ms	
Tx_Fault Reset Time		10			μs	
Burst Turn On Time				51.2	ns	
Burst Turn Off Time				51.2	ns	
Tx Power Down Assert Time				512	ns	1
Tx Power Down De-Assert Time				512	ns	2
<b>Receiver</b>						
Data Output Differential Swing		300		850	mV <sub>p-p</sub>	
Loss of Signal (LOS) Assert Time				100	us	
Loss of Signal (LOS) De-Assert Time				100	us	
Differential Output Impedance		80	100	120	Ω	

### Notes:

1. Measured to 10% of final supply current.
2. Measured to 90% of final supply current.

## Optical Characteristics

Parameter	Symbol	Min.	Typ.	Max.	Unit	Notes
<b>Transmitter</b>						
Optical Center Wavelength	$\lambda_C$	1260	1270	1290	nm	
Spectral Width (-20dB)				1	nm	
Side-Mode Suppression Ratio	SMSR	30			dB	
Average Output Power	AOP	4		9	dBm	
Burst Enable is Off Power	Poff			-45	dBm	
Extinction Ratio	ER	6			dB	1
Optical Eye Mask	Compliant with ITU-T G9807.1					1
<b>Receiver</b>						
Optical Center Wavelength	$\lambda_C$	1575	1577	1580	nm	
Receiver Sensitivity (PRBS $2^{31}-1$ @9.952G, ER 8.2 Tx)				-28.5	dBm	2
Receiver Overload (PRBS $2^{31}-1$ @9.952G, ER 8.2 Tx)		-9			dBm	2
Loss of Signal Assert Level		-39			dBm	
Loss of Signal De-Assert Level				-29	dBm	
Isolation (1550nm-1560nm) into 1577nm Rx		35			dB	
Isolation (1490nm-1500nm GPON) into 1577nm Rx		25			dB	
Isolation (1260nm-1330nm XGS-PON) into 1577nm Rx		31			dB	
Isolation (1524nm-1544nm NGPON2) into 1577nm Rx		27			dB	
Isolation (1596nm-1603nm NGPON2) into 1577nm Rx		31			dB	
Isolation (1603nm-1625nm PtP) into 1577nm Rx		35			dB	
Isolation (1625nm-1650nm) into 1577nm Rx		35			dB	
Isolation (Internal 1260nm-1280nm Tx) into 1577nm Rx		35			dB	

### Notes:

1. Measured with a PRBS  $2^{31}-1$  test pattern @9.9532Gbps.
2. Measured with a PRBS  $2^{31}-1$  test pattern @9.9532Gbps, ER=6dB, and BER $\leq 1.0E^{-3}$ .

## Pin Descriptions

Pin	Symbol	Logic	Name/Description	Notes
1	VeeT		Module Transmitter Ground.	
2	ToD	LVTTTL-O	Time of Day.	1, 5
3	NC	LVTTTL-I	Not Connected.	4
4	SDA	LVTTTL-I/O	2-Wire Serial Interface Data Line.	2
5	SCL	LVTTTL-I	2-Wire Serial Interface Clock Line.	2
6	MOD_ABS	LVTTTL-O	Module Absent. Set to Low.	3
7	Dying_Gasp	LVTTTL-I	Default: Not Used. Dying Gasp Function (Software Option).	5
8	Rx_LOS	LVTTTL-O	Receiver Loss of Signal Indication.	3
9	1PPS	LVTTTL-O	1 Pulse Per Second.	5
10	VeeR		Receiver Ground.	
11	VeeR		Receiver Ground.	
12	RD-	CML-O	Receiver Inverted Data Output.	
13	RD+	CML-O	Receiver Non-Inverted Data Output.	
14	VeeR		Receiver Ground.	
15	VccR		Receiver 3.3V Power Supply.	
16	VccT		Transmitter 3.3V Power Supply.	
17	VeeT		Transmitter Ground.	
18	TD+	CML-I	Transmitter Non-Inverted Data Input.	
19	TD-	CML-I	Transmitter Inverted Data Input.	
20	VeeT		Transmitter Ground.	

### Notes:

1. Output from the MCU\_UART\_TX post.
2. 10kΩ pull-up is applied inside the XGSPON stick.
3. It needs to be pulled up with 4.7kΩ-10kΩ to a Host\_Vcc on the host board.
4. NC pin. It needs to be pulled up or down, or NC on the host board.
5. Software option: ToD/1PPS/Dying Gasp functions disabled by the software. If the ToD, 1PPS, or Dying Gasp function is required, you need to upgrade the software with the function enabled.

## Pin-Out Details

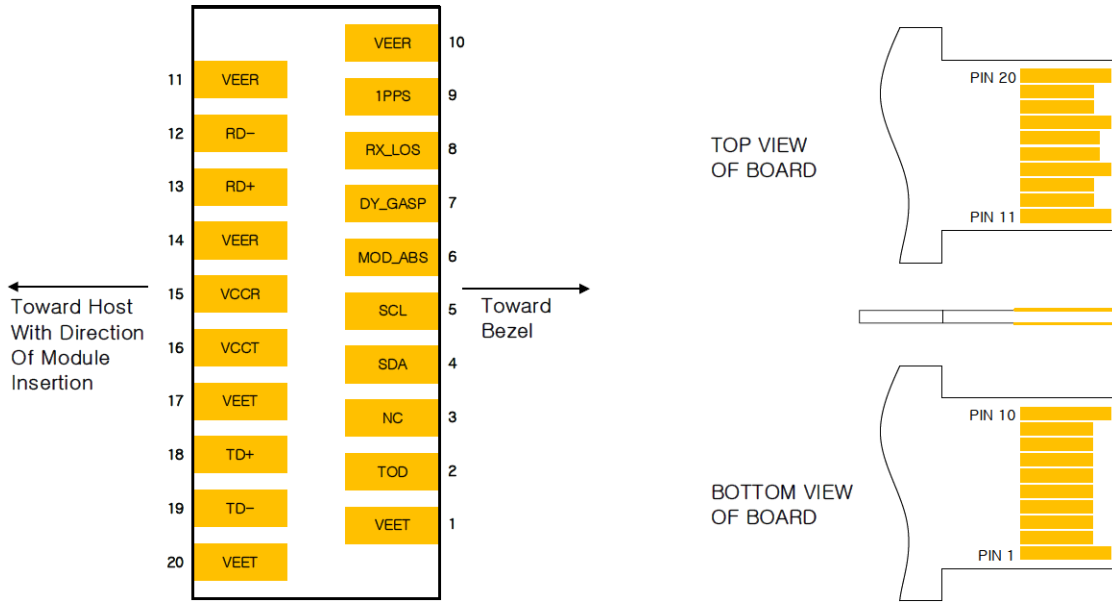

## Block Diagram

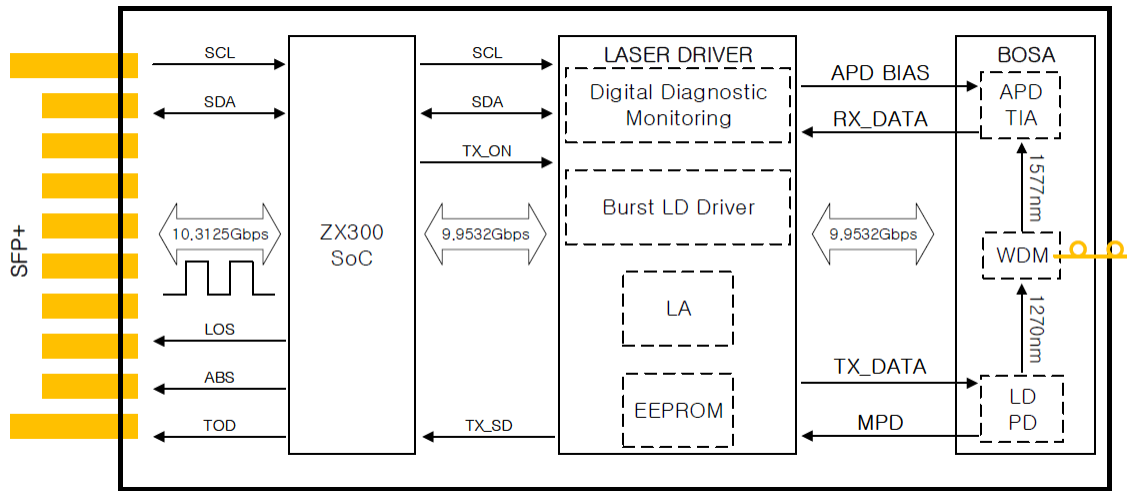

**Mechanical Specifications**

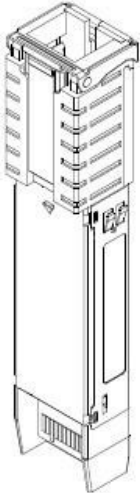
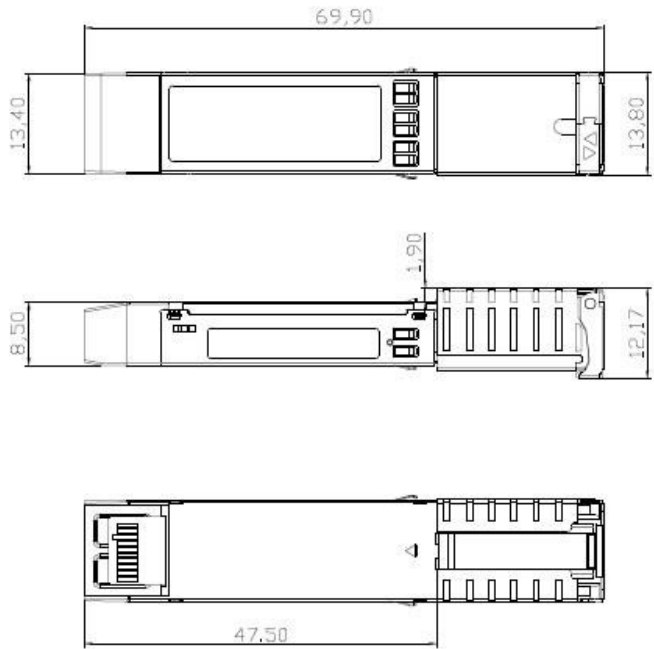

## About ProLabs

Our extensive experience comes as standard. For over 20 years ProLabs has delivered optical connectivity solutions that give our customers freedom and choice through our ability to provide seamless interoperability. At the heart of our company is the ability to provide state-of-the-art optical transport and connectivity solutions that are compatible with more than 100 optical switching and transport platforms.

## A Complete Portfolio of Network Solutions

ProLabs is focused on innovations in optical transport and connectivity. The combination of our knowledge of optics and networking equipment enables ProLabs to be your single source for optical transport and connectivity solutions from 100Mb to 1.6T while providing innovative solutions that increase network efficiency. We provide the optical connectivity expertise that is compatible with and enhances your switching and transport equipment.

## The Trusted Partner

Customer service is our number one value. ProLabs has invested in people, labs and manufacturing capacity to ensure compatible products, and immediate answers to your questions. With Engineering and Manufacturing offices in the U.K. and U.S. augmented by field offices throughout the U.S., U.K. and Asia, ProLabs is able to be our customers best advocate 24 hours a day.



## Contact Information

ProLabs US

Email: [sales@prolabs.com](mailto:sales@prolabs.com)

Telephone: 952-852-0252

ProLabs UK

Email: [salessupport@prolabs.com](mailto:salessupport@prolabs.com)

Telephone: +44 1285 719 600