

SFP-1/10GB-BXD5332-20-AO

MSA and TAA 1/10GBase-BX SFP+ Transceiver (SMF,1550nmTx/1310nmRx at 1G, 1330nmTx/1270nmRx at 10G, 20km, LC, DOM)

Features

- Single Fiber Bi-Directional Data Links Up to 20km with SMF
- Simplex LC Connector
- Selectable 10G and 1G Mode by Hardware or Software
- 1.25G: TX 1550nm DFB LD & RX 1310nm PIN PD
- Single 3.3V Power Supply
- 10G: TX 1330nm DFB LD & RX 1270nm PIN PD
- Low-Power Dissipation: 1W
- CML-Compatible Data Input & Output Interfaces
- RoHS Compliant and Lead-Free
- Operating Temperature: 0 to 70 Celsius



Applications

- 1/10-Gbase Ethernet

Product Description

This MSA compliant SFP+ transceiver provides 1/10GBase-BX throughput up to 20km over single-mode fiber (SMF) using a wavelength of 1550nmRx/1310nmTx at 1G and 1330nmTx/1270nmRx at 10G via an LC connector. This bidirectional unit must be used with another transceiver or network appliance of complementing wavelengths. This easy to install, hot swappable transceiver has been programmed, uniquely serialized and data-traffic and application tested to ensure that it will initialize and perform identically. Digital optical monitoring (DOM) support is also present to allow access to real-time operating parameters. This transceiver is Trade Agreements Act (TAA) compliant. We stand behind the quality of our products and proudly offer a limited lifetime warranty.

AddOn's transceivers are RoHS compliant and lead-free.

TAA refers to the Trade Agreements Act (19 U.S.C. & 2501-2581), which is intended to foster fair and open international trade. TAA requires that the U.S. Government may acquire only "U.S.-made or designated country end products."



Absolute Maximum Ratings

Parameter	Symbol	Min.	Typ.	Max.	Unit	Notes
Operating Case Temperature	Tc	0		70	°C	
Storage Temperature	Tstg	-40		85	°C	
Relative Humidity	RH			85	%	
Supply Voltage	Vcc	-0.5		3.6	V	
Data Rate	1G		1.25			
	10G		10.3125			

Electrical Characteristics

Parameter	Symbol	Min.	Typ.	Max.	Unit	Notes
Power Supply Voltage	Vcc	3.15	3.3	3.45	V	
Power Supply Current	Icc			300	mA	
Transmitter						
CML Differential Inputs	VIN	150		1200	mVp-p	1
Input AC Common-Mode Voltage		0		25	mV	RMS
Input Differential Impedance	ZIN	85	100	115	Ω	
Tx_Disable	High	2		Vcc	V	
	Low	0		0.8	V	
Tx_Fault	High	2		Vcc+0.3	V	2
	Low	0		0.5	V	3
Receiver						
CML Differential Outputs	VOUT	350		700	mVp-p	4
Output Differential Impedance	ZOUT	85	100	115	Ω	
Rx_LOS	High	2		Vcc+0.3		2
	Low	0		0.8		3
MOD_DEF(0.2)	VOH	2.5			V	5
	VOL	0		0.5	V	

Notes:

1. AC coupled inputs.
2. I_o=400μA; Host_Vcc.
3. I_o=-4.0mA.
4. AC coupled outputs.
5. With serial ID.

Optical Characteristics - 1G

Parameter	Symbol	Min.	Typ.	Max.	Unit	Notes
Transmitter						
Center Wavelength	λ_C	1540	1550	1560	nm	
Spectral Width (-20dB)	$\Delta\lambda$			1	nm	
Average Output Power	POUT	-9		-3	dBm	
Extinction Ratio	ER	9			dB	
Average Power of Off Transmitter	Poff			-30	dBm	
Side-Mode Suppression Ratio	SMSR	30			dB	
Transmitter Dispersion Penalty	TDP			3	dB	
Tx_Disable Assert Time	T_off			10	us	
Receiver						
Center Wavelength	λ_C	1300	1310	1320	nm	
Receiver Sensitivity	PMIN			-23	dBm	
Receiver Overload	PMAX	-3			dBm	
LOS De-Assert	LOSD			-23	dBm	
LOS Assert	LOSA	-38			dBm	
LOS Hysteresis	LOSH	0.5		6	dB	

Optical Characteristics - 10G

Parameter	Symbol	Min.	Typ.	Max.	Unit	Notes
Transmitter						
Center Wavelength	λ_C	1320	1330	1340	nm	
Spectral Width (-20dB)	$\Delta\lambda$			1	nm	
Average Output Power	POUT	-6		-0.5	dBm	
Extinction Ratio	ER	3.5			dB	
Average Power of Off Transmitter	Poff			-30	dBm	
Side-Mode Suppression Ratio	SMSR	30			dB	
Transmitter Dispersion Penalty	TDP			2	dB	
Tx_Disable Assert Time	T_off			10	us	
Receiver						
Center Wavelength	λ_C	1260	1270	1280	nm	
Receiver Sensitivity	PMIN			-15	dBm	
Receiver Overload	PMAX	0.5			dBm	
LOS De-Assert	LOSD			-16	dBm	
LOS Assert	LOSA	-28			dBm	
LOS Hysteresis	LOSH	0.5		6	dB	

Pin Descriptions

Pin	Symbol	Name/Description	Plug Seq.	Notes
1	VeeT	Transmitter Ground.	1	5
2	Tx_Fault	Transmitter Fault Indication.	3	1
3	Tx_Disable	Transmitter Disable. Module disables on “high” or “open.”	3	2
4	SDA	2-Wire Serial Interface Data.	3	3
5	SCL	2-Wire Serial Interface Clock.	3	3
6	MOD_ABS	Module Absent.	3	3
7	RS0	Rx Rate Select (LVTTTL).	3	
8	LOS	Loss of Signal.	3	4
9	RS1	Tx Rate Select (LVTTTL). Rate Select 1. Mode Select.	1	
10	VeeR	Receiver Ground.	1	5
11	VeeR	Receiver Ground.	1	5
12	RD-	Inverse Received Data Out.	3	6
13	RD+	Received Data Out.	3	6
14	VeeR	Receiver Ground.	1	5
15	VccR	+3.3V ± 5% Receiver Power.	2	7
16	VccT	+3.3V ± 5% Transmitter Power.	2	7
17	VeeT	Transmitter Ground.	1	5
18	TD+	Transmit Data In.	3	8
19	TD-	Inverse Transmit Data In.	3	8
20	VeeT	Transmitter Ground.	1	5

Notes:

1. Tx_Fault is an open collector/drain output that should be pulled up with a 4.7kΩ to 10kΩ resistor on the host board. Pull-up voltage between 2.0V and VccT/R+0.3V. When “high,” output indicates a laser fault of some kind. “Low” indicates normal operation. In the “low” state, the output will be pulled to <0.8V.
2. Tx_Disable is an input that is used to shut down the transmitter optical output. It is pulled up within the module with a 4.7kΩ to 10kΩ resistor. Its states are:
 - Low (0V to 0.8V): Transmitter On
 - (>0.8V and <2V): Undefined
 - High (2.0V to 3.465V): Transmitter Disabled
 - Open: Transmitter Disabled.
3. Modulation absent. Connected to the VeeT and VeeR in the module.
4. LOS (Loss of Signal) is an open collector/drain output that should be pulled up with a 4.7kΩ to 10kΩ resistor. Pull-up voltage between 2.0V and VccT/R+0.3V. When “high,” this output indicates that the received optical power is below the worst-case receiver sensitivity (as defined by the standard in use). “Low” indicates normal operation. In the “low” state, the output will be pulled to <0.8V.
5. VeeR and VeeT may be internally connected within the SFP module.
6. RD-/+. These are the differential receiver outputs. They are AC-coupled, 100Ω differential lines that

should be terminated with 100Ω (differential) at the user SERDES.

7. VccR and VccT are the receiver and transmitter power supplies.
8. TD-/+. These are the differential transmitter inputs. They are AC-coupled, differential lines with 100Ω differential termination inside the module.

Pin-Out Details

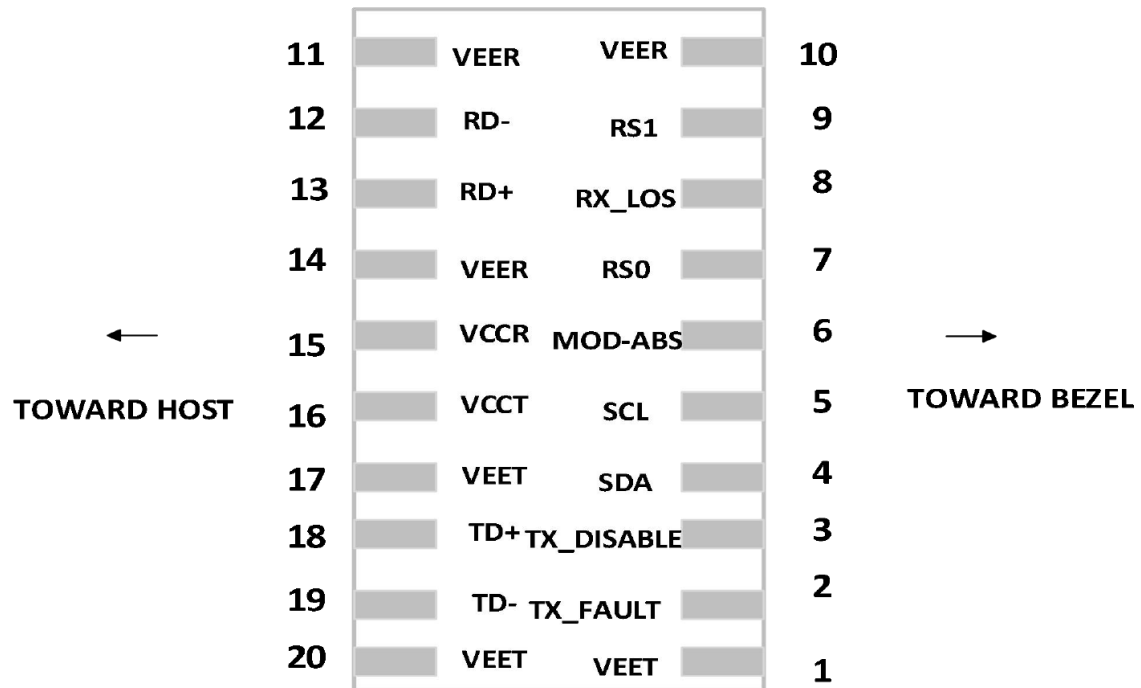

Mechanical Specifications

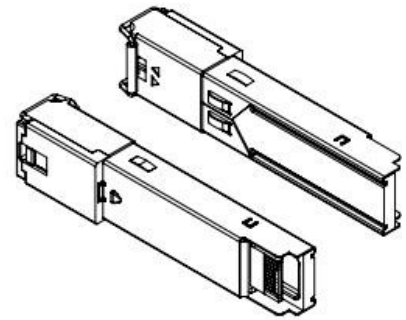
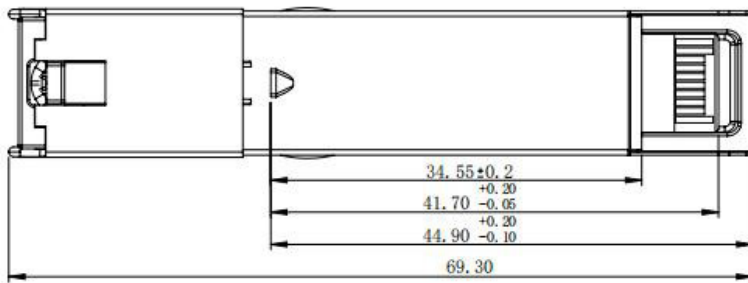
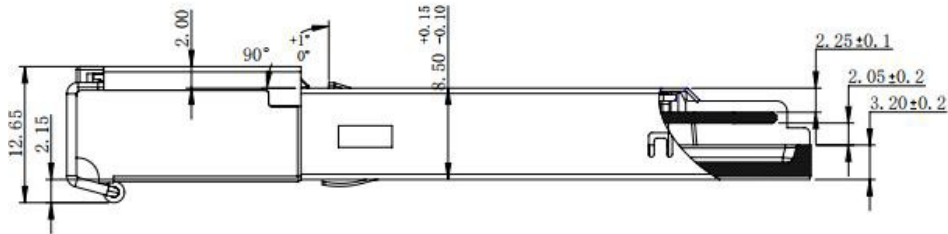
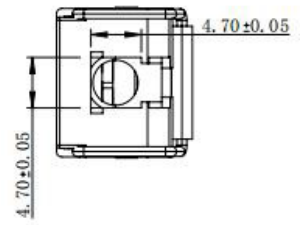
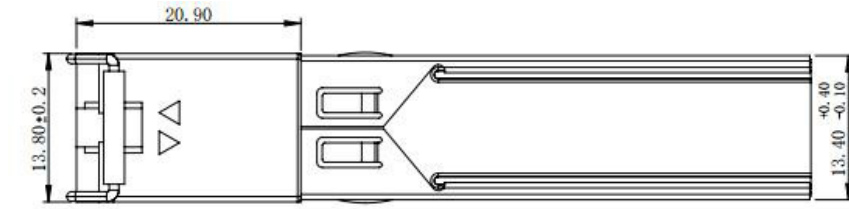

About AddOn Networks

In 1999, AddOn Networks entered the market with a single product. Our founders fulfilled a severe shortage for compatible, cost-effective optical transceivers that compete at the same performance levels as leading OEM manufacturers. Adhering to the idea of redefining service and product quality not previously had in the fiber optic networking industry, AddOn invested resources in solution design, production, fulfillment, and global support.

Combining one of the most extensive and stringent testing processes in the industry, an exceptional free tech support center, and a consistent roll-out of innovative technologies, AddOn has continually set industry standards of quality and reliability throughout its history.

Reliability is the cornerstone of any optical fiber network and is ingrained in AddOn's DNA. It has played a key role in nurturing the long-term relationships developed over the years with customers. AddOn remains committed to exceeding industry standards with certifications ranging from NEBS Level 3 to ISO 9001:2015 with every new development while maintaining the signature reliability of its products.



U.S. Headquarters

Email: sales@addonnetworks.com

Telephone: +1 877.292.1701

Fax: 949.266.9273

Europe Headquarters

Email: salesemea@addonnetworks.com

Telephone: +44 1285 842070