

Q28CT-OTU4-DCO-0DBM-AO

MSA (with select systems) TAA 100GbE/OTU4Base-ZR QSFP28 Transceiver (SMF, 1528.77nm to 1567.13nm, 80km, LC, DOM, 0 to 70C, CMIS) w/TOF, 0dbm

Features

- Hot-Pluggable QSFP28 Form Factor
- High Tx Output Power: 0dBm
- IEEE 100G Ethernet (CAUI-4) or ITU-T 100G OTN (OTL4.4) Compliant Host Interface
- Full C-Band Tunable, 50GHz/100GHz Spacing
- Power Dissipation: 6W
- Transmission Reach up to 80km Unamplified (Loss Limited) or up to 120km Amplified (Dispersion Limited, Optionally Extendable to 300km)
- RoHS Compliant and Lead-Free
- Operating Temperature: 0 to 70 Celsius
- Please contact your sales representative for specific system information



Applications

- Duplex Mux
- 100GBase Ethernet

Product Description

This MSA compliant (with select systems) high Tx power 0dBm with CMS and TOF, QSFP28 transceiver provides 100GbE/OTU4Base-ZR throughput up to 80km over single-mode fiber (SMF) using a wavelength of 1528.77nm to 1567.13nm via an LC connector. It can operate at temperatures between 0 and 70C. It has been programmed, uniquely serialized, and tested for data-traffic and application to ensure that it will initialize and perform identically. All of our transceivers comply with Multi-Source Agreement (MSA) standards to provide seamless network integration. Additional product features include Digital Optical Monitoring (DOM) support which allows access to real-time operating parameters. This transceiver is Trade Agreements Act (TAA) compliant. We stand behind the quality of our products and proudly offer a limited lifetime warranty.

AddOn's transceivers are RoHS compliant and lead-free.

TAA refers to the Trade Agreements Act (19 U.S.C. & 2501-2581), which is intended to foster fair and open international trade. TAA requires that the U.S. Government may acquire only "U.S.-made or designated country end products."



Absolute Maximum Ratings

Parameter	Symbol	Min.	Typ.	Max.	Unit	Notes
DC Supply Voltage	Vcc	-0.3		3.6	V	
Low-Speed I/O Voltages		-0.3		3.6	V	
Storage Temperature	Tstg	-40		85	°C	
Operating Case Temperature	Long-Term	Tc	0	70	°C	
	Short-Term < 96 Hours		-5	75	°C	
Operating Relative Humidity	RH	5		85	%	
Rx Input Power	PRx,in			10	dBm	
ESD Damage Threshold Human Body Model (HBM)	DC Pins		2000		V	
	RF Pins		1000		V	

Notes:

1. Stresses in excess of the Absolute Maximum Ratings can cause permanent damage to the device. These are absolute stress ratings only. Functional operation of the device is not implied at these or any other conditions in excess of those given in the operational sections of the datasheet. Exposure to Absolute Maximum Ratings for extended periods of time can adversely affect device reliability. Use of controls, adjustments, or performance of procedures other than those specified herein may result in hazardous radiation exposure.

Host Interface Modes

Host Interface ID [18]	Host Interface Description [18]	Modulation	Forward Error Correction Code	Nominal Symbol Rate (GBd)	Supported Line Interface IDs [18]
65 [9]	CAUI-4 C2M Without FEC	NRZ	None	25.78125	68, 192, 193
66 [9]	CAUI-4 C2M With RS(528,514) FEC	NRZ	RS(528,514)	25.78125	68, 192, 193
57 [10]	OTL4.4 (ITU-T G.709/Y1331 G.Sup58)	NRZ	RS(255, 239)	27.9525	192, 193

Electrical Characteristics

Parameter	Symbol	Min.	Typ.	Max.	Unit	Notes
Power Supply – General						
Power Supply Voltages		3.135	3.3	3.465	V	Including ripple, droop, and noise below 100kHz
Host RMS Noise Output				25	mV	10Hz - 10MHz
Module RMS Noise Output				15	mV	10Hz - 10MHz
Module Supply Noise Tolerance	PSNRmod			66	mV	10Hz - 10MHz, pk-pk
Module In-Rush	Tip			50	µs	Instantaneous peak duration
	Tinit			500	ms	Initialization time
Power Supply – Low-Power Mode						

Power Dissipation	Plp			1.5	W	
Power Supply Current	Icc,ip,lp			600	mA	Instantaneous peak current
	Icc,sp,lp			495	mA	Sustained peak current
	Icc,lp			478	mA	1, steady state current
Power Supply – High-Power Mode – 2.4ns/nm CD						
Power Dissipation	Php		5.5	6.2	W	
Power Supply Current	Icc,ip,hp			2480	mA	Instantaneous peak current
	Icc,sp,hp			2046	mA	Sustained peak current
	Icc,hp			1978	mA	1, steady state current
Power Supply – High-Power Mode – 6.0ns/nm CD						
Power Dissipation	Php		5.7	6.5	W	
Power Supply Current	Icc,ip,hp			2600	mA	Instantaneous peak current
	Icc,sp,hp			2145	mA	Sustained peak current
	Icc,hp			2073	mA	1, steady state current
Low-Speed I/O						
Clock Frequency (SCL)	fSCL		400		kHz	Default
			1000			Fast-mode+
Output Voltage (SCL and SDA)	VOL	0.0		0.4		Output low
	VOH	Vcc-0.5		Vcc+0.3		Output high
Input Voltage (SCL and SDA)	VIL	-0.3		0.63	V	Input low
	VIH	0.7×Vcc		Vcc+0.5		Input high
Capacitance for SCL and SDA I/O Signal	Ci			14	pF	
Total Bus Capacitive Load for SCL and SDA	400kHz Clock Rate	Cb		100	pF	2, 3.0kΩ pull-up resistor, maximum
				200		2, 1.6kΩ pull-up resistor, maximum
Input Voltage/Current, LPMode/TxDis, ResetL, and ModSelL	VIL	-0.3		0.8	V	Input voltage, low
	VIH	2.0		Vcc+0.3		Input voltage, high
	Iin	-365		125	μA	Input current, 0V < VIN < Vcc
Output Voltage, ModPrsL, and IntL/RxLOSL	VOL	0.0		0.4	V	Output low, IOL = 2mA
	VOH	Vcc-0.5		Vcc+0.3		Output high, 10kΩ pull-up resistor to Host_Vcc

Notes:

1. The module will stay within its advertised power class for all supply voltages.
2. For 1000kHz clock rate.

Optical Characteristics

Parameter	Symbol	Min.	Typ.	Max.	Unit	Notes
Power Supply – General						
Symbol Rate	Rbaud		27.95		GBd	
Modulation Format		DP-DQPSK				
Channel Frequency Range	Vc	191.4	193.7	196.1	THz	100GHz grid
	Vc	191.35	193.7	196.1	THz	50GHz grid
Channel Spacing	ΔVc		100		GHz	100GHz grid
	ΔVc		50		GHz	50GHz grid
Frequency Accuracy	δVc	-1.8		1.8	GHz	
Laser Intrinsic Linewidth	LW			500	kHz	Calculated based on FM noise Power Spectral Density (PSD) measurement
Side-Mode Suppression Ratio	SMSR	40			dB	No modulation
Relative Intensity Noise	RIN			-140	dB/Hz	Peak over 0.2GHz<f<10GHz
Transmitter						
Tx Output Power	PTx,out	0		3	dBm	
Tx Output Power Monitor Range	PTx,mon	-2		4	dBm	
Tx Output Power Monitor Accuracy	$\delta PTx,mon$	-1.5		1.5	dB	Tx optical power monitor reading relative to actual Tx output power
Tx Output Power During Tuning or When Tx is Disabled	PTx,dark			-35	dBm	
Tx Spectral Excursion		-15		15	GHz	ITU-T G.698.2 §7.2.3 [11]
Tx Output Power Imbalance Between X and Y Polarizations	$\Delta PX/Y$			1.5	dB	
Tx XY Skew				6.0	ps	
Tx IQ Offset				-25	dB	
Tx IQ Imbalance				1.0	dB	
Tx Quadrature Error		-7.0		7.0	°	
Tx IQ Skew				1.5	ps	
Tx Error Vector Magnitude Mask Ratio				23	%	ITU-T G.698.2 §7.2.12 [11], with 24dB/12.5GHz noise loading
Tx In-Band Optical Signal to Noise Ratio	OSNRin	39			dB/12.5GHz	Under modulation, $ \Delta f < 60\text{GHz}$
Tx Out-of-Band Optical Signal to Noise Ratio	OSNRout	45			dB/12.5GHz	Under modulation, $ \Delta f > 150\text{GHz}$
Tx Reflectance				-20	dB	
Receiver						
Rx Total Input Power	PRx,tot	-30		3	dBm	Broadband
Rx Signal Input Power (Amplified)	PRx,sig	-18		1	dBm	Full Rx OSNR tolerance
		-22		3	dBm	1

Rx OSNR Tolerance	100G DQPSK SC		16.5			dB/12.5GHz	2
	100G DQPSK RC		21.5				
CD Tolerance					2.4	ns/nm	Default, OSNR penalty <0.5dB
					6.0		3
PMD Tolerance					10	ps	4
DGD Tolerance					30	ps	4
Tolerance to Change in SOP					50	krad/s	4
PDL OSNR Penalty	1dB PDL				0.5	dB/12.5GHz	Change in principal state of polarization <1rad/ms
	2dB PDL				1.0		
	4dB PDL				3.0		
Rx Signal Input Power Transient Amplitude			-3		3	dB	5
Rx Signal Input Power Transient Rise/Fall Time			100			μs	6
Colorless Drop OSNR Penalty					0.5	dB	7
Colorless Drop Adjacent Channel Crosstalk Penalty					0.2	dB	8
Rx Signal Input Power (Unamplified)	100G DQPSK SC		-30		1	dBm	OSNR>35dB/12.5GHz
	100G DQPSK RC		-24		1		
Rx Signal Input Power Monitor Range		PR _{x,mon(s)}	-21		3	dBm	
Rx Signal Input Power Monitor Accuracy		δPR _{x,mon(s)}	-2.5		2.5	dB	
Rx Total Input Power Monitor Range		PR _{x,mon(t)}	-21		6	dBm	
Rx Total Input Power Monitor Accuracy		δPR _{x,mon(t)}	-2.0		2.0	dB	
Rx Reflectance					-20	dB	

Notes:

1. Extended range. Rx signal input power range over which performance can be guaranteed with <1dB OSNR penalty relative to the Rx OSNR tolerance limit.
2. Back-to-back, PR_{x,sig}>-18dBm. Rx OSNR tolerance for Carrier Frequency Offset |CFO|<1GHz. Up to 1dB penalty for worst case |CFO|=3.6GHz.
3. Extended, OSNR penalty <1.0dB. Power dissipation will increase by approximately 0.2W if extended CD compensation is enabled.
4. OSNR penalty <0.5dB.
5. Peak excursion from steady state, transient within Rx signal input power (amplified) range and OSNR penalty is <0.5dB.
6. Rise/fall time for the above peak excursion, OSNR penalty is <0.5dB.
7. Rx total input power to signal input power ratio <12dB. Receiver is able to tolerate the specified ratio of total power of crosstalk channels and ASE to signal power with the specified OSNR penalty. Does not include contribution from adjacent channel crosstalk. No single channel power exceeding signal channel power by more than 1dB shall be included. Measured at Rx signal input power -6dBm.
8. Measured at the Rx OSNR limit, 50GHz channel spacing, and both adjacent channels <1dB higher power than signal channel.

Common Management Interface Specifications (CMIS)

Parameter	Symbol	Min.	Max.	Unit	Conditions	Notes
MgmtInitDuration			2000	ms	Time from power on, hot plug, or rising edge of reset until the high-to-low SDA transition of the start condition for the first acknowledged TWI transaction.	1
ResetL Assert Time		10		µs	Minimum pulse time on the ResetL signal to initiate a module reset.	
IntL/RxLOS Mode Change Time			100	ms	Time to change between IntL and RxLOS modes of the dual-mode signal IntL/RxLOS.	
LPMoDe/TxDis Mode Change Time			100	ms	Time to change between LPMoDe and TxDis modes of the LPMoDe/TxDis signal.	
IntL Assert Time			200	ms	Time from occurrence of condition triggering IntL until VOUT:intL=VOL.	
IntL De-Assert Time			500	µs	Time from clear on read operation of associated flag until VOUT:IntL=VOH. This includes de-assert times for RxLOS, Tx Fault, and other flag bits.	2
RxLOS Assert Time			1	ms	Time from RxLOS condition present to RxLOS bit set (value = 1b) and IntL asserted.	3
RxLOS De-Assert Time			15	ms	Time from optical signal above the LOS de-assert threshold to when the module releases the RxLOS signal to high.	
Tx Disable Assert Time			1	ms	Time from Tx Disable bit set (value = 1b) until optical output falls below 10% of nominal.	4
Tx Disable De-Assert Time			10	s	Time from Tx Disable bit cleared (value = 0b) until optical output rises above 90% of nominal.	4
Tx Fault Assert Time			200	ms	Time from Tx Fault state to Tx Fault bit set (value = 1b) and IntL asserted.	
Flag Assert Time			200	ms	Time from occurrence and condition triggering flag to associated flag bit set (value = 1b) and IntL asserted.	
Mask Assert Time			100	ms	Time from mask bit set (value = 1b) until the associated IntL assertion is inhibited.	5
Mask De-Assert Time			100	ms	Time from mask bit cleared (value = 0b) until associated IntL operation resumes.	5
Data Path Tx Turn On Max. Duration	See CMIS memory P01h: B168				Maximum duration of Tx Turn On state.	6
Data Path Tx Turn Off Max. Duration	See CMIS memory P01h: B168				Maximum duration of Tx Turn Off state.	6
Data Path De-Init. Max. Duration	See CMIS memory P01h: B144				Maximum duration of DataPathDeInit state.	6
Data Path Init. Max. Duration	See CMIS memory P01h: B144				Maximum duration of DataPathInit state.	6
Module Pwr Up Max. Duration	See CMIS memory P01h: B167				Maximum duration of Module Pwr Up state.	7
Module Pwr Dn Max. Duration	See CMIS memory P01h: B167				Maximum duration of Module Pwr Dn state.	7
I/O Timing for Squelch & Disable						
Rx Squelch Assert Time			15	ms	Time from loss of Rx input signal until the squelched output condition is reached.	
Rx Squelch De-Assert Time			15	ms	Time from resumption of Rx input signals until normal Rx output condition is reached.	
Tx Squelch Assert Time			400	ms	Time from loss of Tx input signal until the squelched output condition is reached.	
Tx Squelch De-Assert Time			10	s	Time from resumption of Tx input signal until the normal Tx output condition is reached.	
Rx Output Disable Assert Time			100	ms	Time from Rx Output Disable bit set (value = 1b) until Rx output falls below 10% of nominal.	4

Rx Output Disable De-Assert Time			100	ms	Time from Rx Output Disable bit cleared to (value = 0B) until Rx output rises above 90% of nominal.	4
Squelch Disable Assert Time			100	ms	This applies to Rx and Tx Squelch and is the time from bit set (value = 1b) until squelch functionality is disabled.	4
Squelch Disable De-Assert Time			100	ms	This applies to Rx and Tx Squelch and is the time from bit cleared (value = 0b) until squelch functionality is enabled.	4

Notes:

1. "Power On" is defined as the instant when supply voltages reach and remain at or above the minimum level specified.
2. Measured from the rising edge of SDA during STOP sequence of write transaction.
3. RxLOS condition is defined as a Rx input power below threshold or DSP loss of signal.
4. Measured from low-to-high SDA signal transition of the STOP condition of the write transaction.
5. Measured from low-to-high SDA edge of the STOP condition of the write transaction.
6. Measured from the low-to-high SDA edge of the STOP condition of the write transaction until the IntL for the state change VOUT:IntL=VOL, unless the module advertises a less than 1ms duration in which case there is no defined measurement.
7. Measured from the low-to-high SDA edge of the STOP condition of the write transaction until the IntL for the state change VOUT:IntL=VOL.

Optical Timing Characteristics

Parameter	Symbol	Min.	Max.	Unit	Conditions	Notes
Tx Turn On Time			10	s	Warm Start	1
			120	s	Cold Start	
Rx Acquisition Time			30	ms	Warm Start	
			120	s	Cold Start	
Tx/Rx Channel Tuning Time		10	30	s		

Notes:

1. Assumes the Tx/Rx laser is already tuned to the correct frequency.

Pin Descriptions

Pin	Logic	Symbol	Name/Description	Plug Sequence	Notes
1		GND	Module Ground.	1	1
2	CML-I	Tx2-	Transmitter Inverted Data Input.	3	
3	CML-I	Tx2+	Transmitter Non-Inverted Data Input.	3	
4		GND	Module Ground.	1	1
5	CML-I	Tx4-	Transmitter Inverted Data Input.	3	
6	CML-I	Tx4+	Transmitter Non-Inverted Data Input.	3	
7		GND	Module Ground.	1	1
8	LVTTTL-I	ModSelL	Module Select.	3	
9	LVTTTL-I	ResetL	Module Reset.	3	
10		VccRx	+3.3V Receiver Power Supply.	2	2
11	LVCNOS-I/O	SCL	2-Wire Serial Interface Clock.	3	
12	LVCNOS-I/O	SDA	2-Wire Serial Interface Data.	3	
13		GND	Module Ground.	1	1
14	CML-O	Rx3+	Receiver Non-Inverted Data Output.	3	
15	CML-O	Rx3-	Receiver Inverted Data Output.	3	
16		GND	Module Ground.	1	1
17	CML-O	Rx1+	Receiver Non-Inverted Data Output.	3	
18	CML-O	Rx1-	Receiver Inverted Data Output.	3	
19		GND	Module Ground.	1	1
20		GND	Module Ground.	1	1
21	CML-O	Rx2-	Receiver Inverted Data Output.	3	
22	CML-O	Rx2+	Receiver Non-Inverted Data Output.	3	
23		GND	Module Ground.	1	1
24	CML-O	Rx4-	Receiver Inverted Data Output.	3	
25	CML-O	Rx4+	Receiver Non-Inverted Data Output.	3	
26		GND	Module Ground.	1	1
27	LVTTTL-O	ModPrsL	Module Present.	3	
28	LVTTTL-O	IntL/RxLOSL	Interrupt. Optionally configurable as RxLOSL via the management interface (CMIS).	3	
29		VccTx	+3.3V Transmitter Power Supply.	2	2
30		Vcc1	+3.3V Power Supply.	2	2
31	LVTTTL-I	LPMODE/TxDis	Low-Power Mode. Optionally configurable as TxDis via the management interface (CMIS).	3	
32		GND	Module Ground.	1	1
33	CML-I	Tx3+	Transmitter Non-Inverted Data Input.	3	
34	CML-I	Tx3-	Transmitter Inverted Data Input.	3	
35		GND	Module Ground.	1	1
36	CML-I	Tx1+	Transmitter Non-Inverted Data Input.	3	
37	CML-I	Tx1-	Transmitter Inverted Data Input.	3	
38		GND	Module Ground.	1	1

Notes:

1. GND is the symbol for signal and supply (power) common for the module. All are common within the module, and all module voltages are referenced to this potential unless otherwise noted. Connect these directly to the host board signal common ground plane.
2. VccRx, Vcc1, and VccTx are applied concurrently and may be internally connected within the module in any combination.
3. Plug Sequence specifies the mating sequence of the host connector and module. The sequence is 1, 2, and 3. See figure below for pad locations.

Electrical Pad Layout



Block Diagram

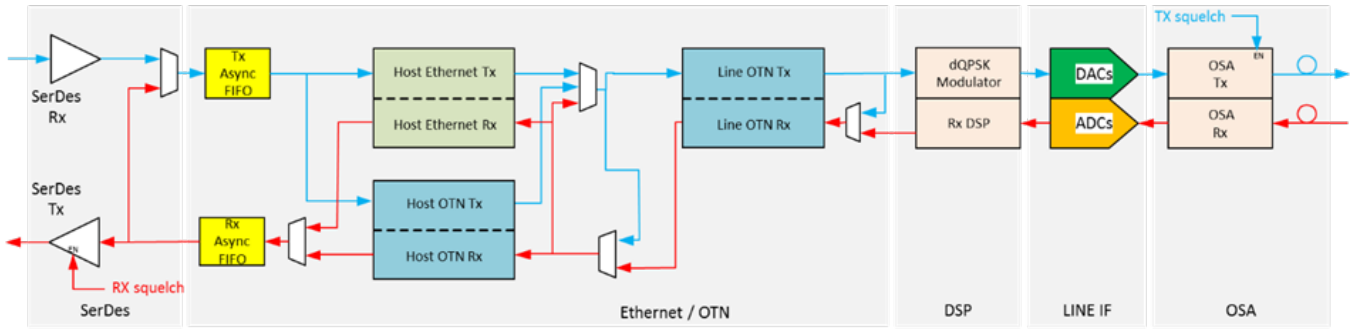

Mechanical Specifications

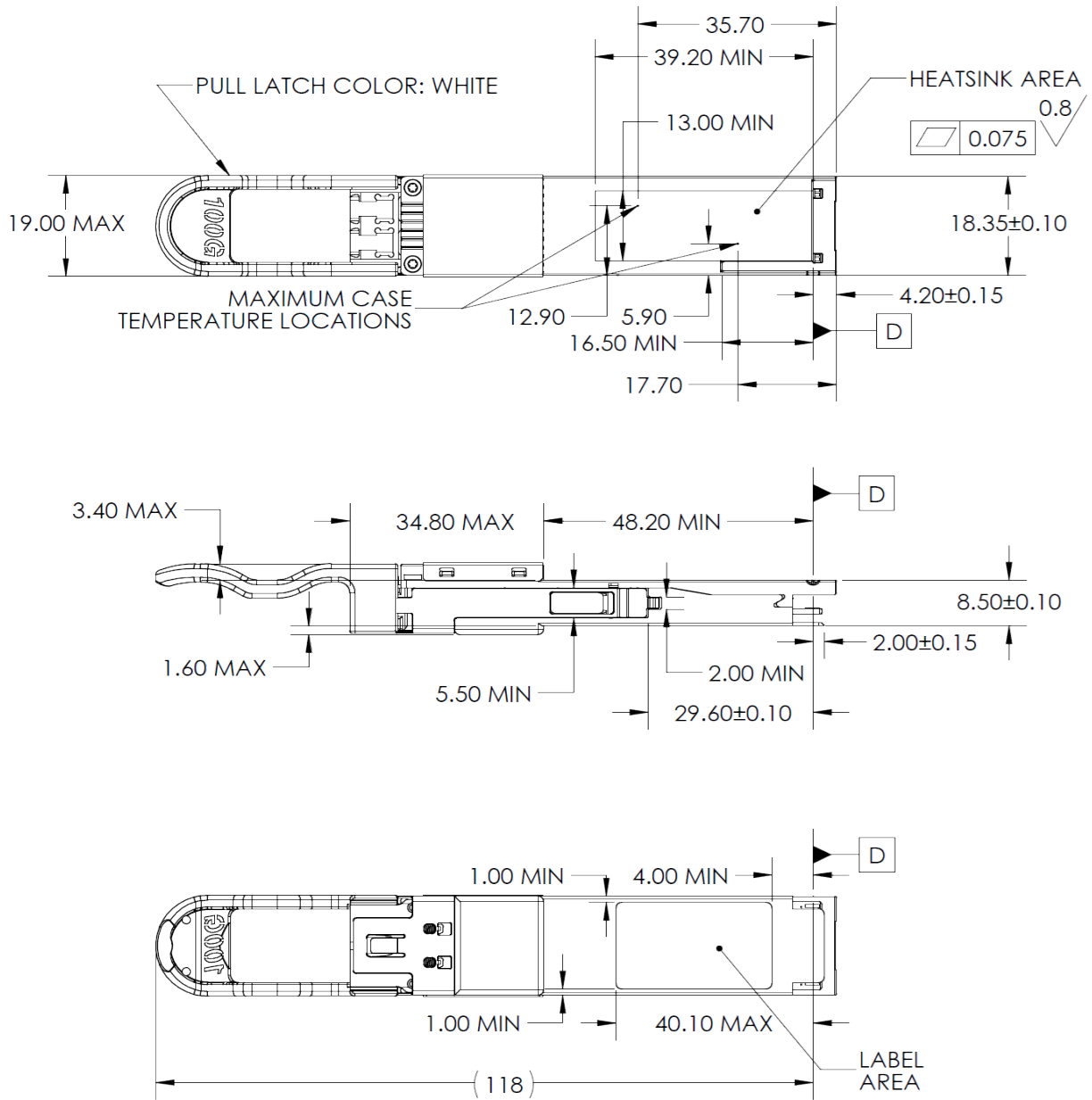

About AddOn Networks

In 1999, AddOn Networks entered the market with a single product. Our founders fulfilled a severe shortage for compatible, cost-effective optical transceivers that compete at the same performance levels as leading OEM manufacturers. Adhering to the idea of redefining service and product quality not previously had in the fiber optic networking industry, AddOn invested resources in solution design, production, fulfillment, and global support.

Combining one of the most extensive and stringent testing processes in the industry, an exceptional free tech support center, and a consistent roll-out of innovative technologies, AddOn has continually set industry standards of quality and reliability throughout its history.

Reliability is the cornerstone of any optical fiber network and is ingrained in AddOn's DNA. It has played a key role in nurturing the long-term relationships developed over the years with customers. AddOn remains committed to exceeding industry standards with certifications ranging from NEBS Level 3 to ISO 9001:2015 with every new development while maintaining the signature reliability of its products.



U.S. Headquarters

Email: sales@addonnetworks.com

Telephone: +1 877.292.1701

Fax: 949.266.9273

Europe Headquarters

Email: salesemea@addonnetworks.com

Telephone: +44 1285 842070