

SFPP-XGS-ONU-N1-I-AO

MSA and TAA Compliant 10GBase-N1 XFP OLT Transceiver (SMF, 1577nmTx/1270nmRx, 20km, SC, DOM)

Features

- 2x10 SFP+ Die Cast Housing
- SC Optical Receptacle
- One single-mode fiber
- Bidirectional Operation
- Dual Wavelength
- Low Power Consumption
- 9.95328Gb/s Burst Mode Tx Data Rate
- 9.95328Gb/s CW Mode Rx Data Rate
- Single 3.3V DC Input Voltage
- Operating Temperature: -40°C to 85°C
- RoHS compliant and Lead Free



Applications:

- Symmetric XGS-PON Access networks
- FTTH
- FTTB
- FTTC

Product Description:

This MSA compliant SFP+ ONU transceiver provides 10GBase-N1 throughput up to 20km over single-mode fiber (SMF) using a wavelength of 1270nmTx/1577nmRx and 1310nmTx/1490nmRx via a SC connector. It is also capable of withstanding rugged environments and can operate at temperatures between -40°C to 85°C. It is built to MSA standards and is uniquely serialized and data-traffic and application tested to ensure that they will integrate into your network seamlessly. Digital optical monitoring (DOM) support is also present to allow access to real-time operating parameters. This transceiver is Trade Agreements Act (TAA) compliant. We stand behind the quality of our products and proudly offer a limited lifetime warranty.

AddOn's transceivers are RoHS compliant and lead-free.

TAA refers to the Trade Agreements Act (19 U.S.C. & 2501-2581), which is intended to foster fair and open international trade. TAA requires that the U.S. Government may acquire only "U.S. – made or designated country end products."



Regulatory Compliance

- ESD to the Electrical PINs: compatible with MIL-STD-883E Method 3015.4
- ESD to the LC Receptacle: compatible with IEC 61000-4-3
- EMI/EMC compatible with FCC Part 15 Subpart B Rules, EN55022:2010
- Laser Eye Safety compatible with FDA 21CFR, EN60950-1& EN (IEC) 60825-1,2
- RoHS compliant with EU RoHS 2.0 directive 2015/863/EU

Absolute Maximum Ratings

Parameter	Symbol	Min.	Typ.	Max.	Unit
Maximum Supply Voltage	VCC3	0		3.6	V
Storage Ambient Temperature	T _{stg}	-40		+85	°C
Operating Case Temperature	T _c	-40	25	85	°C
Relative Humidity Storage	RH _{Stg}	0		95	%
Relative Humidity Operating	RH _{Op}	0		85	%

Note:

Exceeding the Absolute Maximum Ratings may cause irreversible damage to the device. The device is not intended to be operated under the condition of simultaneous Absolute Maximum Ratings, a condition which may cause irreversible damage to the device.

Absolute Maximum Ratings: Control Function Logic Levels

Parameter	Symbol	Min.	Max.	Unit	Notes
Receiver LOSS OF SIGNAL Logic State	RX_LOS	0	V _{CC} +0.5	V	LVTTTL
Transmit Burst_Enable Logic State	BM _{ENABLE}	0	V _{CC} +0.5	V	LVTTTL

Electrical Characteristics

Parameter	Symbol	Min.	Typ.	Max.	Unit	Notes
Power Supply Voltage	V _{CC}	3.135	3.30	3.465	V	
Power Supply Current	I _{IN}		480		mA	
Transmitter						
Tx_Data Differential Input Voltage	V _{IN}	190		700	mV	
Tx_DIS= HIGH (Transmitter OFF / DISABLED)	V _{IH}	2.0		V _{CC} +0.3	V	1
Tx_DIS = LOW (Transmitter ON / ENABLED)	V _{IL}	0		0.8	V	1
Receiver						
Rx_Data Differential Output Voltage	V _{OUT}	300		850	mV	2
Rx_LOS = HIGH (Receiver OFF)	V _{OH}	2.4		3.3	V	LVTTL
Rx_LOS = LOW (Receiver ON)	V _{OL}	0		0.8	V	LVTTL

Notes:

1. LVTTL Burst Mode
2. CML Rx_DATA Electrical Output (AC coupled internally)

Optical Characteristics

Parameter	Symbol	Min.	Typ.	Max.	Unit	Notes
Transmitter						
Laser Type		DFB Laser				
Transmitter Signal Rate		9.95328			Gb/s	
Average Output Power	P _{out}	+4		+9	dBm	
Optical Center Wavelength	λ	1260	1270	1280	nm	
Spectral Width	Δλ			1	nm	
Side Mode Suppression Mode	SMSR	30			dB	
Extinction Ratio	ER	6			dB	
Burst-On Time	T _{Burst_On}			50	ns	
Burst-Off Time	T _{Burst_Off}			50	ns	
Receiver						
Receiver Type		CW APD/TIA				
Receiver Signal Rate		9.95328			Gb/s	
Optical Center Wavelength	λ		1577		nm	
Receiver Sensitivity	P _{EOLO}			-28	dBm	1
Received Optical Overload	P _{IN(SAT)}	-8			dBm	1
Rx_LOS Assert	P _A	-42			dBm	
Rx_LOS De-assert	P _D			-29	dBm	
Rx_LOS Hysteresis	P _{Hy}	0.5		5	dB	

Notes:

1. BER ≤ 10⁻³ PRBS 2³¹-1 ER=8dB

Pin Descriptions

Pin	Symbol	Name/Descriptions	Ref.
1	GND	Module Ground.	
2	Tx_FAULT	Transmitter Fault.	1
3	BURST_ENABLE	Burst Enable Input; When asserted High, Transmitter output is turned OFF.	
4	SDA	2-wire Serial Interface Data Line (MOD-DEF2).	
5	SCL	2-wire Serial Interface Clock (MOD-DEF1).	
6	MOD_ABS	Module Absent, connected to V _{EET} .	1
7	Tx_SD	Transmitter State Indication, Tx_Indication Assert High, When Transmitter ON.	
8	Rx_LOS	Loss of Signal indication. Logic 0 indicates normal operation.	1
9	P_Down	Power Down High=Normal Operation, Low=Power Down (Only Power down TX)	2
10	GND	Module Ground.	
11	GND	Module Ground.	
12	RD-	Receiver Inverted DATA out. AC Coupled.	
13	RD+	Receiver Non-inverted DATA out. AC Coupled.	
14	GND	Module Ground.	
15	VCCR	Receiver Power Supply.	
16	VCCT	Transmitter Power Supply.	
17	GND	Module Ground.	
18	TD+	Transmitter Non-Inverted DATA in. AC Coupled.	
19	TD-	Transmitter Inverted DATA in. AC Coupled.	
20	GND	Module Ground.	

Notes:

1. Shall be pulled up with 4.7k-10kohms to a voltage between 3.15V and 3.6V on the host board.
2. 4.7k to 10k pull-up resistor within the module.

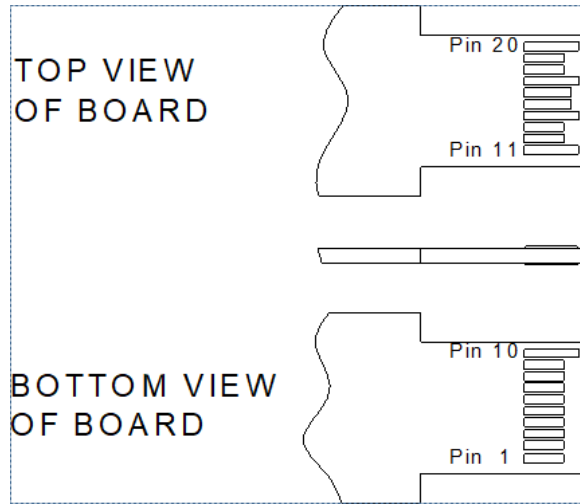

Electrical Interface

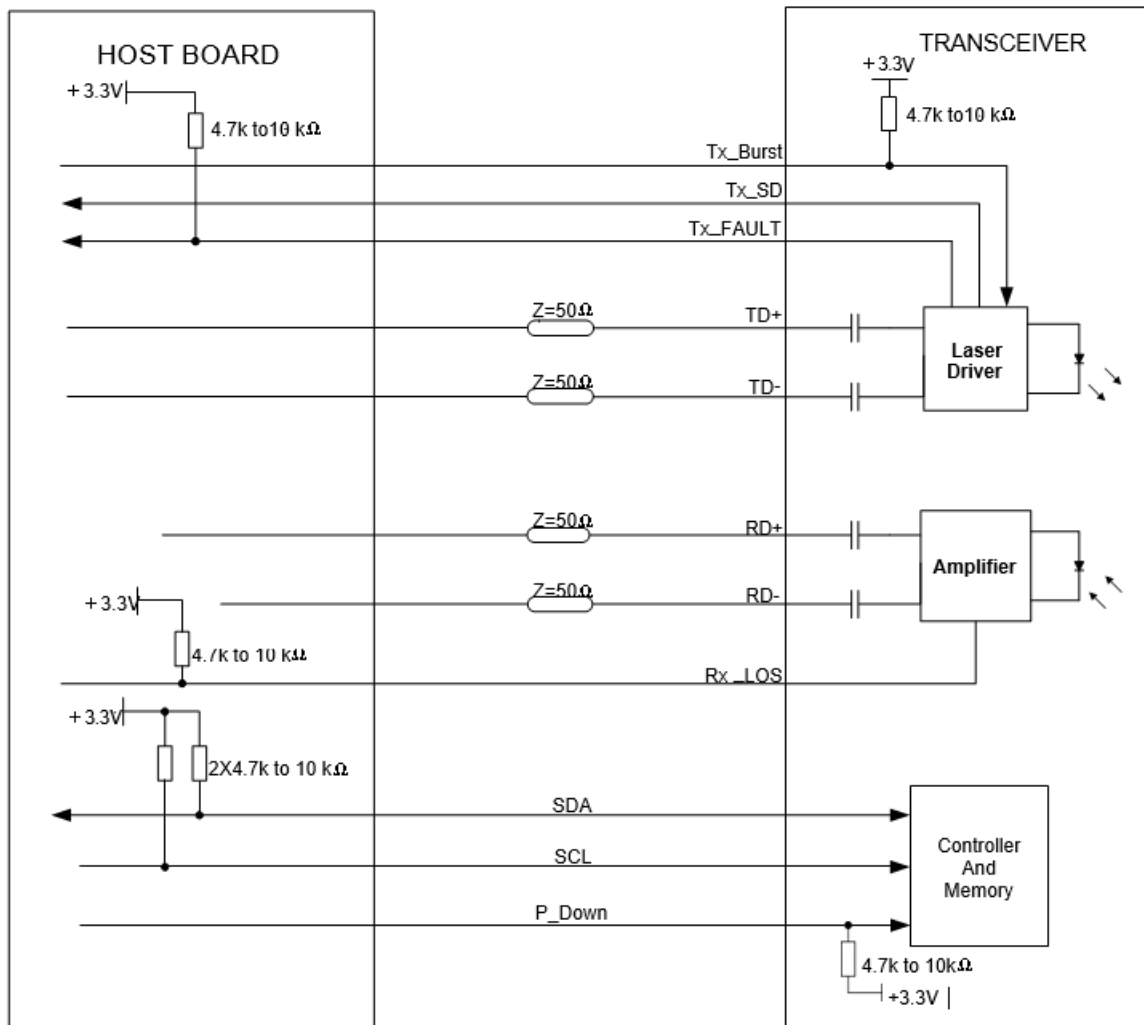

Mechanical Specifications

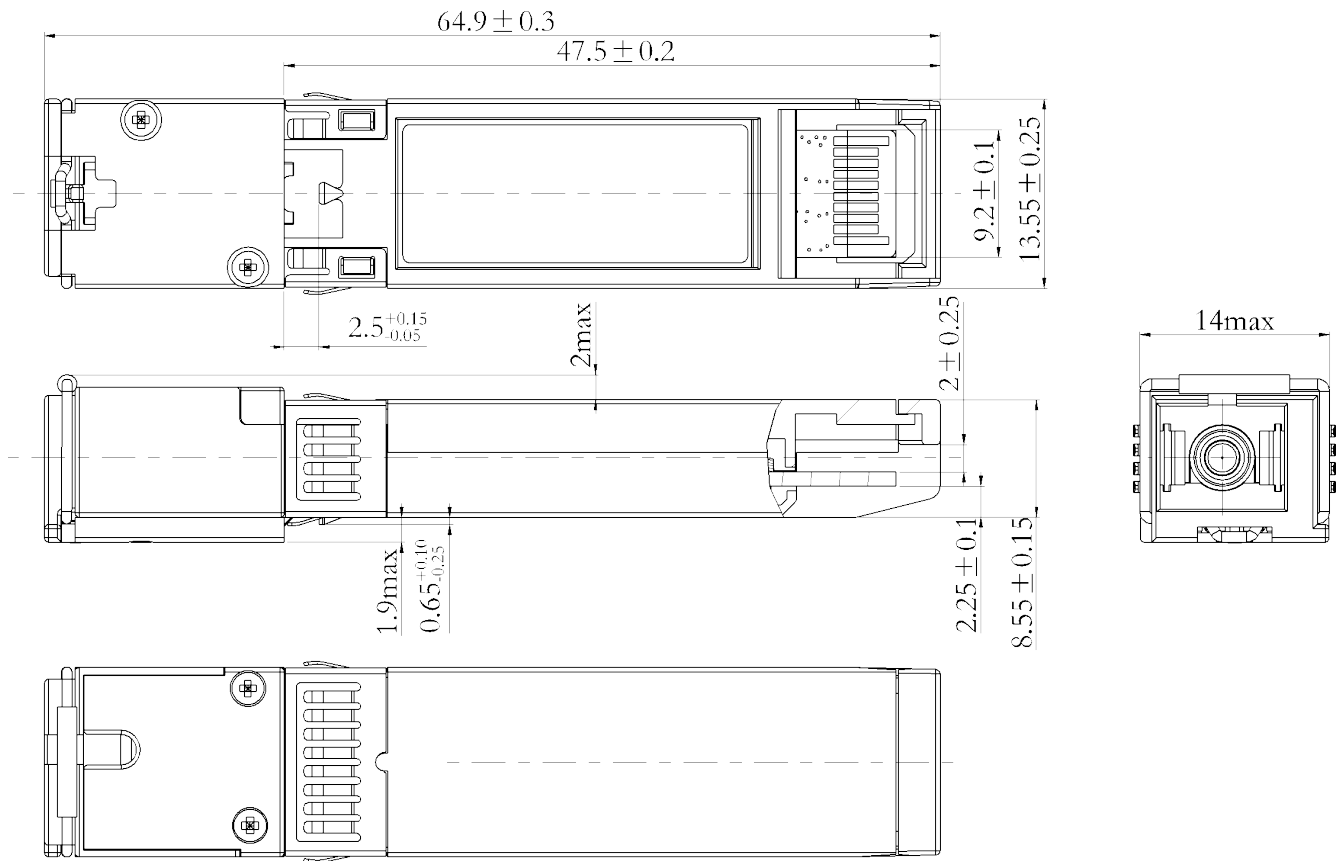

NOTES:

- 1.TOLERANCE: $\pm 0.1\text{MM}$.
- 2.OTHERS ACCORDING WITH SFF-8074/SFF-8432 OR CUSTOMER SPEC.
- 3.LIGHT PORT ACCORDING WITH FIBER CONNECTOR SPEC.

EEPROM Information

EEPROM memory map specific data field description is as below:

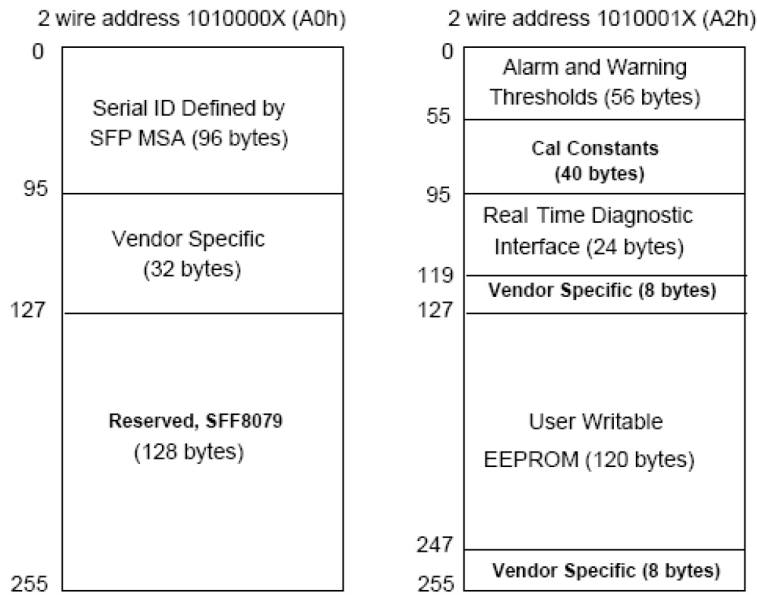

Contact Information

Founded in 1999, AddOn Networks is North America's leading provider of transceivers and high speed cabling. With a reputation for high quality products as well as an extensive custom design portfolio, AddOn has the connectivity solution regardless of the requirement.

At AddOn, 100% of the products we ship every day are tested in the specific application for which they are intended—never batch or spec tested only. We run bandwidth, distance and IOS network tests. We have documented an impressive 0.03% failure rate over the last 10 years. To continue this rate of success we invest millions annually in our own on-site testing lab.

Corporate office:
AddOn Networks
15775 Gateway Circle
Tustin, CA 92780

Tel: 877-292-1701
Fax: 949-266-9273
Email: sales@addonnetworks.com
Email: support@addonnetworks.com
Web: <http://www.addonnetworks.com>