

SFPP-XGS-OLT-N1B+-C

MSA and TAA 1G/10GBase-N1/B+ SFP+ OLT Transceiver (SMF, 1577nmTx/1270nmRx and 1490nmTx/1310nmRx, 20km, SC, DOM)

Features:

- Hot Pluggable SFP+
- 3.3V DC Power Supply
- 4 Lambda
- SC receptacle optical connector
- 2x10 SFP+ Electrical Interface
- ITU-T G.9807.1 Class N1/N2 compliant
- ITU-T G.987.2 Class N1/N2a compliant
- ITU-T G.984.2 Class B+/C+ compliant
- Operating Temperature: 0C to 70C
- RoHS compliant and Lead Free



Applications:

- PON
- Broadband Access

Product Description

This MSA Compliant SFP+ transceiver provides 10GBase-N1/B+ throughput up to 20km over single-mode fiber (SMF) using a wavelength of 1577nmTx/1270nmRx and 1490nmTx/1310nmRx via a SC connector. It is built to MSA standards and is uniquely serialized and data-traffic and application tested to ensure that they will integrate into your network seamlessly. Digital optical monitoring (DOM) support is also present to allow access to real-time operating parameters. This transceiver is Trade Agreements Act (TAA) compliant. We stand behind the quality of our products and proudly offer a limited lifetime warranty.

ProLabs' transceivers are RoHS compliant and lead-free.

TAA refers to the Trade Agreements Act (19 U.S.C. & 2501-2581), which is intended to foster fair and open international trade. TAA requires that the U.S. Government may acquire only "U.S. – made or designated country end products."



Absolute Maximum Ratings

Parameter	Symbol	Min.	Max.	Unit
Maximum Supply Voltage	VCC3	0	3.6	V
Storage Ambient Temperature	T _{stg}	-40	+85	°C
Operating Case Temperature	T _c	0	70	°C
Relative Humidity Storage	RH _s	5	90	%
Relative Humidity Operating	RH _o	5	85	%

Note:

Exceeding the Absolute Maximum Ratings may cause irreversible damage to the device. The device is not intended to be operated under the condition of simultaneous Absolute Maximum Ratings, a condition which may cause irreversible damage to the device.

Absolute Maximum Ratings: Control Function Logic Levels

Parameter	Symbol	Min.	Max.	Unit	Notes
Tx_DISABLE	Tx_Dis	0	V _{CC3} +0.5	V	LVTTTL
Burst Mode SIGNAL Detect	Rx_SD	0	V _{CC3} +0.5	V	LVTTTL
Rx_Reset	Rx_Reset	0	V _{CC3} +0.5	V	1
Digital Rx_RSSI_Trigger Input	TRI	0	V _{CC3} +0.5	V	1
I ² C Serial Data	SDA	0	V _{CC3} +0.5	V	2
I ² C Serial Clock	SCL	0	V _{CC3} +0.5	V	1

Notes:

1. Signal Ended LVTTTL input
2. Single Ended LVTTTL I/O

Electrical Characteristics

Parameter	Symbol	Min.	Typ.	Max.	Unit	Notes
Power Supply Voltage	V _{CC3}	3.135	3.30	3.465	V	
Power Supply Current	I _{CC3}		750		mA	
Power Consumption	P			3.5	W	
Transmitter						
Tx Differential Input Impedence	Z _{IN}	90	100	110	Ω	
10Gb/s Tx Differential Input Amplitude	V _{IN10}	120		800	mV	
2.5Gb/s Tx Differential Input Amplitude	V _{IN1}	120		800	mV	
Tx_Dis = HIGH (Transmitter OFF / DISABLED)	V _{TDH}	0.7*V _{CC3}		V _{CC3}	V	1
Tx_Dis = LOW (Transmitter ON / ENABLED)	V _{TDL}	0		0.8	V	1
Receiver						
Rx Differential Output Impedence	Z _{OUT}	90	100	110	Ω	
10Gb/s Rx_Data Differential Output Voltage Amplitude	V _{OUT10}	300		850	mV	LVCML
10Gb/s Output HIGH Voltage	V _{OH10}	V _{CC3} -20	V _{CC3} -5	V _{CC3}	mV	LVCML
10Gb/s Output LOW Voltage	V _{OL10}	V _{CC3} -400	V _{CC3} -350	V _{CC3} -300	mV	LVCML
1.25Gb/s Rx_Data Differential Output Voltage Amplitude	V _{OUT1}	600		1600	mV	LVPECL
1.25Gb/s Output HIGH Voltage	V _{OH1}	V _{CC3} -1085	V _{CC3} -955	V _{CC3} -880	mV	LVPECL
1.25Gb/s Output LOW Voltage	V _{OL1}	V _{CC3} -1850	V _{CC3} -1705	V _{CC3} -1555	mV	LVPECL
Rx_SD = HIGH (Receiver ON)	V _{OH}	2.0		V _{CC3}	V	2
Rx_SD = LOW (Receiver OFF)	V _{OL}	0		0.8	V	2
Ratesel/Reset=HIGH	V _{IH}	1.9		V _{CC3}	V	3
Ratesel/Reset=Middle	V _{IM}	1.2		1.6	V	3
Ratesel/Reset=LOW	V _{IL}	0		0.9	V	3
TRI=HIGH	V _{IH}	0.7*V _{CC3}		V _{CC3}	V	1
TRI=LOW	V _{IL}	0		0.8	V	1

Notes:

1. LVTTTL (Control INPUT)
2. LVTTTL (Monitor OUTPUT)
3. Tri-level (Control INPUT)

9.95328Gb/s Transmitter Optical Characteristics

Parameter	Symbol	Min.	Typ.	Max.	Unit	Notes
Laser Type		1577nm CW EML				
Downstream Signal Rate		9.95328			Gb/s	
Average Launch Power	P_{OUT10}	2		5	dBm	
Optical Center Wavelength	λ_{10}	1575		1580	nm	
Spectral Width	$\Delta\lambda_{10}$			1.0	nm	
Side Mode Suppression Ratio	$SMSR_{10}$	30			dB	
Extinction Ratio	ER_{10}	8.2			dB	
Output Eye Diagram	Compliant with ITU-T G.987.2 & ITU-T G.9807.1					

2.48832Gb/s Transmitter Optical Characteristics

Parameter	Symbol	Min.	Typ.	Max.	Unit	Notes
Laser Type		1490nm CW DFB Laser				
Downstream Signal Rate		2.48832			Gb/s	
Average Launch Power	P_{OUT2}	1.5	2.5	5	dBm	
Optical Rise and Fall Time	T_r / T_f			200	ps	20% to 80%
Optical Center Wavelength	λ_1	1480	1490	1500	nm	
Spectral Width	$\Delta\lambda_1$			1.0	nm	
Side Mode Suppression Ratio	$SMSR_1$	30			dB	
Extinction Ratio	ER_1	8.2			dB	
Output Eye Diagram	Compliant with ITU-T G.984.2					

9.95328/2.48832Gb/s Receiver Optical Characteristics

Parameter	Symbol	Min.	Typ.	Max.	Unit	Notes
Receiver Type		1270nm APD/TIA Receiver				
Upstream Signal Rate		9.95328/2.48832			Gb/s	
Optical Center Wavelength	λ	1260	1270	1280	nm	
XGS-PON Receiver Sensitivity	P_{IN}			-26	dBm	1
XG-PON Receiver Sensitivity	P_{IN}			-27.5	dBm	2
XGS-PON Receiver Optical Overload*	$P_{IN}(SAT)$	-5			dBm	3
XG-PON Receiver Optical Overload*	$P_{IN}(SAT)$	-7			dBm	3
Damaged Input Optical Power	P_d			-5	dBm	
Rx_SD Assert	P_A	-45		-29.5	dBm	
Rx_SD De Assert	P_D	-45		-29.5	dBm	
Rx_SD Hysteresis	PHy	0		7	dBm	

Notes:

1. BER@ 10^{-3} *: Test Condition: PRBS: $2^{31}-1$, ER=8.2 dB
2. BER@ 10^{-4} *: Test Condition: PRBS: $2^{23}-1$, ER=8.2 dB
3. Test Condition: BER@ 10^{-10} , PRBS $2^{23}-1$, ER=10dB

1.24416Gb/s Receiver Optical Characteristics

Parameter	Symbol	Min.	Typ.	Max.	Unit	Notes
Receiver Type		1310nm Burst APD/TIA Receiver				
Upstream Signal Rate		1.24416			Gb/s	
Optical Center Wavelength	λ	1290	1310	1330	nm	
Receiver Sensitivity	P_{IN}			-28	dBm	1
Receiver Optical Overload	$P_{IN}(SAT)$	-7			dBm	
Damaged Input Optical Power	P_d			-5	dBm	
Receiver Settling Time	Trx			51.2	ns	
Rx_SD Assert	P_A	-45		-30	dBm	
Rx_SD De Assert	P_D	-45		-30	dBm	
Rx_SD Hysteresis	PHy	0		7	dB	

Notes:

1. Test Condition: BER@ 10^{-10} , PRBS $2^{23}-1$, ER=10dB

XGS Time Diagram

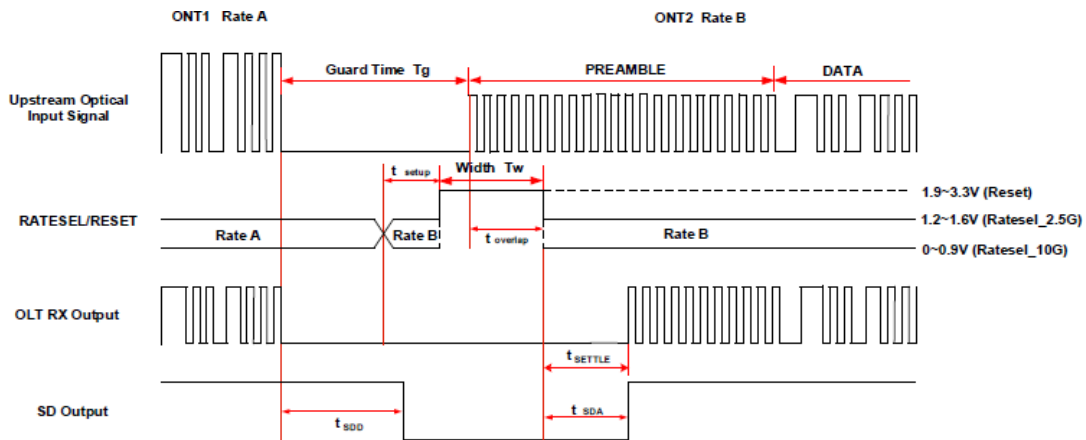

G Time Diagram

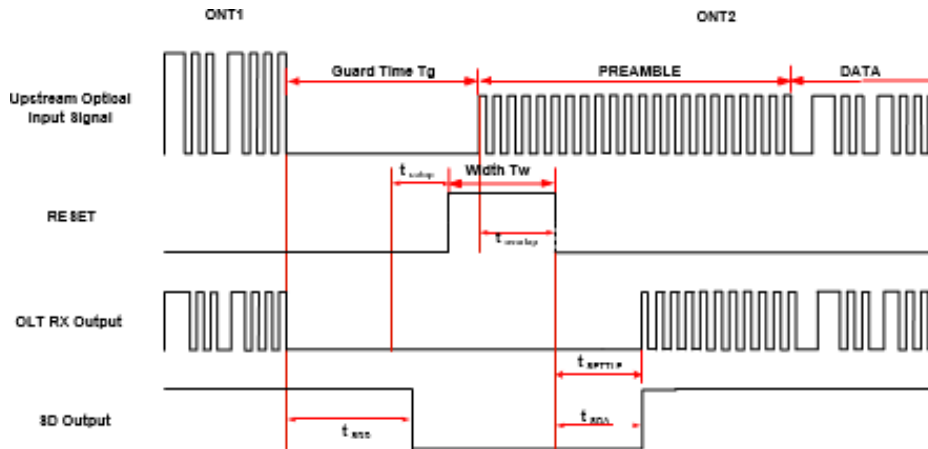

Receiver Timing Diagram

Parameter	Symbol	Min.	Typ.	Max.	Unit	Notes
Guard Time (GPON)	T_g	25.6			ns	
Guard Time (XGS-PON)	T_g	51.2			ns	
Reset Pulse Width (GPON)	T_w	12.8			ns	1
Reset Pulse Width (XGS-PON)	T_w	25.6			ns	1
Reset time overlapping preamble	$t_{overlap}$	0			ns	
Setup time of rate level for following burst	t_{setup}	5			ns	
Burst Signal Detect Assert (GPON)	T_{SDA}			25.6	ns	
Burst Signal Detect Assert (XGS-PON)	T_{SDA}		25	100	ns	
Burst Signal Detect De-assert (GPON)	T_{SDD}			100	ns	2

Burst Signal Detect De-assert (XGS-PON)	T_SDD			100	ns	2
Burst Mode Receiver Setting Time (GPON)	Tsettle			19.2	ns	
Burst Mode Receiver Setting Time (XGS-PON)	Tsettle		100		ns	

Notes:

1. Reset pulse is required to be partially inside preamble.
2. Auto reset function is applied. Signal detect de-assert time is about 100ns forced by auto reset, and will short to about 20ns with external Reset pulse.

Digital RSSI Sample/Hold Timing

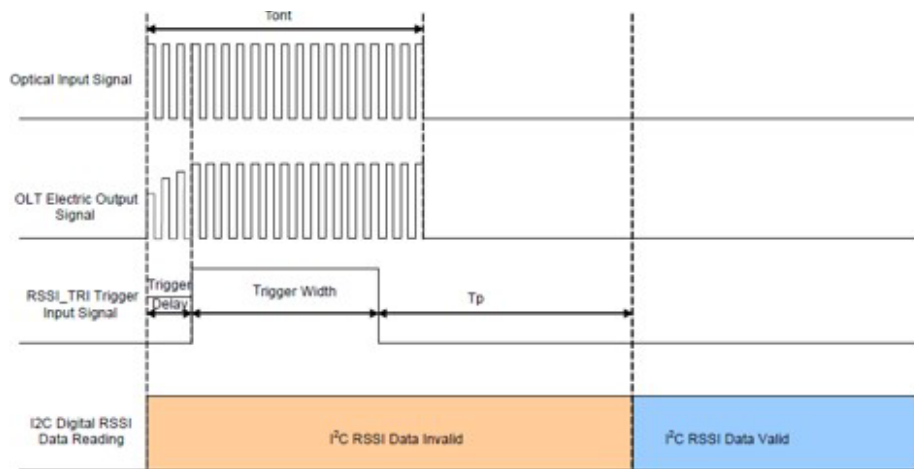

Digital RSSI Sample/Hold Timing

Parameter	Symbol	Min.	Typ.	Max.	Unit	Notes
Optical Input Signal Width	Tont	525			ns	
RSSI Trigger Delay	Ttri (TRI Delay)	25		3000	ns	
RSSI Trigger Width	Ti2c (TRI Width)	500		Tont – Ttri	ns	
I²C Protect Time	Tp	500			μs	
RSSI Monitor Range	Pmon	-6		-30	dBm	
RSSI Precision	Prssi	-3	+/-1	3	dB	
Ttri+Ti2c<Tont						

Pin Descriptions

Pin	Symbol	Name/Descriptions	Ref.
1	GPON_TD+	Transmit Non-Inverted 2.48832Gb/s Data Input; AC coupled inside the module.	
2	GPON_TD-	Transmit Inverted 2.48832Gb/s Data Input; AC coupled inside the module.	
3	GND	Module Ground.	
4	SDA	2-Wire Serial Interface Data Line, with the pull-up resistance: 4.7kΩ~10kΩ.	
5	SCL	2-Wire Serial Interface Clock, with the pull-up resistance: 4.7kΩ~10kΩ.	
6	GPON_RD-	Receive Burst Mode Inverted 1.2488Gb/s Data Output; DC coupled inside the module.	1
7	Ratesel/Reset	Three-level input combining “Rate Select” and “Reset” information. Set high level to reset TIA/LA. Middle level indicates 2.5G data rate. Low level indicates 10G data rate.	
8	XGS-PON_SD	Receiver Signal Detect Indicator for XGS-PON/XGPON Receiver, when Low, indicates insufficient optical input power to the module; when High, means in normal.	
9	Trig/Txdis	Two signals multiplex, which selected by the register. Receiver signal strength indication trigger for Digital RSSI. As TXdisable, when Low level, the transceiver port work in normal; when High level, both 10Gb/s and 2.5Gb/s are disabled.	
10	GPON_RD+	Receive Burst Mode Non-Inverted 1.2488Gb/s Data Output; DC coupled inside the module.	1
11	GND	Module Ground.	
12	XGS-PON_RD-	Receive Burst Mode Inverted 9.953 or 2.48832Gb/s Data Output. DC coupled inside the module.	
13	XGS-PON_RD+	Receive Burst Mode Non-Inverted 9.953 or 2.48832Gb/s Data Output. DC coupled inside the module.	
14	GPON_SD	Receiver Signal Detect Indicator for G-PON Receiver. When Low, indicates insufficient optical input power to the module. When High, means in normal.	
15	VCC3_RX	+3.3V power supply for RX. Tolerance: 3.3V±5%.	
16	VCC3_TX	+3.3V power supply for TX. Tolerance: 3.3V±5%.	
17	GPON_Reset	Burst Mode Receiver Reset for GPON Receiver. When HIGH, indicates the receiver is OFF/being reset.	
18	XGS-PON_TD+	Transmit Non-Inverted 9.95328Gb/s Data Input; AC coupled inside the module.	
19	XGS-PON/_TD-	Transmit Inverted 9.95328Gb/s Data Input; AC coupled inside the module.	
20	GND	Module Ground.	

Notes:

1. When GPON_RD+/- set as LVPECL, and the module without the pull-down resistances. The differential signal amplitude must be satisfied with the Electrical Characteristics.

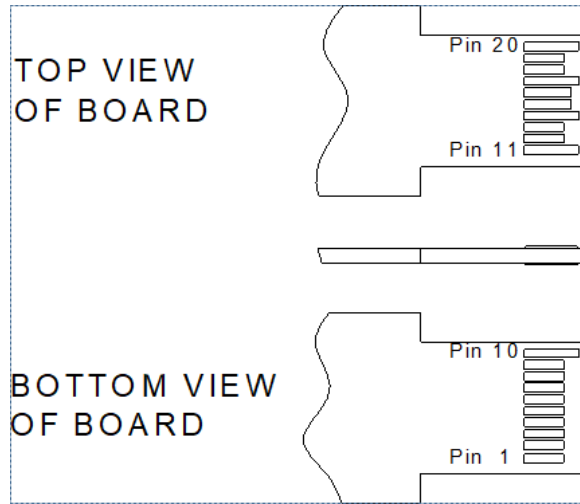

Electrical Interface

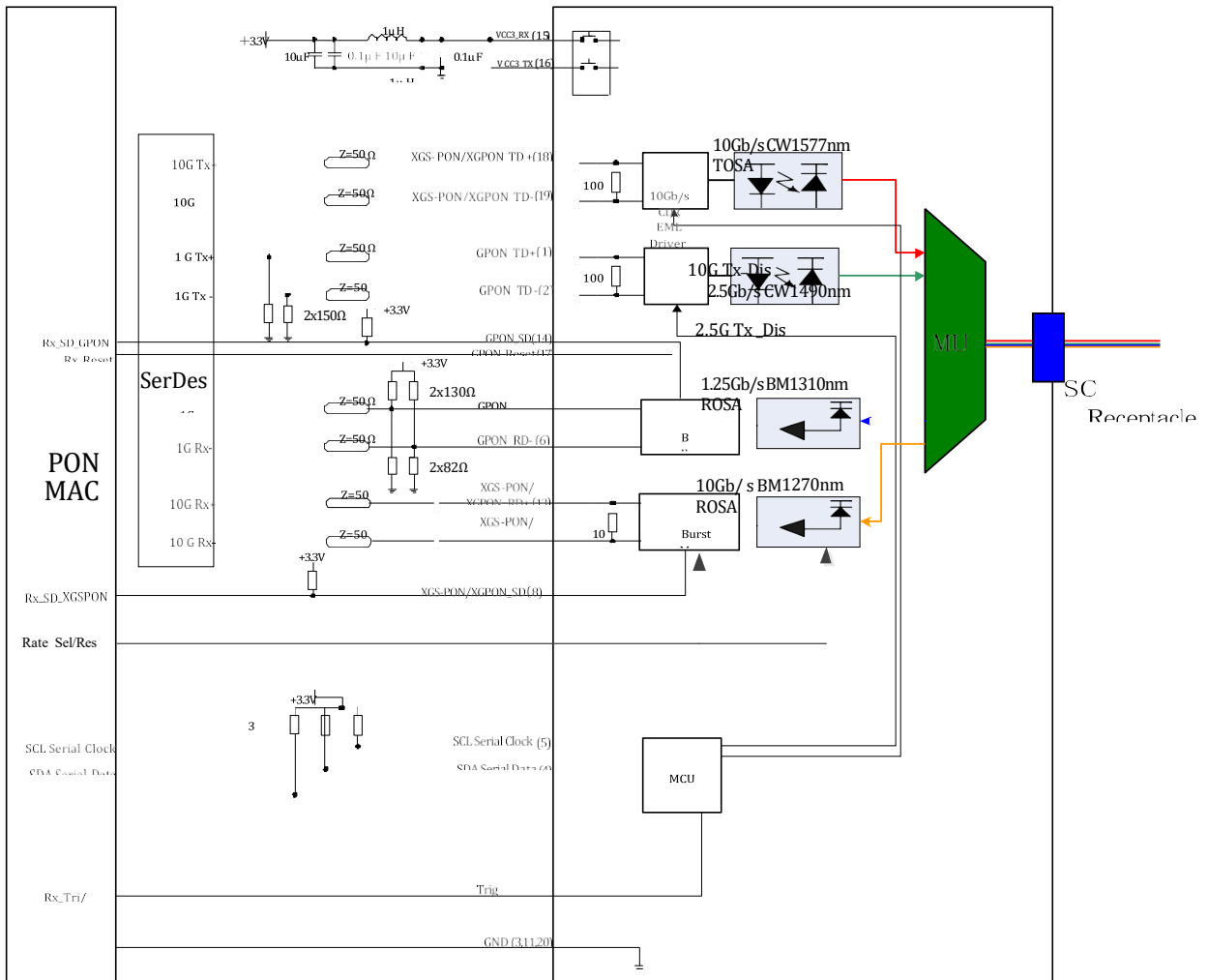

SFP+ Connector Dimensions

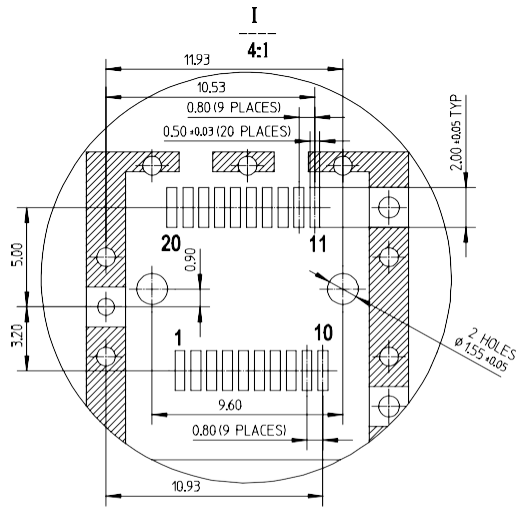

- Notes:**
1. Datum and basic dimensions established by customer
 2. Pads and vias are chassis ground, 11 places
 3. Thru holes, plating optional

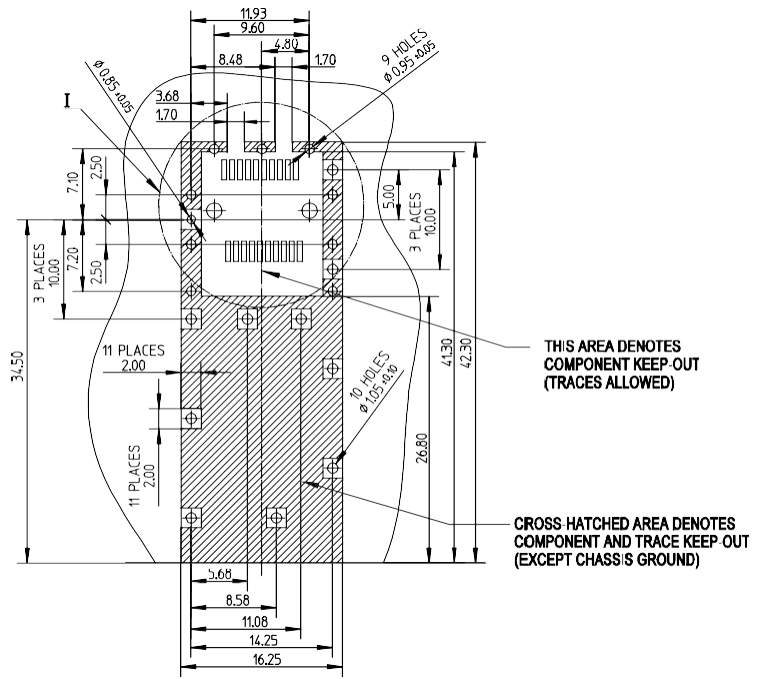

Mechanical Specifications

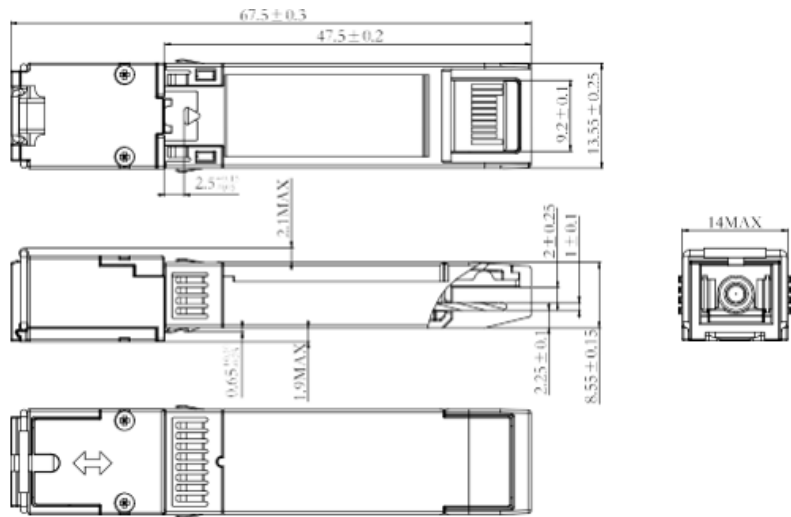

- NOTES:**
1. TOLERANCE: ± 0.1 MM;
 2. OTHERS ACCORDING WITH SFF-8074/SFF-8432 OR CUSTOMER SPEC;
 3. LIGHT PORT ACCORDING WITH FIBER CONNECTOR SPEC.

EEPROM Information

EEPROM memory map specific data field description is as below:

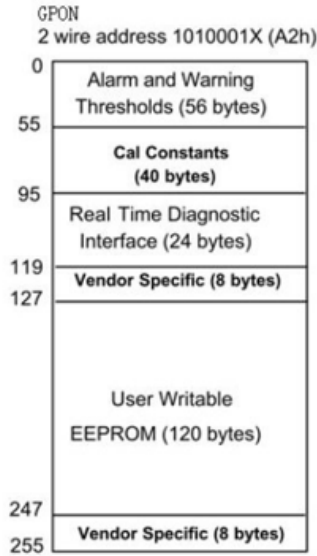
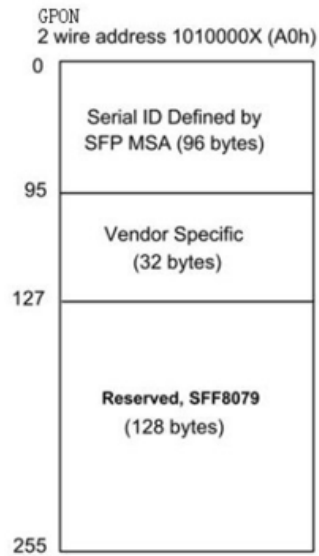
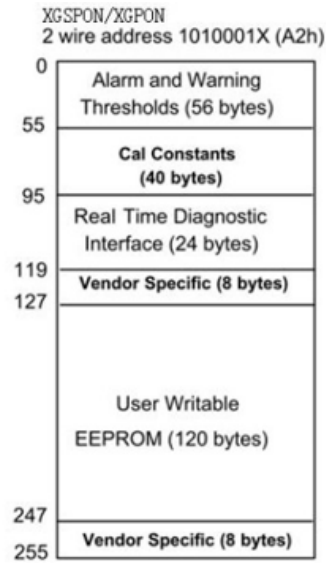
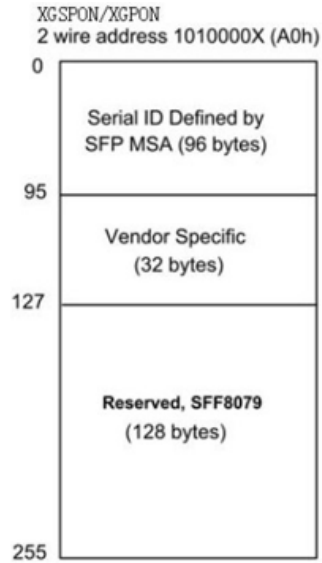

About ProLabs

Our experience comes as standard; for over 15 years ProLabs has delivered optical connectivity solutions that give our customers freedom and choice through our ability to provide seamless interoperability. At the heart of our company is the ability to provide state-of-the-art optical transport and connectivity solutions that are compatible with over 90 optical switching and transport platforms.

Complete Portfolio of Network Solutions

ProLabs is focused on innovations in optical transport and connectivity. The combination of our knowledge of optics and networking equipment enables ProLabs to be your single source for optical transport and connectivity solutions from 100Mb to 400G while providing innovative solutions that increase network efficiency. We provide the optical connectivity expertise that is compatible with and enhances your switching and transport equipment.

Trusted Partner

Customer service is our number one value. ProLabs has invested in people, labs and manufacturing capacity to ensure that you get immediate answers to your questions and compatible product when needed. With Engineering and Manufacturing offices in the U.K. and U.S. augmented by field offices throughout the U.S., U.K. and Asia, ProLabs is able to be our customers best advocate 24 hours a day.



Contact Information

ProLabs US

Email: sales@prolabs.com

Telephone: 952-852-0252

ProLabs UK

Email: salessupport@prolabs.com

Telephone: +44 1285 719 600