

SFP-10GBASE-LRL-I-C

MSA and TAA 10GBase-LR-Lite SFP+ Transceiver (SMF, 1310nm, 2km, LC, DOM, -40 to 85C)

Features:

- Supports from 9.83Gb/s to 11.3Gb/s bit rates
- Compliant with IEEE 802.3ae 10GBASE-LR/LW
- Compliant with 10G FC
- Compliant with SFF-8431
- Hot-pluggable SFP+ footprint
- Duplex LC connector
- Built-in digital diagnostic functions
- Up to 2km on SMF
- Single power supply 3.3V
- Operating Temperature: -40°C to 85°C
- RoHS compliant and Lead Free



Applications:

- 10GBASE-LR/LW Ethernet
- 10GFC

Product Description:

This MSA compliant SFP+ transceiver provides 10GBase-LR throughput up to 2km over single-mode fiber (SMF) using a wavelength of 1310nm via an LC connector. It can operate at temperatures between -40 and 85C. It is built to MSA standards and is uniquely serialized and data-traffic and application tested to ensure that they will integrate into your network seamlessly. It is built to meet or exceed the specifications of MSA, as well as to comply with MSA (Multi-Source Agreement) standards to ensure seamless network integration. This transceiver is Trade Agreements Act (TAA) compliant. We stand behind the quality of our products and proudly offer a limited lifetime warranty.

ProLabs' Transceivers are RoHS compliant and lead-free

TAA refers to the Trade Agreements Act (19 U.S.C. & 2501-2581), which is intended to foster fair and open international trade. TAA requires that the U.S. Government may acquire only "U.S. – made or designated country end products.



Regulatory Compliance

- ESD to the Electrical PINs: compatible with MIL-STD-883E Method 3015.4
- ESD to the LC Receptacle: compatible with IEC 61000-4-3
- EMI/EMC: compatible with FCC Part 15 Subpart B Rules, EN55022:2010
- Laser Eye Safety: compatible with FDA 21CFR, EN60950-1& EN (IEC) 60825-1,2
- RoHS compliant with EU RoHS 2.0 directive 2015/863/EU

Absolute Maximum Ratings

Parameter	Symbol	Min.	Typ.	Max.	Unit	Notes
Maximum Supply Voltage	Vcc	-0.5		4	V	1
Storage Temperature	Tstg	-40		85	°C	2
Operating Case Temperature	Tc	-40		85	°C	3
Data Rate	BR	9.83	10.3125	11.3	Gbps	4
Bit Error Rate	BER			10 ⁻¹²		

Notes:

1. For electrical power interface.
2. Ambient temperature.
3. Case temperature.
4. IEEE 802.3ae.

Link Distances

Data Rate	Fiber Type	Distance Range (km)
9.83 –11.3 Gbps	9/125µm SMF	2

Electrical Characteristics (V_{CC}=3.14-3.46V, T_c=-0°C to 70°C)

Parameter	Symbol	Min.	Typ.	Max.	Unit	Notes
Power Supply Voltage	V _{CC}	3.14	3.30	3.46	V	
Power Supply Current	I _{CC}		230	300	mA	
Transmitter						
Differential Data Input Swing	V _{IN,pp}	180		700	mV	
Input Differential Impedance	R _{IN}		100		Ω	
Transmit Disable Voltage	V _D	2		V _{CC}	V	
Transmit Enable Voltage	V _{EN}	V _{CC}		V _{CC} +0.8	V	
Receiver						
Differential Data Output Swing	V _{OUT,pp}	300		850	mV	
Data Output Rise/Fall Time (20-80%)	T _r /T _f	28			ps	
LOS Assert	LOSA	2		Host_V _{CC}	V	
LOS De-Assert	LOSD	V _{CC}		V _{CC} +0.5	V	

Optical Characteristics

Parameter	Symbol	Min.	Typ.	Max.	Unit	Notes
Transmitter						
Output Optical Power	P _{tx}	-8.2		0.5	dBm	1
Optical Center Wavelength	λ _C	1260	1310	1355	nm	
Optical Modulation Amplitude	OMA	-5.2			dBm	2
Extinction Ratio	ER	3.5			dB	
Side-Mode Suppression Ratio	SMSR	30			dB	
Relative Intensity Noise	RIN			-128	dB/Hz	
Transmitter Dispersion Penalty	TDP			3.2	dB	
Launch Power of Off Transmitter	P _{off}			-30	dBm	1
Receiver						
Optical Center Wavelength	λ _C	1260		1355	nm	
Average Receive Power	P _{rx}	-14.4		0.5	dBm	
Receiver Sensitivity @10.3Gbps	S			-14.4	dBm	3
Receiver Reflectance	R _L			-12	dB	
LOS Assert	LOSA	-30			dBm	
LOS De-Assert	LOSD			-15	dBm	
LOS Hysteresis	LOSH	0.5			dB	

Notes:

1. Average.
2. According to IEEE 802.3ae requirement.
3. Average. Test the resulting value using the minimum ER value within the defined range: $BER < 10^{-12}$ and PRBS $2^{31}-1$.

Pin Descriptions

Pin	Symbol	Name/Descriptions	Ref.
1	VeeT	Transmitter Ground (Common with Receiver Ground).	1
2	Tx_Fault	Transmitter Fault.	2
3	Tx_Disable	Transmitter Disable. Laser output disabled on "high" or "open."	3
4	SDA	2-Wire Serial Interface Data.	4
5	SCL	2-Wire Serial Interface Clock.	4
6	MOD_ABS	Module Absent. Grounded within the module.	4
7	RS0	No connection required.	
8	LOS	Loss of Signal indication. Logic 0 indicates normal operation.	5
9	RS1	No connection required.	1
10	VeeR	Receiver Ground (Common with Transmitter Ground).	1
11	VeeR	Receiver Ground (Common with Transmitter Ground).	1
12	RD-	Receiver Inverted Data Out. AC Coupled.	
13	RD+	Receiver Non-Inverted Data Out. AC Coupled.	
14	VeeR	Receiver Ground (Common with Transmitter Ground).	1
15	VccR	Receiver Power Supply.	
16	VccT	Transmitter Power Supply.	
17	VeeT	Transmitter Ground (Common with Receiver Ground).	1
18	TD+	Transmitter Non-Inverted Data In. AC Coupled.	
19	TD-	Transmitter Inverted Data In. AC Coupled.	
20	VeeT	Transmitter Ground (Common with Receiver Ground).	1

Notes:

1. Circuit ground is isolated from the chassis ground.
2. Tx_Fault is the open collector output and should be pulled up with 4.7k Ω -10k Ω on the host board to a voltage between 2V and Vcc+0.3V.
3. Disabled: $T_{DIS} > 2V$ or open, enabled: $T_{DIS} < 0.8V$.
4. Should be pulled up with 4.7k Ω -10k Ω on the host board to a voltage between 2V and Vcc+0.3V.
5. LOS is an open collector output and should be pulled up with 4.7k Ω -10k Ω on the host board to a voltage between 2V and Vcc+0.3V. The logic "0" indicates normal operation, and the logic "1" indicates that the receiver signal is lost.

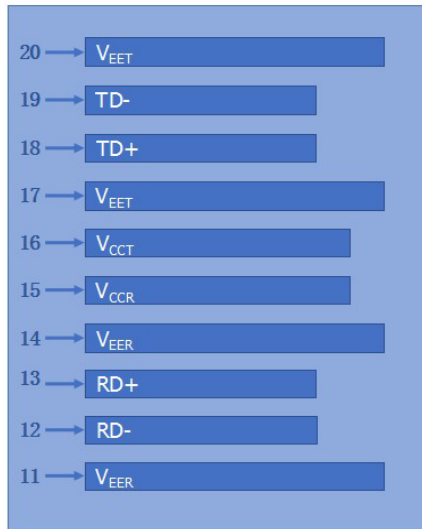

Top of Board

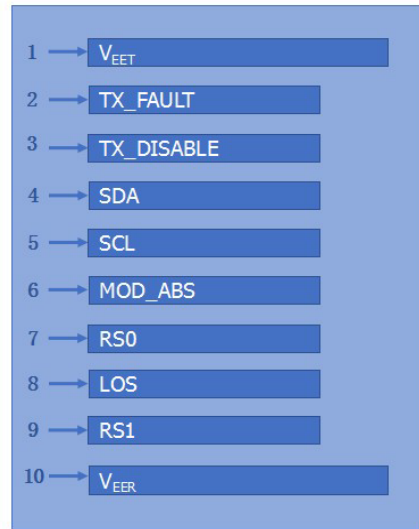

Bottom of Board

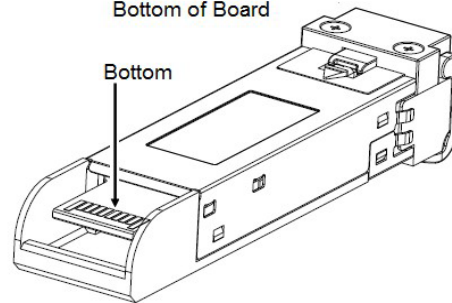
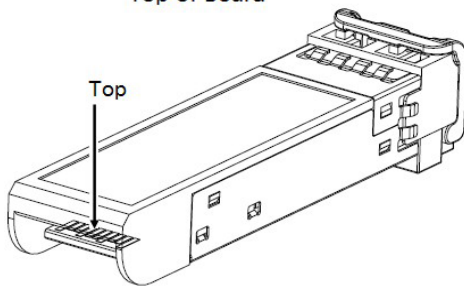

Pin-Out of Connector Block on Host Board

Block Diagram

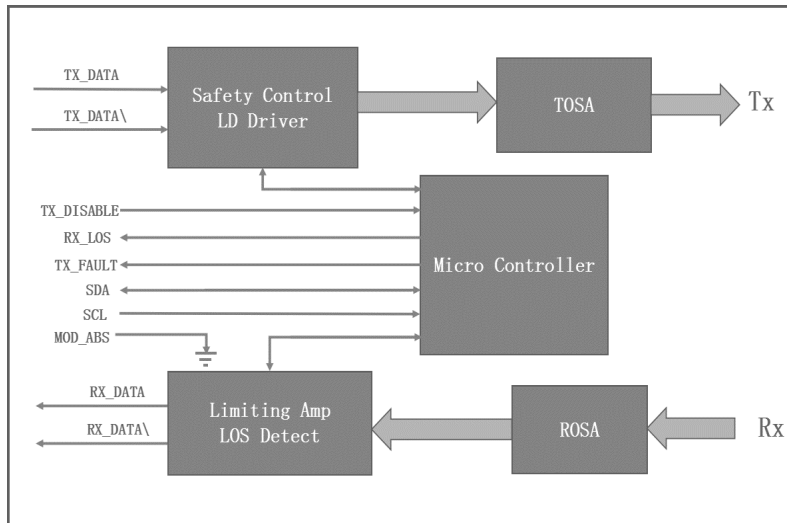

Mechanical Specifications

Small Form Factor Pluggable (SFP) transceivers are compatible with the dimensions defined by the SFP Multi-Sourcing Agreement (MSA).

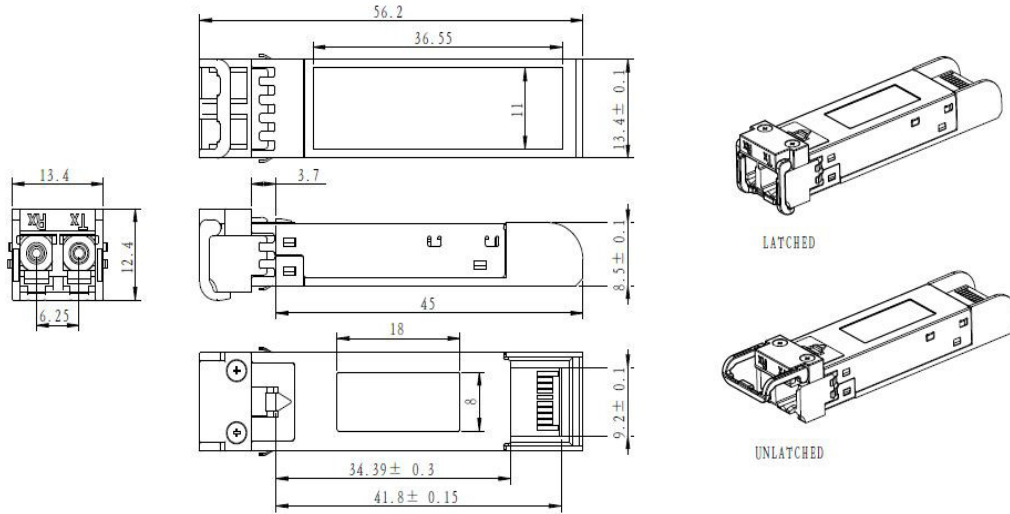

ALL DIMENSIONS ARE ±0.2mm UNLESS THERE IS AN OTHERWISE SPECIFIED UNIT

EEPROM Information

EEPROM memory map specific data field description is as below:

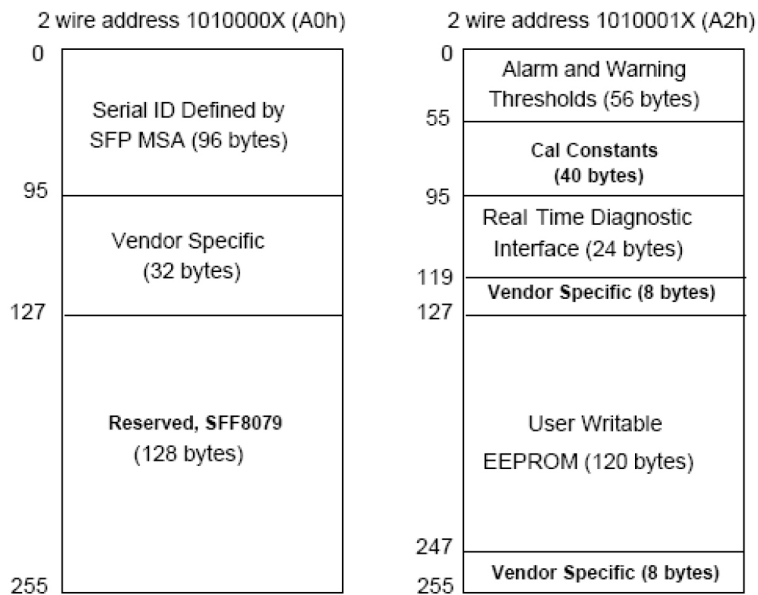

About ProLabs

Our experience comes as standard; for over 15 years ProLabs has delivered optical connectivity solutions that give our customers freedom and choice through our ability to provide seamless interoperability. At the heart of our company is the ability to provide state-of-the-art optical transport and connectivity solutions that are compatible with over 90 optical switching and transport platforms.

Complete Portfolio of Network Solutions

ProLabs is focused on innovations in optical transport and connectivity. The combination of our knowledge of optics and networking equipment enables ProLabs to be your single source for optical transport and connectivity solutions from 100Mb to 400G while providing innovative solutions that increase network efficiency. We provide the optical connectivity expertise that is compatible with and enhances your switching and transport equipment.

Trusted Partner

Customer service is our number one value. ProLabs has invested in people, labs and manufacturing capacity to ensure that you get immediate answers to your questions and compatible product when needed. With Engineering and Manufacturing offices in the U.K. and U.S. augmented by field offices throughout the U.S., U.K. and Asia, ProLabs is able to be our customers best advocate 24 hours a day.

Contact Information

ProLabs US

Email: sales@prolabs.com

Telephone: 952-852-0252

ProLabs UK

Email: salesupport@prolabs.com

Telephone: +44 1285 719 600