

### **ADD-16FMPOF-LB-OM3-3DB**

16-fiber MPO to MPO Loopback OM3 with 3DB attenuator housing

#### **Features**

- Fiber Optic MPO Adapter
- OM3 Loopback
- MPO-16 Female Connectors
- With a 3dB Attenuator
- Channel Loss:  $3\pm 0.5\text{dB}$
- Return Loss:  $\geq 20\text{dB}$

#### **Product Description**

This is a 16-fiber MPO loopback connector with a 3db attenuator. This is made from OM3 cable which has a core size of 50 microns that supports 10 Gigabit Ethernet at lengths measuring up to 300 meters, and 40 Gigabit or 100 Gigabit Ethernet measuring up to 100 meters. This adapter is best suited for fiber testing. Our patch cables are 100% compliant for all of your networking needs. Our products are guaranteed by federal law to not affect or void OEM warranties.

## Mechanical Specifications

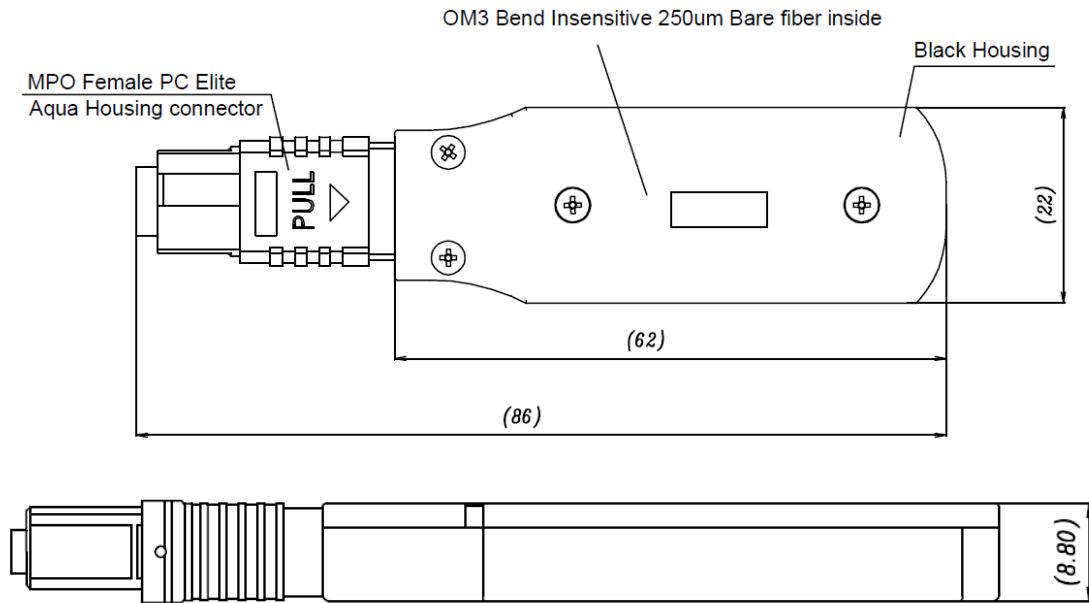

### Fiber Chart:

250um Fiber Colors	MPO Channel	
Blue	Channel 1	Channel 16
Orange	Channel 2	Channel 15
Green	Channel 3	Channel 14
Brown	Channel 4	Channel 13
Slate	Channel 5	Channel 12
White	Channel 6	Channel 11
Red	Channel 7	Channel 10
Black	Channel 8	Channel 9

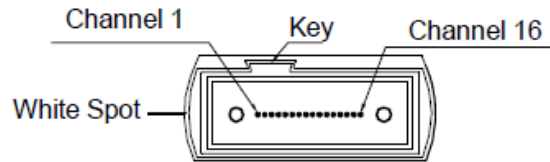
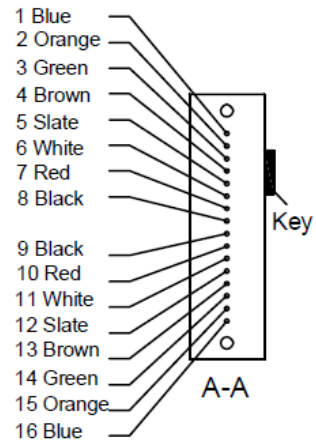

MPO 16F Channel Definition (Front View A-A)

## About AddOn Networks

In 1999, AddOn Networks entered the market with a single product. Our founders fulfilled a severe shortage for compatible, cost-effective optical transceivers that compete at the same performance levels as leading OEM manufacturers. Adhering to the idea of redefining service and product quality not previously had in the fiber optic networking industry, AddOn invested resources in solution design, production, fulfillment, and global support.

Combining one of the most extensive and stringent testing processes in the industry, an exceptional free tech support center, and a consistent roll-out of innovative technologies, AddOn has continually set industry standards of quality and reliability throughout its history.

Reliability is the cornerstone of any optical fiber network and is engrained in AddOn's DNA. It has played a key role in nurturing the long-term relationships developed over the years with customers. AddOn remains committed to exceeding industry standards with certifications from ranging from NEBS Level 3 to ISO 9001:2005 with every new development while maintaining the signature reliability of its products.



## U.S. Headquarters

Email: [sales@addonnetworks.com](mailto:sales@addonnetworks.com)

Telephone: +1 877.292.1701

Fax: 949.266.9273

## Europe Headquarters

Email: [salesupportemea@addonnetworks.com](mailto:salesupportemea@addonnetworks.com)

Telephone: +44 1285 842070