

ADD-LC-LC-OS2-LB

LC to LC Loopback OS2 with housing

Features

- LC to LC Loopback
- Insertion Loss: $\leq 0.60\text{dB}$

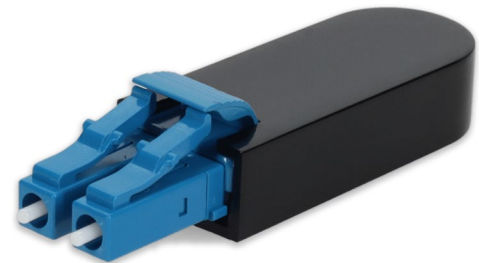

Product Description

This is a LC duplex loopback connector. This is made from OS2, which is a standard single-mode optical fiber commonly used with wavelengths of 1310nm and 1550nm (9/125 microns), and has a maximum attenuation of 1dB/km. The OS2 standard is defined in ISO/IEC 11801. This adapter is best suited for fiber testing. Our patch cables are 100% compliant for all of your networking needs. Our products are guaranteed by federal law to not affect or void OEM warranties.

Mechanical Specifications

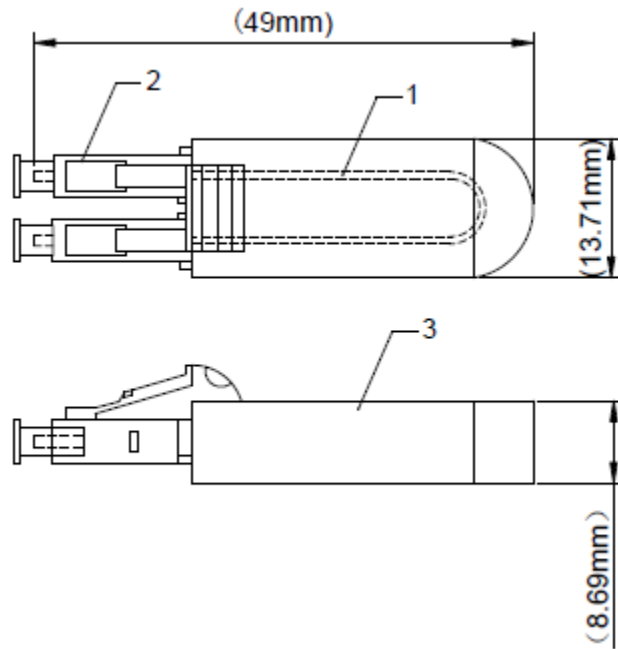

Item	QTY	Description
1	A/R	OD:025mm, Single-mode 9/125 G657A2, Simplex, Color: Transparent
2	1	LC/UPC SM Duplex 2.0mm Connector (Blue Housing)
3	1	Plastic Housing

About AddOn Networks

In 1999, AddOn Networks entered the market with a single product. Our founders fulfilled a severe shortage for compatible, cost-effective optical transceivers that compete at the same performance levels as leading OEM manufacturers. Adhering to the idea of redefining service and product quality not previously had in the fiber optic networking industry, AddOn invested resources in solution design, production, fulfillment, and global support.

Combining one of the most extensive and stringent testing processes in the industry, an exceptional free tech support center, and a consistent roll-out of innovative technologies, AddOn has continually set industry standards of quality and reliability throughout its history.

Reliability is the cornerstone of any optical fiber network and is engrained in AddOn's DNA. It has played a key role in nurturing the long-term relationships developed over the years with customers. AddOn remains committed to exceeding industry standards with certifications from ranging from NEBS Level 3 to ISO 9001:2005 with every new development while maintaining the signature reliability of its products.



U.S. Headquarters

Email: sales@addonnetworks.com

Telephone: +1 877.292.1701

Fax: 949.266.9273

Europe Headquarters

Email: salesupportemea@addonnetworks.com

Telephone: +44 1285 842070