

## QSFP28-OTU4-ER4L-AO

MSA and TAA Compliant OTU-4-ER4L 100GbE Dual-Rate QSFP28 Transceiver (SMF, 1295nm to 1309nm, 40km w/host FEC, LC, DOM)

### Features:

- Supports 103.1Gb/s and 112Gb/s aggregate bit rates
- Compliant with QSFP28 MSA
- Compliant with IEEE 802.3ba, IEEE 802.3bm
- 4x25G Electrical Serial Interface
- Built in digital diagnostic function
- Transmitter: cooled 4x25Gb/s LAN WDM DML TOSA
- Receiver: 4x25Gb/s APD ROSA
- Single +3.3V power supply
- Class 1 laser safety certified
- Power dissipation <4.5W
- Operating temperature: 0°C to 70°C
- Up to 30km on SMF without FEC/ 40km with FEC
- Duplex LC Connector
- RoHS 6/6 Compliant

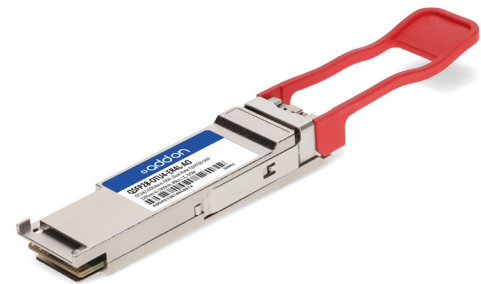

### Applications:

- 100G BASE-ER4 & OTU4
- Infiniband QDR and DDR interconnects
- 100G Datacom connections

### Product Description

This MSA compliant QSFP28 transceiver provides OTU-4-ER4 100GbE Dual-Rate ER4L throughput up to 40km over single-mode fiber (SMF) using a wavelength of 1295nm to 1309nm via an LC connector. It is built to MSA standards and is uniquely serialized and data-traffic and application tested to ensure that they will integrate into your network seamlessly. Digital optical monitoring (DOM) support is also present to allow access to real-time operating parameters. This transceiver is Trade Agreements Act (TAA) compliant. We stand behind the quality of our products and proudly offer a limited lifetime warranty.

AddOn's Transceivers are RoHS compliant and lead-free.

TAA refers to the Trade Agreements Act (19 U.S.C. & 2501-2581), which is intended to foster fair and open international trade. TAA requires that the U.S. Government may acquire only "U.S. – made or designated country end products."



## Regulatory Compliance

- ESD to the Electrical PINs: compatible with MIL-STD-883E Method 3015.4
- ESD to the LC Receptacle: compatible with IEC 61000-4-3
- EMI/EMC compatible with FCC Part 15 Subpart B Rules, EN55022:2010
- Laser Eye Safety compatible with FDA 21CFR, EN60950-1& EN (IEC) 60825-1,2
- RoHS compliant with EU RoHS 2.0 directive 2015/863/EU

## Absolute Maximum Ratings

Parameter	Symbol	Min.	Typ.	Max.	Unit
Maximum Supply Voltage	Vcc	-0.5		3.6	V
Storage Temperature	TS	-40		85	°C
Operating Case Temperature	Tc	0		70	°C
Operating Relative Humidity	RH	5		85	%
Rx Damage Threshold, per Lane	PRdmg	-3.0			dBm
Data Rate	DR		103.125		Gb/s
Link Distance with G.652 (without FEC)	D1			30	km
Link Distance with G.652 (with FEC)	D2			40	km

## Electrical Characteristics

Parameter	Symbol	Min.	Typ.	Max.	Unit	Notes
Supply Voltage	Vcc	3.14	3.3	3.47	V	
Supply Current	Icc			1.36	A	
Power Consumption	P			4.5	W	
<b>Transmitter</b>						
Input differential impedance	Rin		100		Ω	1
Differential data input swing	Vin,pp	180		1000	mV	
Transmit Disable Voltage	VD	Vcc-1.3		Vcc	V	
Transmit Enable Voltage	VEN	Vee		Vee+ 0.8	V	2
<b>Receiver</b>						
Differential data output swing	Vout,pp	300		850	mV	3
LOS Fault	VLOS fault	Vcc-1.3		VccHOST	V	4
LOS Normal	VLOS norm	Vee		Vee+0.8	V	4

## Notes:

1. Connected directly to TX data input pins. AC coupled thereafter.

2. Optional for TX disable
3. Into 100 ohms differential termination
4. Loss Of Signal is LVTTTL. Logic 0 indicates normal operation; logic 1 indicates no signal detected

## Optical Characteristics

Parameter	Symbol	Min.	Typ.	Max.	Unit	Notes
<b>Transmitter</b>						
Signaling rate, each lane	DRPL	25.78125 ±100 ppm			Gb/s	
Four Lane Wavelength Range	λ1	1294.53	1295.56	1296.59	nm	
	λ2	1299.02	1300.05	1301.09	nm	
	λ3	1303.54	1304.58	1305.63	nm	
	λ4	1308.09	1309.14	1310.19	nm	
Total launch power	Pout			12.5	dBm	
Average launch power, each lane	Pavg	-2.5		6.5	dBm	
Optical modulation amplitude, each lane (OMA)	OMA	0.5		6.5	dBm	
Extinction ratio	ER	4.5			dB	
Side-mode suppression ratio	SMSR	30			dB	
Average launch power of OFF transmitter, per lane	POFF			-30	dBm	
RIN	RIN			-130	dB/Hz	
Transmitter reflectance	TR			-12	dB	
Transmitter eye mask {X1, X2, X3, Y1, Y2, Y3}	Mt	{0.25, 0.4, 0.45, 0.25, 0.28, 0.4}				1
<b>Receiver</b>						
Four Lane Wavelength Range	λ1	1294.53	1295.56	1296.59	nm	
	λ2	1299.02	1300.05	1301.09	nm	
	λ3	1303.54	1304.58	1305.63	nm	
	λ4	1308.09	1309.14	1310.19	nm	
Receive Rate for Each Lane	Pavg	25.78125 ±100 ppm			Gb/s	
Damage Threshold, each Lane	THd			-7	dBm	
Average receive power, each lane (max)	PSAT			-7	dBm	
Average receive power, each lane (min)	Pin			-18.5	dBm	2
Average receive power, each lane (min)	Pin			-14.5	dBm	3
Return Loss	RL			-26	dB	
Los De-Assert	Pd			-23	dBm	
Los Assert	Pa	-33			dBm	

Loss Hysteresis	Pd-Pa	0.5		6	dBm	
-----------------	-------	-----	--	---	-----	--

**Notes:**

1. Hit ratio  $5 \times 10^{-5}$
2. BER =  $5 \times 10^{-5,2}$
3. BER =  $1 \times 10^{-12,2}$

**Electrical Pin-out Details**

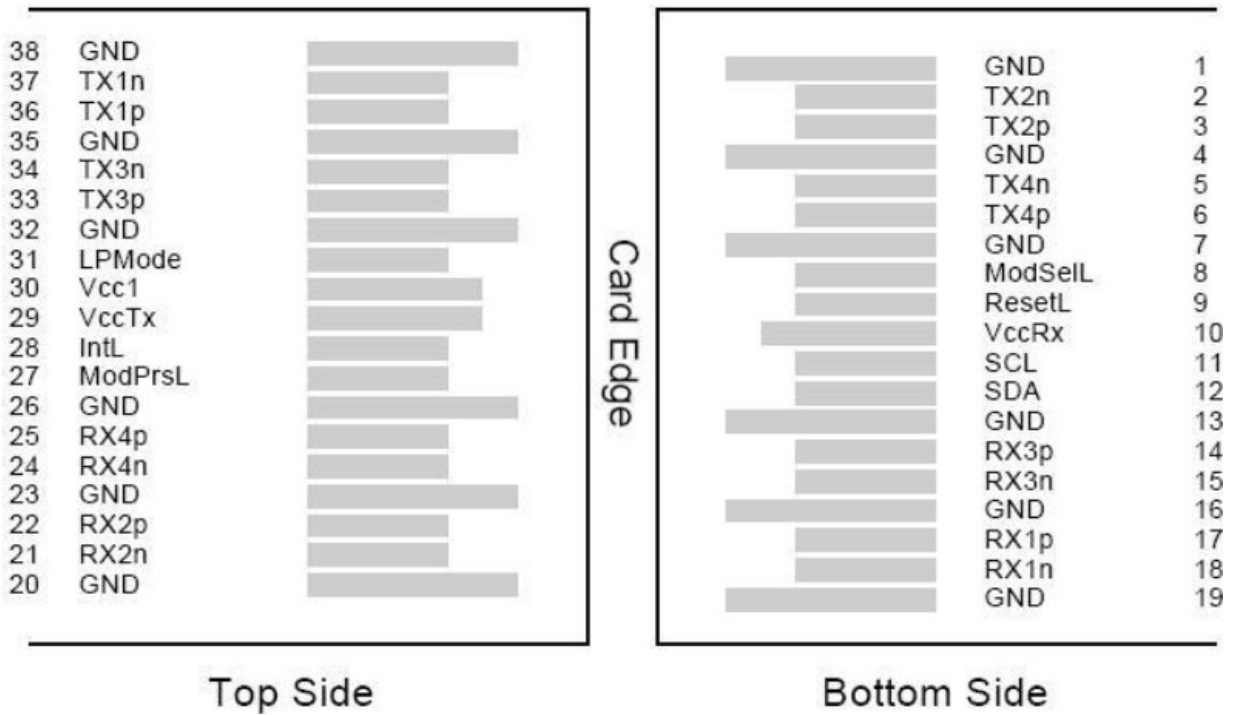

## Pin Descriptions

Pin	Symbol	Name/Descriptions	Ref.
1	GND	Transmitter Ground (Common with Receiver Ground)	1
2	Tx2-	Transmitter Inverted Data Input	
3	Tx2+	Transmitter Non-Inverted Data output	
4	GND	Transmitter Ground (Common with Receiver Ground)	1
5	Tx4-	Transmitter Inverted Data Input	
6	Tx4+	Transmitter Non-Inverted Data output	
7	GND	Transmitter Ground (Common with Receiver Ground)	1
8	ModSelL	Module Select	2
9	ResetL	Module Reset	2
10	VccRx	3.3V Power Supply Receiver	
11	SCL	2-Wire serial Interface Clock	2
12	SDA	2-Wire serial Interface Data	2
13	GND	Transmitter Ground (Common with Receiver Ground)	1
14	Rx3+	Receiver Non-Inverted Data Output	
15	Rx3-	Receiver Inverted Data Output	
16	GND	Transmitter Ground (Common with Receiver Ground)	1
17	Rx1+	Receiver Non-Inverted Data Output	
18	Rx1-	Receiver Inverted Data Output	
19	GND	Transmitter Ground (Common with Receiver Ground)	1
20	GND	Transmitter Ground (Common with Receiver Ground)	1
21	Rx2-	Receiver Inverted Data Output	
22	Rx2+	Receiver Non-Inverted Data Output	
23	GND	Transmitter Ground (Common with Receiver Ground)	1
24	Rx4-	Receiver Inverted Data Output	1
25	Rx4+	Receiver Non-Inverted Data Output	
26	GND	Transmitter Ground (Common with Receiver Ground)	1
27	ModPrsl	Module Present	
28	IntL	Interrupt	2
29	VccTx	3.3V power supply transmitter	
30	Vcc1	3.3V power supply	
31	LPMODE	Low Power Mode	2
32	GND	Transmitter Ground (Common with Receiver Ground)	1
33	Tx3+	Transmitter Non-Inverted Data Input	
34	Tx3-	Transmitter Inverted Data Output	

35	GND	Transmitter Ground (Common with Receiver Ground)	1
36	Tx1+	Transmitter Non-Inverted Data Input	
37	Tx1-	Transmitter Inverted Data Output	
38	GND	Transmitter Ground (Common with Receiver Ground)	1

**Notes:**

1. The module signal grounds are isolated from the module case.
2. This is an open collector/drain output that on the host board requires a 4.7KΩ to 10KΩ pull-up resistor to VccHost.

**Recommended Power Supply Filter Network**

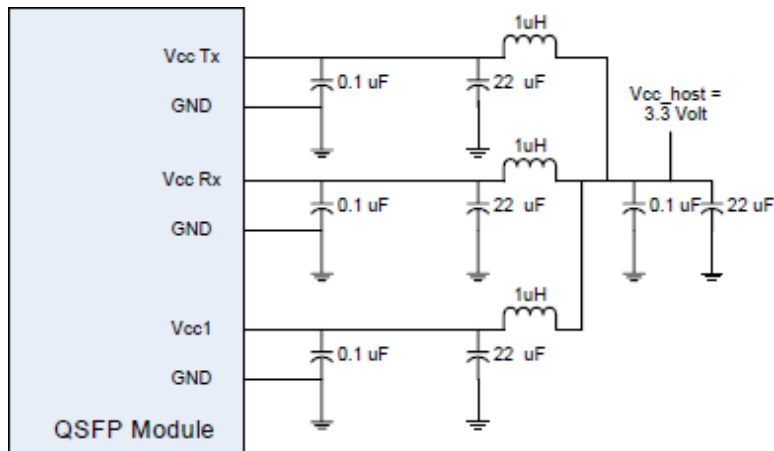

**Functional Diagram**

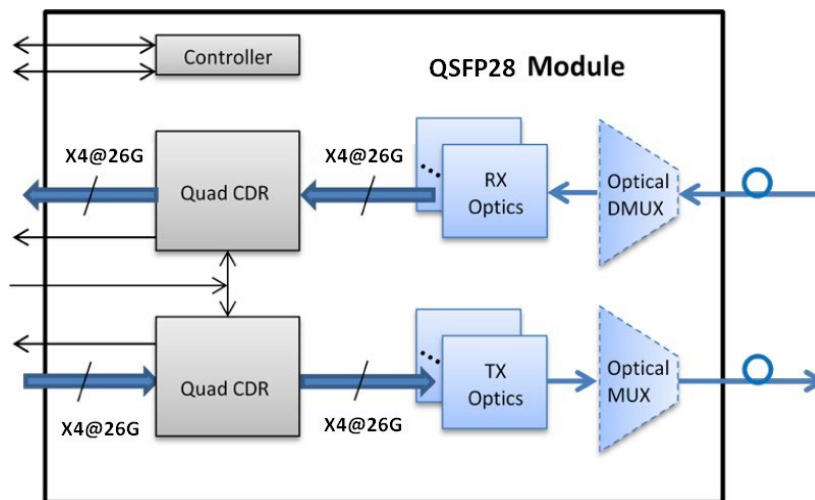

# Mechanical Specifications

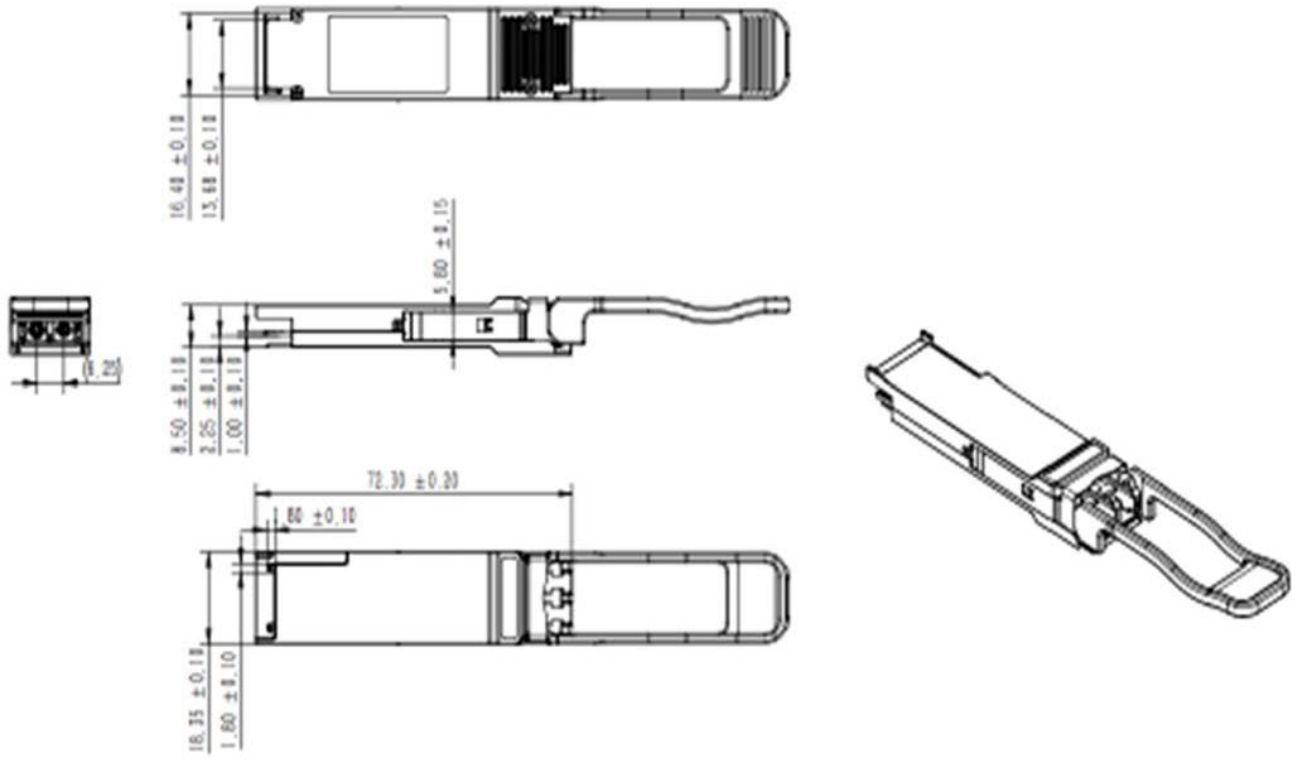

## **About AddOn Networks**

In 1999, AddOn Networks entered the market with a single product. Our founders fulfilled a severe shortage for compatible, cost-effective optical transceivers that compete at the same performance levels as leading OEM manufacturers. Adhering to the idea of redefining service and product quality not previously had in the fiber optic networking industry, AddOn invested resources in solution design, production, fulfillment, and global support.

Combining one of the most extensive and stringent testing processes in the industry, an exceptional free tech support center, and a consistent roll-out of innovative technologies, AddOn has continually set industry standards of quality and reliability throughout its history.

Reliability is the cornerstone of any optical fiber network and is engrained in AddOn's DNA. It has played a key role in nurturing the long-term relationships developed over the years with customers. AddOn remains committed to exceeding industry standards with certifications from ranging from NEBS Level 3 to ISO 9001:2005 with every new development while maintaining the signature reliability of its products.

## **U.S. Headquarters**

Email: [sales@addonnetworks.com](mailto:sales@addonnetworks.com)

Telephone: +1 877.292.1701

Fax: 949.266.9273

## **Europe Headquarters**

Email: [salesupportemea@addonnetworks.com](mailto:salesupportemea@addonnetworks.com)

Telephone: +44 1285 842070