

SFP-25GB-DW-C-15-E-AO

MSA and TAA 10/25GBase-DWDM SFP28 Transceiver Dual-Rate 100GHz (SMF, Tunable, 15km, LC, DOM, -20 to 85C)

Features

- SFF-8432 and SFF-8472 Compliant
- 100GHz Channel Spacing
- Duplex LC Connector
- Extended Temperature -20 to 85 Celsius
- Single-mode Fiber
- Supports 24.33024G, 25.78125Gbps (with FEC); 9.8304G, 10.1376G, 10.3125Gbps
- Excellent ESD Protection
- Hot Pluggable
- RoHS Compliant and Lead Free
- Metal with Lower EMI



Applications

- 25GBase
- Access, Metro and Enterprise

Product Description

This MSA Compliant SFP28 transceiver provides 10/25GBase-DWDM throughput up to 15km over single-mode fiber (SMF) using a tunable wavelength via an LC connector. It is built to MSA standards and is uniquely serialized and data-traffic and application tested to ensure that they will integrate into your network seamlessly. Digital optical monitoring (DOM) support is also present to allow access to real-time operating parameters. This transceiver is Trade Agreements Act (TAA) compliant. We stand behind the quality of our products and proudly offer a limited lifetime warranty.

AddOn's transceivers are RoHS compliant and lead-free.

TAA refers to the Trade Agreements Act (19 U.S.C. & 2501-2581), which is intended to foster fair and open international trade. TAA requires that the U.S. Government may acquire only "U.S. – made or designated country end products."



Regulatory Compliance

- ESD to the Electrical PINs: compatible with MIL-STD-883E Method 3015.4.
- ESD to the LC Receptacle: compatible with IEC 61000-4-3.
- EMI/EMC: compatible with FCC Part 15 Subpart B Rules, EN55022:2010.
- Laser Eye Safety: compatible with FDA 21CFR, EN60950-1& EN (IEC) 60825-1, 2.
- RoHS: compliant with EU RoHS 2.0 directive 2015/863/EU.

DWDM Wavelength ITU Channels - 100 GHz Spacing

ITU Channel	Center Wavelength (nm)	Frequency (THz)	ITU Channel	Center Wavelength (nm)	Frequency (THz)
14	1566.31	191.4	38	1546.92	193.8
15	1565.50	191.5	39	1546.12	193.9
16	1564.68	191.6	40	1545.32	194.0
17	1563.86	191.7	41	1544.53	194.1
18	1563.05	191.8	42	1543.73	194.2
19	1562.23	191.9	43	1542.94	194.3
20	1561.42	192.0	44	1542.14	194.4
21	1560.61	192.1	45	1541.35	194.5
22	1559.79	192.2	46	1540.56	194.6
23	1558.98	192.3	47	1539.77	194.7
24	1558.17	192.4	48	1538.98	194.8
25	1557.36	192.5	49	1538.19	194.9
26	1556.55	192.6	50	1537.4	195.0
27	1555.75	192.7	51	1536.61	195.1
28	1554.94	192.8	52	1535.82	195.2
29	1554.13	192.9	53	1535.04	195.3
30	1553.33	193.0	54	1534.25	195.4
31	1552.52	193.1	55	1533.47	195.5
32	1551.72	193.2	56	1532.68	195.6
33	1550.92	193.3	57	1531.9	195.7
34	1550.12	193.4	58	1531.12	195.8
35	1549.32	193.5	59	1530.33	195.9
36	1548.51	193.6	60	1529.55	196.0
37	1547.72	193.7	61	1528.77	196.1

Absolute Maximum Ratings

Parameter	Symbol	Min.	Typ.	Max.	Unit
Maximum Supply Voltage	Vcc	0	3.3	3.6	V
Storage Temperature	Tstg	-40		85	°C
Operating Case Temperature	Tc	-20		85	°C
Operating Humidity	RH	0		85	%
Data Rate	DR	24.33024 9.8304		25.78125 10.3125	Gbps
Data Rate Accuracy		-100		100	ppm
9/125µm G.652 SMF				15	km

Electrical Characteristics

Parameter	Symbol	Min.	Typ.	Max.	Unit	Notes
Power Supply Voltage	Vcc	3.135	3.30	3.465	V	
Power Dissipation	P _{DISS}			2.5	W	1
Power Supply Current	I _{CC}			0.76	A	
Transmitter						
Data Rate	DR	24.33024 9.8304		25.78125 10.3125	Gbps	CDR Bypass
Differential Voltage pk-pk	V _{IN,pp}	180		900	mV	
Tx Differential Input Impedence	Z _{IN}		100		Ω	
Transmitter Disable Voltage	V _D	2		V _{ee} + 0.3	V	
Transmitter Enable Voltage	V _{EN}	0		0.8	V	
Receiver						
Data Rate	DR	24.33024 9.8304		25.78125 10.3125	Gbps	CDR Bypass
Differential Voltage pk-pk	V _{IN,pp}	450	600	900	mV	
Rx Differential Output Impedence	Z _{OUT}		100		Ω	
LOS Assert Voltage	V _{LOSA}	2.4		V _{cc}	V	
LOS De-Assert Voltage	V _{LOSD}	V _{ee}		V _{ee} +0.4	V	
Eye Height	EH ₁₅	228			mV	
Eye Width	EW ₁₅	0.57			UI	
Vertical Eye Closure	VEC			5.5	dB	

Notes:

- Power dissipation is less than 2.5W when supply voltage is 3.3V.

Optical Characteristics

Parameter	Symbol	Min.	Typ.	Max.	Unit	Notes
Transmitter						
Output Average Power	PO	0		4	dBm	
Wavelength Range	λ_C	1528.77		1566.31	nm	
Wavelength Accuracy		-12.5		12.5	GHz	
Frequency Range		191.3		196.0	THz	
Channel Spacing			100		GHz	
Extinction Ratio	ER	3.5			dB	
Side-Mode Suppression Ratio	SMSR	30			dB	
Transmitter Eye Mask Definition {X1, X2, X3, Y1, Y2, Y3}		{0.31, 0.4, 0.45, 0.34, 0.38, 0.4} Hit ratio 5×10^{-5} hits per sample				
Receiver						
Frequency Range		191.3		196.0	THz	
Saturation Power		-2		-23	dBm	
Receiver Sensitivity	S			-14 ($5e^{-5}$ FEC)	dBm	
Receiver Sensitivity (After 15km)	S			-14 ($5e^{-5}$ FEC)	dBm	
LOS Assert	LOSA	-30			dBm	
LOS De-Assert	LOSD			-16	dBm	
LOS Hysteresis		0.5			dB	
SRS Eye Mask Definition {X1, X2, X3, Y1, Y2, Y3}		{0.31, 0.4, 0.45, 0.34, 0.38, 0.4}				

Pin Descriptions

Pin	Symbol	Name	Ref.
1	VeeT	Transmitter Ground.	1
2	Tx_Fault	Transmitter Fault Indication.	
3	Tx_Disable	Disables the transmitter or laser output.	2
4	SDA	2-Wire Serial Interface Data.	2
5	SCL	2-Wire Serial Interface Clock.	2
6	Mod_ABS	Indicates the module online state. This pin is connected to the VeeT or VeeR pin.	
7	RS0	Selects a rate for the module. This pin is connected to the 33kΩ resistor.	
8	LOS	Indicates a loss of received signals.	2
9	RS1	Selects a rate for the module. This pin is connected to the 33kΩ resistor.	
10	VeeR	Receiver Ground.	1
11	VeeR	Receiver Ground 1.	1
12	RD-	Inverse Received Data Output.	
13	RD+	Received Data Output.	
14	VeeR	Receiver Ground.	1
15	VccR	+3.3V Receiver Power.	1
16	VccT	+3.3V Transmitter Power.	1
17	VeeT	Transmitter Ground.	1
18	TD+	Transmit Data Input.	
19	TD-	Inverse Transmit Data Input.	
20	VeeT	Transmitter Ground.	1

Notes:

1. The ground of the module (operating module ground) and that of the module shell are separate from each other.
2. 4.7kΩ–10kΩ resistor is used on the module to pull the output up to 3.15–3.45V.



Pin-Out of Connector Block on Host Board

Transceiver Block Diagram

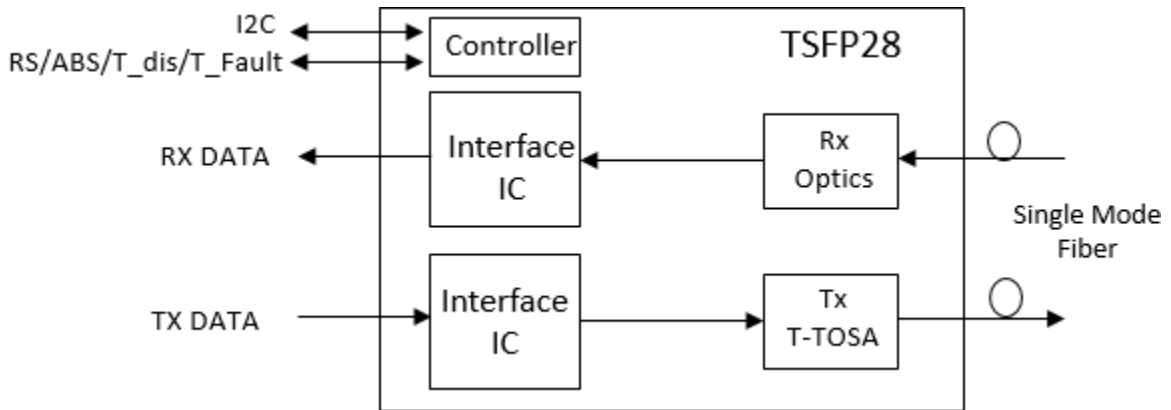

Mechanical Specifications

Small Form Factor Pluggable (SFP) transceivers are compatible with the dimensions defined by the SFP Multi-Sourcing Agreement (MSA).

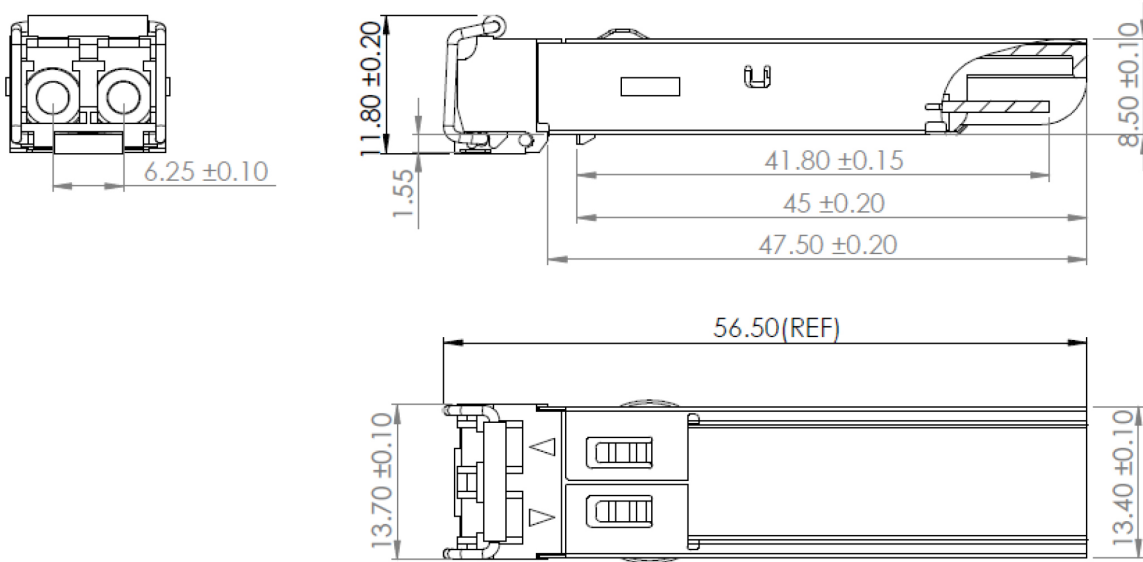

EEPROM Information

EEPROM memory map-specific data field description is as below:

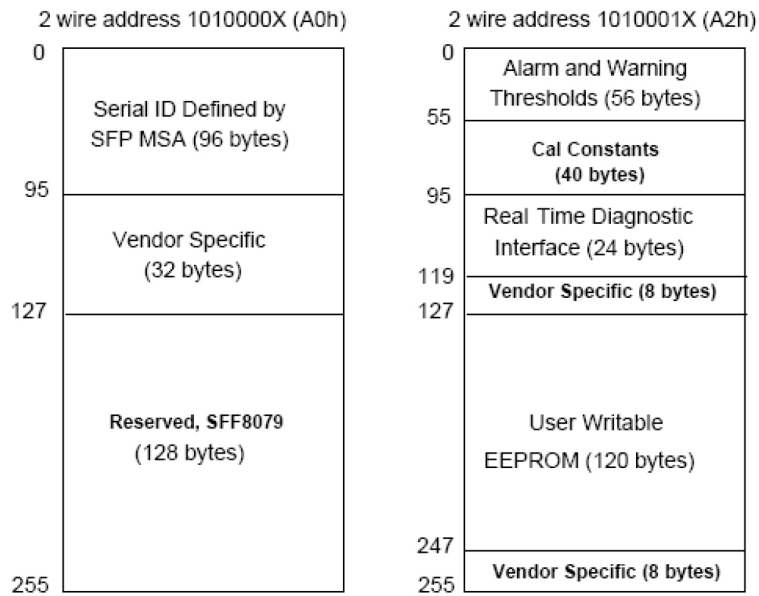

About AddOn Networks

In 1999, AddOn Networks entered the market with a single product. Our founders fulfilled a severe shortage for compatible, cost-effective optical transceivers that compete at the same performance levels as leading OEM manufacturers. Adhering to the idea of redefining service and product quality not previously had in the fiber optic networking industry, AddOn invested resources in solution design, production, fulfillment, and global support.

Combining one of the most extensive and stringent testing processes in the industry, an exceptional free tech support center, and a consistent roll-out of innovative technologies, AddOn has continually set industry standards of quality and reliability throughout its history.

Reliability is the cornerstone of any optical fiber network and is engrained in AddOn's DNA. It has played a key role in nurturing the long-term relationships developed over the years with customers. AddOn remains committed to exceeding industry standards with certifications from ranging from NEBS Level 3 to ISO 9001:2005 with every new development while maintaining the signature reliability of its products.

U.S. Headquarters

Email: sales@addonnetworks.com

Telephone: +1 877.292.1701

Fax: 949.266.9273

Europe Headquarters

Email: salesupportemea@addonnetworks.com

Telephone: +44 1285 842070