

## FTCE4517E1PCM-AO

Finisar® FTCE4517E1PCM Compatible TAA 800GBase-DR8 PAM4 OSFP Transceiver (SMF, 1310nm, 500m, MPO-16, DOM, CMIS 5.0)

### Features

- Compliant with OSFP MSA Specifications
- Compliant with IEEE 802.3ck-2022: 8x100GAUI-1 C2M Electrical Interface
- Compliant with IEEE 802.3cu-2021: 8x100GBASE-DR Optical Interface
- MPO-16 Connector
- Operating Temperature: 0 to 70 Celsius
- Compliant with CMIS 5.0
- RoHS Compliant and Lead-Free
- Class 1 Laser



### Applications

- 800GBase Ethernet

### Product Description

This Finisar® FTCE4517E1PCM compatible OSFP transceiver provides 800GBase-DR8 throughput up to 500m over single-mode fiber (SMF) PAM4 using a wavelength of 1310nm via a MPO-16 connector. It can operate at temperatures between 0 and 70C. It has been programmed, uniquely serialized, and tested for data-traffic and application to ensure that it will initialize and perform identically. All of our transceivers comply with Multi-Source Agreement (MSA) standards to provide seamless network integration. Additional product features include Digital Optical Monitoring (DOM) support which allows access to real-time operating parameters. This transceiver is Trade Agreements Act (TAA) compliant. We stand behind the quality of our products and proudly offer a limited lifetime warranty.

AddOn's transceivers are RoHS compliant and lead-free.

TAA refers to the Trade Agreements Act (19 U.S.C. & 2501-2581), which is intended to foster fair and open international trade. TAA requires that the U.S. Government may acquire only "U.S.-made or designated country end products."



## Absolute Maximum Ratings

Parameter	Symbol	Min.	Typ.	Max.	Unit	Notes
Storage Temperature	Tstg	-40		85	°C	
Operating Case Temperature	Tc	0		70	°C	
Power Supply Voltage	Vcc	-0.5		3.6	V	
Relative Humidity (Non-Condensing)	RH	5		95	%	
Data Input Voltage Differential	V <sub>DIP-V<sub>DIN</sub></sub>			1	V	
Control Input Voltage	V <sub>i</sub>	-0.3		Vcc+0.5	V	
Control Output Current	I <sub>o</sub>	-20		20	mA	
Signaling Speed Per Lane	DRL		53.125		GBd	
Operating Distance		2		500	m	
Data Rate	DR		850		Gbps	

## Electrical Characteristics

Parameter	Symbol	Min.	Typ.	Max.	Unit	Notes
Power Supply Voltage	Vcc	3.135	3.3	3.465	V	
Instantaneous Peak Current at Hot Plug	I <sub>CC_IP</sub>			6600	mA	
Sustained Peak Current at Hot Plug	I <sub>CC_SP</sub>			5494.5	mA	
Maximum Power Dissipation	PD			16.5	W	
Maximum Power Dissipation (Low-Power Mode)	PD <sub>LP</sub>			2	W	
Control Input Voltage - High	V <sub>IH</sub>	Vcc*0.7		Vcc+0.3	V	
Control Input Voltage - Low	V <sub>IL</sub>	-0.3		Vcc*0.3	V	
2-Wire Serial Interface Clock Rate				400	kHz	
Power Supply Noise (1kHz to 1MHz, Pk-Pk)				66	mVp-p	
<b>Transmitter (TP1)</b>						
Differential Pk-Pk Input Voltage Tolerance		750			mV	
Pk-Pk AC Common-Mode Voltage Tolerance	Low-Frequency (V <sub>CM<sub>LF</sub></sub> )	32			mV	
	Full-Band (V <sub>CM<sub>FB</sub></sub> )	80			mV	
Differential-Mode to Common-Mode Return Loss	RLCd		802.3ck 120G-2		dB	
Effective Return Loss	ERL	8.5			dB	
Differential Termination Mismatch				10	%	
Single-Ended Voltage Tolerance Range		-0.4		3.3	V	
DC Common-Mode Voltage Tolerance		-0.35		2.85	V	
<b>Receiver (TP4)</b>						
Pk-Pk AC Common-Mode Voltage	Low-Frequency (V <sub>CM<sub>LF</sub></sub> )			32	mV	
	Full-Band (V <sub>CM<sub>FB</sub></sub> )			80	mV	
Differential Pk-Pk Output	Short-Mode			600	mV	

Voltage	Long-Mode				845	mV	
Eye Height		EH	15			mV	
Vertical Eye Closure		VEC			12	dB	
Common-Mode to Differential-Mode Return Loss		RLDc	802.3ck 120G-1			dB	
Effective Return Loss		ERL	8.5			dB	
Differential Termination Mismatch					10	%	
Transition Time			8.5			ps	
DC Common-Mode Voltage Tolerance			-0.35		2.85	V	

### Electrical Low-Speed Control and Sense Signal Specifications

Parameter	Symbol	Min.	Max.	Unit	Notes
Module Output SCL and SDA	VOL	0	0.4	V	
Module Input SCL and SDA	VIL	-0.3	Vcc*0.3	V	
	VIH	Vcc*0.7	Vcc+0.5	V	
INT/RSTn	Complaint with OSFP MSA 5.0				

## Optical Characteristics

Parameter	Symbol	Min.	Typ.	Max.	Unit	Notes
<b>Transmitter</b>						
Wavelength	$\lambda_C$	1304.5	1311	1317.5	nm	
Side-Mode Suppression Ratio	SMSR	30			dB	
Average Launch Power Per Lane	$AOP_L$	-2.9		4.0	dBm	1
Outer Optical Modulation Amplitude (OMA <sub>outer</sub> ) Per Lane	TOMA	-0.8		4.2	dBm	
Launch Power in OMA <sub>outer</sub> Minus TDECQ Per Lane	For ER $\geq$ 5dB	TOMA - TDECQ	-2.2		dBm	
	For ER < 5dB	TOMA - TDECQ	-1.9		dBm	
Transmitter and Dispersion Eye Closure for PAM4 (TDECQ) Per Lane	TDECQ			3.4	dB	
TDECQ – 10log10(Ceq) Per Lane	Ceq			3.4	dB	
Average Launch Power of Off Transmitter Per Lane	Toff			-15	dBm	
Extinction Ratio	ER	3.5			dB	
Transmitter Transition Time	Tr			17	ps	
RIN <sub>15.5OMA</sub>	RIN			-136	dB/Hz	
Optical Return Loss Tolerance	ORLT			15.5	dB	
Transmitter Reflectance	TR			-26	dB	2
<b>Receiver (TP4)</b>						
Wavelength	$\lambda_C$	1304.5	1311	1317.5	nm	
Damage Threshold Per Lane	$AOP_D$	5			dBm	
Average Receive Power Per Lane	$AOP_R$	-5.9		4	dBm	
Receive Power (OMA <sub>outer</sub> ) Per Lane	OMA <sub>R</sub>			4.2	dBm	
Receiver Reflectance	RR			-26	dB	
Receiver Sensitivity (OMA <sub>outer</sub> ) Per Lane	SOMA			Max. (-3.9, SECQ – 5.3)	dBm	3
Stressed Receiver Sensitivity (OMA <sub>outer</sub> ) Per Lane	SRS			-1.9	dBm	4
<b>Conditions of Stressed Receiver Sensitivity Test</b>						
Stressed Eye Closure for PAM4 (SECQ) Per Lane Under Test	SECQ		3.4		dB	
SECQ – 10log10 (Ceq) Per Lane Under Test	Ceq			3.4	dB	

### Notes:

1. Average launch power, per lane (minimum), is informative and not the principal indicator of signal strength.
2. Transmitter reflectance is defined looking into the transmitter.
3. Receiver sensitivity (OMA<sub>outer</sub>), per lane (maximum), is informative and is defined for a transmitter with a value of SECQ up to 3.4dB.
4. Measured with conformance test signal at TP3 for the BER =  $2.4 \times 10^{-4}$ .

## Pin Descriptions

Pin	Logic	Symbol	Name/Description	Notes
1		GND	Module Ground.	
2	CML-I	Tx2+	Transmitter Non-Inverted Data.	
3	CML-I	Tx2-	Transmitter Inverted Data.	
4		GND	Module Ground.	
5	CML-I	Tx4+	Transmitter Non-Inverted Data.	
6	CML-I	Tx4-	Transmitter Inverted Data.	
7		GND	Module Ground.	
8	CML-I	Tx6+	Transmitter Non-Inverted Data.	
9	CML-I	Tx6-	Transmitter Inverted Data.	
10		GND	Module Ground.	
11	CML-I	Tx8+	Transmitter Non-Inverted Data.	
12	CML-I	Tx8-	Transmitter Inverted Data.	
13		GND	Module Ground.	
14	LVC MOS-I/O	SCL	2-Wire Serial Interface Clock.	
15		Vcc	+3.3V Power Supply.	
16		Vcc	+3.3V Power Supply.	
17	Multi-Level	LPWn/PRSn	Low-Power Mode/Module Present.	
18		GND	Module Ground.	
19	CML-O	Rx7-	Receiver Inverted Data.	
20	CML-O	Rx7+	Receiver Non-Inverted Data.	
21		GND	Module Ground.	
22	CML-O	Rx5-	Receiver Inverted Data.	
23	CML-O	Rx5+	Receiver Non-Inverted Data.	
24		GND	Module Ground.	
25	CML-O	Rx3-	Receiver Inverted Data.	
26	CML-O	Rx3+	Receiver Non-Inverted Data.	
27		GND	Module Ground.	
28	CML-O	Rx1-	Receiver Inverted Data.	
29	CML-O	Rx1+	Receiver Non-Inverted Data.	
30		GND	Module Ground.	
31		GND	Module Ground.	
32	CML-O	Rx2+	Receiver Non-Inverted Data.	
33	CML-O	Rx2-	Receiver Inverted Data.	
34		GND	Module Ground.	
35	CML-O	Rx4+	Receiver Non-Inverted Data.	
36	CML-O	Rx4-	Receiver Inverted Data.	

37		GND	Module Ground.	
38	CML-O	Rx6+	Receiver Non-Inverted Data.	
39	CML-O	Rx6-	Receiver Inverted Data.	
40		GND	Module Ground.	
41	CML-O	Rx8+	Receiver Non-Inverted Data.	
42	CML-O	Rx8-	Receiver Inverted Data.	
43		GND	Module Ground.	
44	Multi-Level	INT/RSTn	Module Input/Module Reset.	
45		Vcc	+3.3V Power Supply.	
46		Vcc	+3.3V Power Supply.	
47	LVC MOS-I/O	SDA	2-Wire Serial Interface Data.	
48		GND	Module Ground.	
49	CML-I	Tx7-	Transmitter Inverted Data.	
50	CML-I	Tx7+	Transmitter Non-Inverted Data.	
51		GND	Module Ground.	
52	CML-I	Tx5-	Transmitter Inverted Data.	
53	CML-I	Tx5+	Transmitter Non-Inverted Data.	
54		GND	Module Ground.	
55	CML-I	Tx3-	Transmitter Inverted Data.	
56	CML-I	Tx3+	Transmitter Non-Inverted Data.	
57		GND	Module Ground.	
58	CML-I	Tx1-	Transmitter Inverted Data.	
59	CML-I	Tx1+	Transmitter Non-Inverted Data.	
60		GND	Module Ground.	

# Electrical Pad Layout

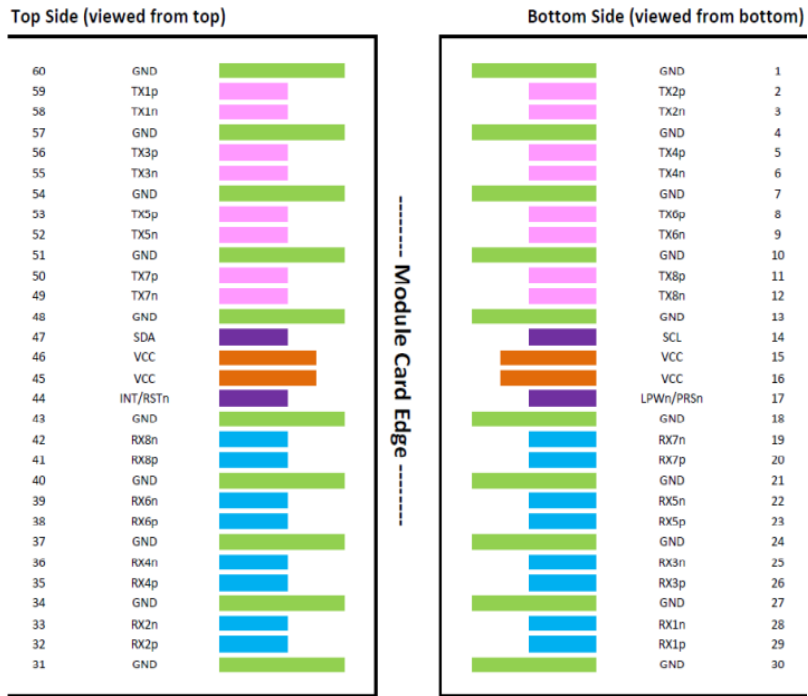

# Recommended OSFP Host Board Schematic

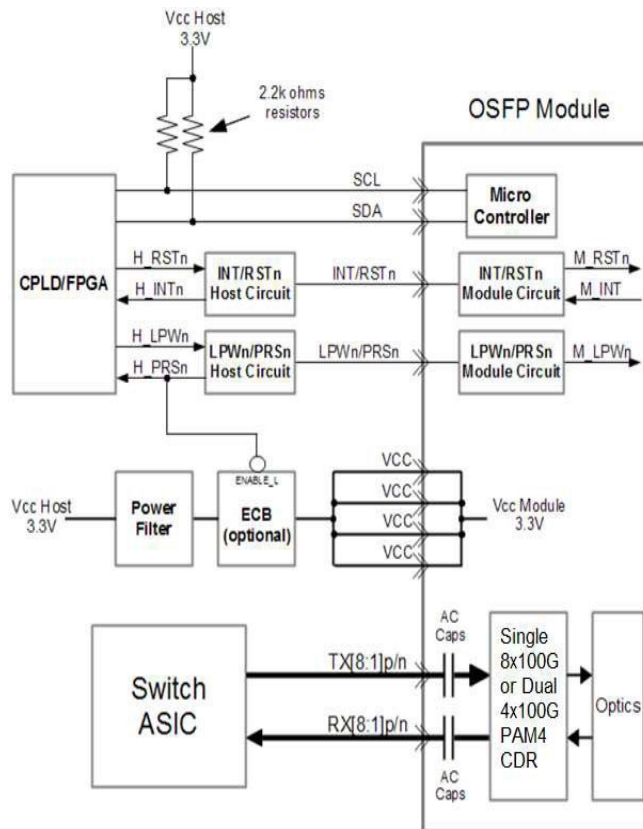

# Mechanical Specifications

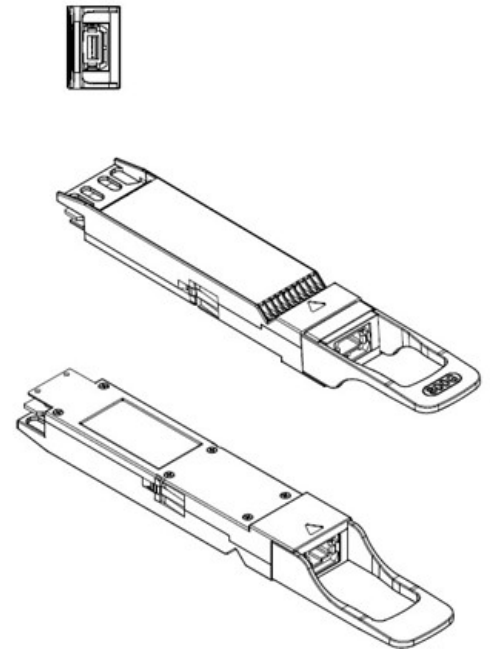
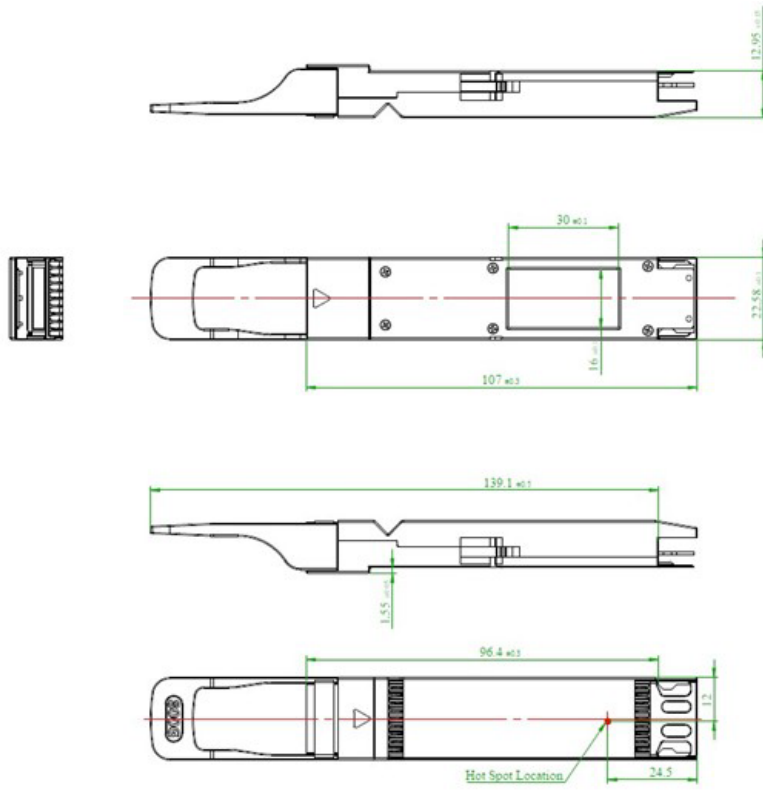

## About AddOn Networks

In 1999, AddOn Networks entered the market with a single product. Our founders fulfilled a severe shortage for compatible, cost-effective optical transceivers that compete at the same performance levels as leading OEM manufacturers. Adhering to the idea of redefining service and product quality not previously had in the fiber optic networking industry, AddOn invested resources in solution design, production, fulfillment, and global support.

Combining one of the most extensive and stringent testing processes in the industry, an exceptional free tech support center, and a consistent roll-out of innovative technologies, AddOn has continually set industry standards of quality and reliability throughout its history.

Reliability is the cornerstone of any optical fiber network and is ingrained in AddOn's DNA. It has played a key role in nurturing the long-term relationships developed over the years with customers. AddOn remains committed to exceeding industry standards with certifications ranging from NEBS Level 3 to ISO 9001:2015 with every new development while maintaining the signature reliability of its products.



## U.S. Headquarters

Email: [sales@addonnetworks.com](mailto:sales@addonnetworks.com)

Telephone: +1 877.292.1701

Fax: 949.266.9273

## Europe Headquarters

Email: [salesemea@addonnetworks.com](mailto:salesemea@addonnetworks.com)

Telephone: +44 1285 842070