

## FTLF1436W5BCV-AO

Finisar® FTLF1436W5BCV Compatible TAA 25GBase-LR SFP28 Transceiver Dual Rate 10/25G Capable (SMF, 1310nm,, 10km, LC, DOM, Rate-Selectable)

### Features

- SFF-8402 and SFF-8472 Compliance
- Duplex LC Connector
- Commercial Temperature 0 to 70 Celsius
- Single-mode Fiber
- Hot Pluggable
- Excellent ESD Protection
- Metal with Lower EMI



### Applications

- 25GBase Ethernet
- Access and Enterprise

### Product Description

This Finisar® FTLF1436W5BCV compatible SFP28 transceiver provides 25GBase-LR throughput up to 10km over single-mode fiber (SMF) using a wavelength of 1310nm via an LC connector. All of our transceivers are built to comply with Multi-Source Agreement (MSA) standards and are uniquely serialized and tested for data-traffic and application to ensure seamless network integration. Additional product features include Digital Optical Monitoring (DOM) support which allows access to real-time operating parameters. This transceiver is Trade Agreements Act (TAA) compliant. We stand behind the quality of our products and proudly offer a limited lifetime warranty.

AddOn's transceivers are RoHS compliant and lead-free.

TAA refers to the Trade Agreements Act (19 U.S.C. & 2501-2581), which is intended to foster fair and open international trade. TAA requires that the U.S. Government may acquire only "U.S.-made or designated country end products."



## Absolute Maximum Ratings

Parameter	Symbol	Min.	Typ.	Max.	Unit	Notes
Maximum Supply Voltage	V <sub>cc</sub>	-0.5		4.0	V	
Storage Temperature	T <sub>S</sub>	-40		85	°C	
Operating Case Temperature	T <sub>c</sub>	0	25	70	°C	
Relative Humidity	RH	5		95	%	
Data Rate			24.33 25.78		Gbps	
Bit Error Rate	BER			5x10 <sup>-5</sup>		1
Supported Link Length on 9/125um SMF, 25.78GB/s	L		10		km	2

### Notes:

1. Tested with PRBS 2<sup>31</sup>-1 test pattern for 25.78Gbps operation.
2. Distances are based on FC-PI-6 Rev 3.1 and IEEE 802.3 standards with FEC.

## Electrical Characteristics

Parameter	Symbol	Min.	Typ.	Max.	Unit	Notes	
Supply Voltage	V <sub>cc</sub>	3.135	3.3	3.465	V		
Module Supply Current	I <sub>cc</sub>			450	mA		
Power Dissipation	P <sub>D</sub>			1500	mW		
Data Rate	BR		25.78				
<b>Transmitter</b>							
Input Differential Impedance	Z <sub>IN</sub>		100		Ω		
Differential Data Input Swing	V <sub>in,pp</sub>	180		700	mVp-p		
TX Fault	Transmitter Fault	V <sub>OH</sub>	2.0		Host_Vcc	V	
	Normal Operation	V <sub>OL</sub>	0		0.8	V	
TX Disable	Transmitter Disable	V <sub>IH</sub>	2.0		Host_Vcc	V	T
	Transmitter Enable	V <sub>IL</sub>	0		0.8	V	
<b>Receiver</b>							
Output Differential Impedance	Z <sub>OUT</sub>		100		Ω		
Differential Data Output Swing	V <sub>OUT,pp</sub>	300		850	mVp-p	1	
Data Output Rise Time/Fall Time	T <sub>r</sub> /T <sub>f</sub>	15			ps	2	
RX_LOS	Loss of Signal (LOS)	V <sub>OH</sub>	2.0		Host_Vcc	V	3
	Normal Operation	V <sub>OL</sub>	0		0.8	V	3

**Notes:**

3. Internally AC coupled but requires an external 100Ω differential load termination.
4. 20-80%
5. LOS is an open collector output. Should be pulled up with 4.7KΩ on the host board.

**Optical Characteristics**

Parameter	Symbol	Min.	Typ.	Max.	Unit	Notes
<b>Transmitter</b>						
Launch Optical Power	P <sub>o</sub>	-5		+2	dBm	1
Extinction Ratio	ER	3.5			dB	
Center Wavelength Range	λ <sub>c</sub>	1295	1310	1325	nm	
Transmitter Dispersion Penalty	TDP			2.7	dB	
Spectral Width	Δλ			1	nm	2
Optical Rise/Fall Time @25.78GBps	T <sub>r</sub> /T <sub>f</sub>	15			ps	3
Optical Return Loss Tolerance	ORLT			12	dB	
Pout @TX_Disable Asserted	P <sub>off</sub>			-30	dBm	
<b>Receiver</b>						
Center Wavelength	λ <sub>c</sub>	1260	1310	1370	nm	
Receiver OMA Sensitivity	ROMA			-12	dBm	4
Receiver Overload (P <sub>avg</sub> )	P <sub>MAX</sub>	2			dBm	
Optical Return Loss	ORLT	26			dB	
LOS De-Assert	LOSD			-16	dBm	
LOS Assert	LOSA	-30			dBm	
LOS Hysteresis		0.5			dB	

**Notes:**

1. Class 1 Laser Safety per FDA/CDRH and EN (IEC) 60825 regulation.
2. 20dB spectral width.
3. Unfiltered, 20-80%.
4. Measured with PRBS 2<sup>31</sup>-1 at 5x10<sup>-5</sup> BER.

## Pin Descriptions

Pin	Symbol	Name/Descriptions	Ref.
1	VeeT	Transmitter Ground.	1
2	TX_Fault	Transmitter Fault. LVTTTL-O. "High" indicated a fault condition.	2
3	TX_Disable	Transmitter Disable. LVTTTL-I. "High" or "open" disables the transmitter.	3
4	SDA	2-Wire Serial Interface Data. LVCMOS-I/O. MOD-DEF2.	4
5	SCL	2-Wire serial interface Clock. LVCMOS-I/O. MOD-DEF1.	4
6	MOD_ABS	Module Absent (Output). Connected to VeeT or VeeR in the module.	5
7	RS0	NA.	6
8	RX_LOS	Receiver Loss of Signal. LVTTTL-O.	2
9	RS1	NA.	6
10	VeeR	Receiver Ground.	1
11	VeeR	Receiver Ground.	1
12	RD-	Inverse Received Data out. CML-O.	
13	RD+	Received Data out. CML-O.	
14	VeeR	Receiver Ground.	
15	VccR	+3.3V Receiver Power.	
16	VccT	+3.3V Transmitter Power.	
17	VeeT	Transmitter Ground.	1
18	TD+	Transmitter Data In. CML-I.	
19	TD-	Inverse Transmitter Data In. CML-I.	
20	VeeT	Transmitter Ground.	1

### Notes:

1. The module signal grounds are isolated from the module case.
2. This is an open collector/drain output that on the host board requires a 4.7KΩ to 10KΩ pull-up resistor to Host\_Vcc.
3. This input is internally biased high with a 4.7KΩ to 10KΩ pull-up resistor to VccT.
4. 2-Wire Serial Interface Clock and Data lines require an external pull-up resistor dependent on the capacitance load.
5. This is a ground return that on the host board requires a 4.7KΩ to 10KΩ pull-up resistor to Host\_Vcc.
6. Rate select can also be set through the 2-wire bus in accordance with SFF-8472 v. 12.1. Rx Rate Select is set at Bit 3, Byte 110, and Address A2h, and Tx Rate Select is set at Bit 3, Byte 118, Address A2h.

**Note:** Writing a "1" selects maximum bandwidth operation. Rate select is the logic OR of the input state of Rate Select Pin and 2-wire bus.

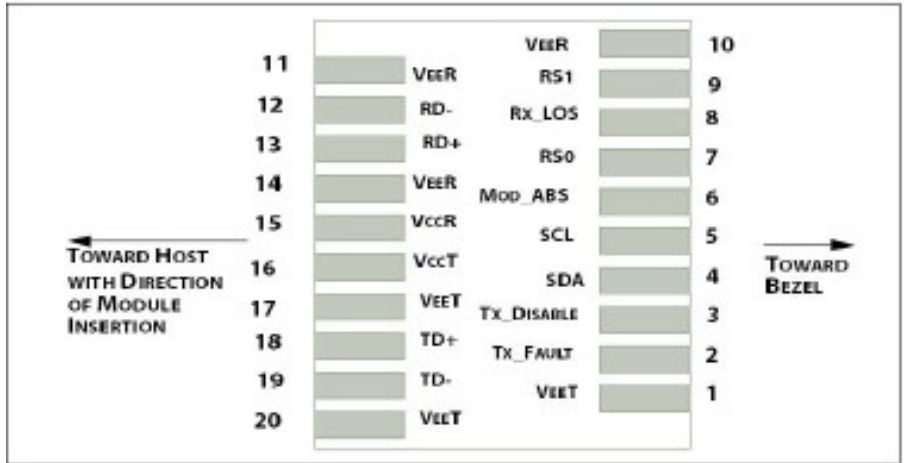

Host PCB SFP28 pad assignment

**Recommended Host Board**

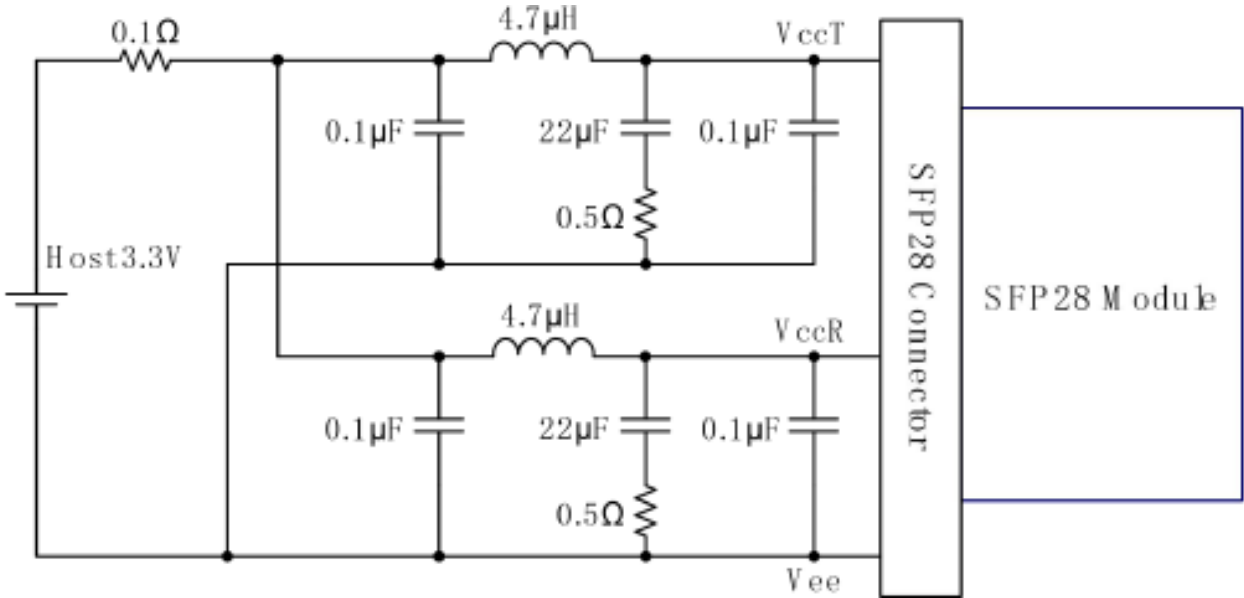

Recommended Host Board Power Supply Filter Network

## Recommended Application Interface Block Diagram

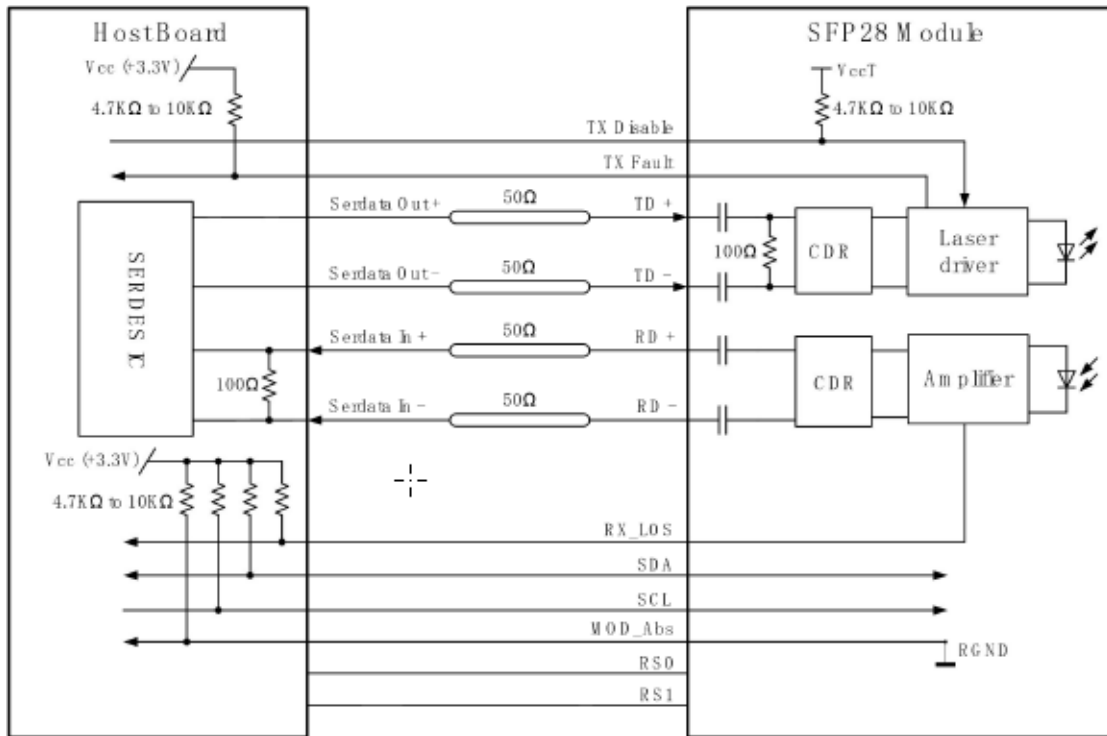

## Mechanical Specifications

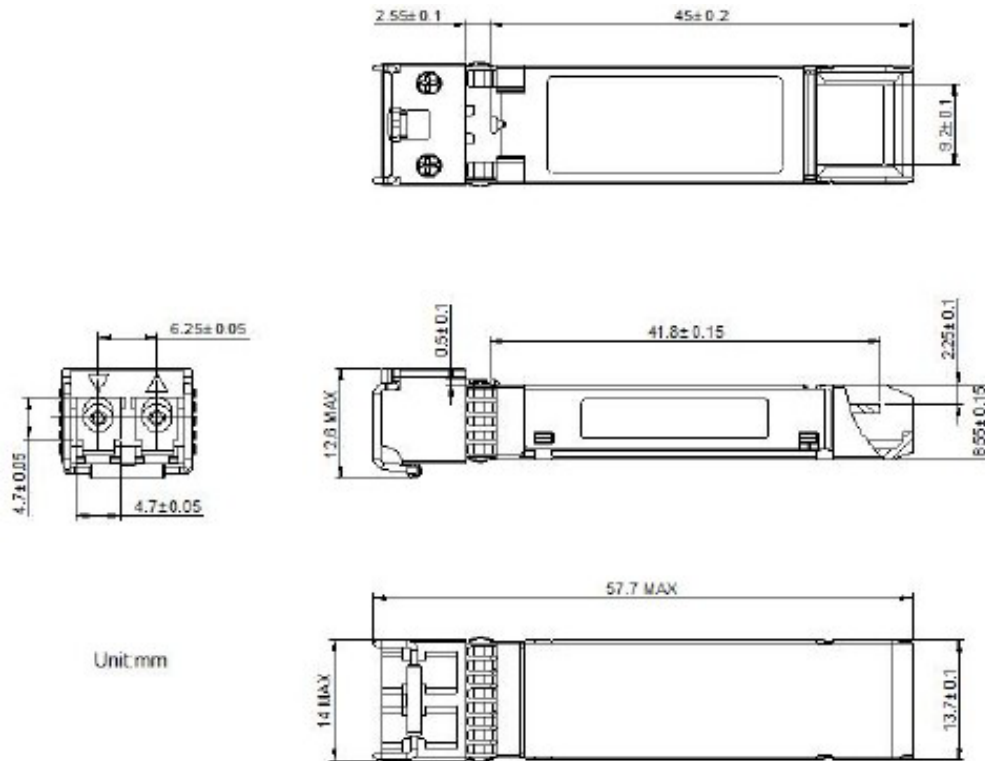

## About AddOn Networks

In 1999, AddOn Networks entered the market with a single product. Our founders fulfilled a severe shortage for compatible, cost-effective optical transceivers that compete at the same performance levels as leading OEM manufacturers. Adhering to the idea of redefining service and product quality not previously had in the fiber optic networking industry, AddOn invested resources in solution design, production, fulfillment, and global support.

Combining one of the most extensive and stringent testing processes in the industry, an exceptional free tech support center, and a consistent roll-out of innovative technologies, AddOn has continually set industry standards of quality and reliability throughout its history.

Reliability is the cornerstone of any optical fiber network and is ingrained in AddOn's DNA. It has played a key role in nurturing the long-term relationships developed over the years with customers. AddOn remains committed to exceeding industry standards with certifications ranging from NEBS Level 3 to ISO 9001:2015 with every new development while maintaining the signature reliability of its products.



## U.S. Headquarters

Email: [sales@addonnetworks.com](mailto:sales@addonnetworks.com)

Telephone: +1 877.292.1701

Fax: 949.266.9273

## Europe Headquarters

Email: [salesemea@addonnetworks.com](mailto:salesemea@addonnetworks.com)

Telephone: +44 1285 842070