

QSFP-40GB-ZR4-HW2-C

Huawei® Compatible TAA 40GBase-ZR4 QSFP+ Transceiver (SMF, 1295nm to 1309nm, 80km, LC, DOM)

Features:

- Compliant with QSFP28 MSA
- 4 cooled 10.3125Gbps channels LAN WDM EML TOSA
- 4 channels SOA PIN photo detector
- Single +3.3V power supply
- Class 1 laser safety certified
- Duplex LC Connector
- Single-mode Fiber
- Commercial Temperature 0 to 70 Celsius
- RoHS Compliant and Lead Free



Applications:

- 40GBase Ethernet

Product Description

This Huawei® compatible QSFP+ transceiver provides 40GBase-ZR4 throughput up to 80km over single-mode fiber (SMF) using a wavelength of 1295nm to 1309nm via an LC connector. It can operate at temperatures between 0 and 70C. Our transceiver is built to meet or exceed OEM specifications and is guaranteed to be 100% compatible with Huawei®. It has been programmed, uniquely serialized, and tested for data-traffic and application to ensure that it will initialize and perform identically. All of our transceivers comply with Multi-Source Agreement (MSA) standards to provide seamless network integration. Additional product features include Digital Optical Monitoring (DOM) support which allows access to real-time operating parameters. This transceiver is Trade Agreements Act (TAA) compliant. We stand behind the quality of our products and proudly offer a limited lifetime warranty.

ProLabs' transceivers are RoHS compliant and lead-free.

TAA refers to the Trade Agreements Act (19 U.S.C. & 2501-2581), which is intended to foster fair and open international trade. TAA requires that the U.S. Government may acquire only "U.S.-made or designated country end products."



Absolute Maximum Ratings

Parameter	Symbol	Min.	Typ.	Max.	Unit
Supply Voltage	V _{cc}	-0.5		4.0	V
Supply Voltage	V _{cc}	3.135	3.3	3.465	V
Storage Temperature	T _{stg}	-40		85	°C
Operating Case Temperature	T _c	0	25	70	°C
Relative Humidity	RH	5		95	%
Data Rate Per Channel		10.3125			Gbps

Notes:

1. Stresses exceeding the absolute maximum ratings can cause permanent damage to the device.
2. These are absolute stress ratings only.
3. Functional operation of the device is not implied at these or any other conditions in excess of those given in the operational sections of the datasheet.
4. Exposure to absolute maximum ratings for extended periods can adversely affect device reliability.

Electrical Characteristics

Parameter	Symbol	Min.	Typ.	Max.	Unit
Module Supply Current	I _{cc}			1650	mA
Power Dissipation	P _{DISS}			5000	mW
Transmitter					
Single-Ended Input Voltage Tolerance		-0.3		4.0	V
Input Differential Impedance	Z _{IN}		100		Ω
Differential Data Input Swing	V _{IN,pp}	190		700	mVp-p
AC Common-Mode Input Voltage Tolerance		15			mV
Differential Input Voltage Swing Threshold			50		mVp-p
Receiver					
Single-Ended Output Voltage		-0.3		4.0	V
Output Differential Impedance	Z _{OUT}	90	100	110	Ω
Differential Data Output Swing	V _{OUT,pp}	300		850	mVp-p
AC Common-Mode Output Voltage				7.5	mV

Optical Characteristics

Parameter	Symbol	Min.	Typ.	Max.	Unit	Notes
Transmitter						
Launch Optical Power Per Lane	Po	2.0		6.5	dBm	1
Total Launch Optical Power	Po			12.5	dBm	1
Center Wavelength Range	L1	1294.53	1295.56	1296.59	nm	
	L2	1299.02	1300.05	1301.09	nm	
	L3	1303.54	1304.58	1305.63	nm	
	L4	1308.09	1309.14	1310.19	nm	
Extinction Ratio	ER	8			dB	1
Spectral Width (-20dB)	$\Delta\lambda$			1	nm	
Side-Mode Suppression Ratio	SMSR	30			dB	
Optical Return Loss Tolerance	ORLT			20	dB	
POUT @ Tx_Disable Asserted	Poff			-30	dBm	1
Eye Mask (X1, X2, X3, Y1, Y2, Y3)	(0.25, 0.4, 0.45, 0.25, 0.28, 0.4)					
Receiver						
Center Wavelength	L1	1294.53	1295.56	1296.59	nm	
	L2	1299.02	1300.05	1301.09	nm	
	L3	1303.54	1304.58	1305.63	nm	
	L4	1308.09	1309.14	1310.19	nm	
Sensitivity Per Channel (OMA)	S1			-26.9	dBm	2
Sensitivity Per Channel (Average)	S2			-28	dBm	2
Overload (Per Channel)	POL	2			dBm	
Damage Threshold (Per Channel)	Pdmg	4.5			dBm	
Receiver Reflectance	Rf			-26	dB	
LOS De-Assert	LOSD			-28	dBm	
LOS Assert	LOSA	-35			dBm	
LOS Hysteresis	LOSH	0.5		5	dB	

Notes:

1. Measured with a PRBS $2^{31}-1$ test pattern @10.3125Gbps.
2. Measured with a PRBS $2^{31}-1$ test pattern, @10.3125Gbps, and BER $5.0E^{-5}$.

Pin Description

Pin	Symbol	Name/Description	Note
1	GND	Transmitter Ground (Common with Receiver Ground).	1
2	Tx2-	Transmitter Inverted Data Input.	
3	Tx2+	Transmitter Non-Inverted Data Output.	
4	GND	Transmitter Ground (Common with Receiver Ground).	1
5	Tx4-	Transmitter Inverted Data Input.	
6	Tx4+	Transmitter Non-Inverted Data Output.	
7	GND	Transmitter Ground (Common with Receiver Ground).	1
8	ModSelL	Module Select.	2
9	ResetL	Module Reset.	2
10	VccRx	+3.3V Power Supply Receiver.	
11	SCL	2-Wire Serial Interface Clock.	2
12	SDA	2-Wire Serial Interface Data.	2
13	GND	Transmitter Ground (Common with Receiver Ground).	1
14	Rx3+	Receiver Non-Inverted Data Output.	
15	Rx3-	Receiver Inverted Data Output.	
16	GND	Transmitter Ground (Common with Receiver Ground).	1
17	Rx1+	Receiver Non-Inverted Data Output.	
18	Rx1-	Receiver Inverted Data Output.	
19	GND	Transmitter Ground (Common with Receiver Ground).	1
20	GND	Transmitter Ground (Common with Receiver Ground).	1
21	Rx2-	Receiver Inverted Data Output.	
22	Rx2+	Receiver Non-Inverted Data Output.	
23	GND	Transmitter Ground (Common with Receiver Ground).	1
24	Rx4-	Receiver Inverted Data Output.	
25	Rx4+	Receiver Non-Inverted Data Output.	
26	GND	Transmitter Ground (Common with Receiver Ground).	1
27	ModPrsl	Module Present.	
28	IntL	Interrupt.	2
29	VccTx	+3.3V Transmitter Power Supply.	
30	Vcc1	+3.3V Power Supply.	
31	LPMODE	Low-Power Mode.	2
32	GND	Transmitter Ground (Common with Receiver Ground).	1
33	Tx3+	Transmitter Non-Inverted Data Input.	
34	Tx3-	Transmitter Inverted Data Output.	
35	GND	Transmitter Ground (Common with Receiver Ground).	1
36	Tx1+	Transmitter Non-Inverted Data Input.	
37	Tx1-	Transmitter Inverted Data Output.	
38	GND	Transmitter Ground (Common with Receiver Ground).	1

Notes:

1. The module signal grounds are isolated from the module case.
2. This is an open collector/drain output that on the host board requires a 4.7kΩ to 10kΩ pull-up resistor to Host_Vcc.

Host PCB QSFP28 Pad Assignment Top View

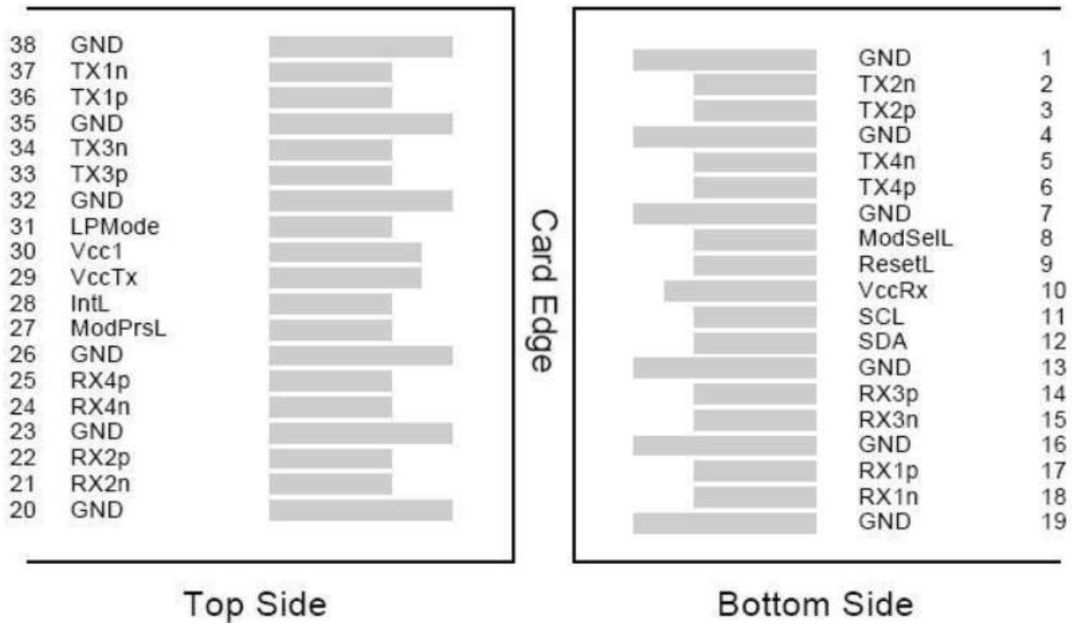

Recommended Host Board Power Supply Filter Network

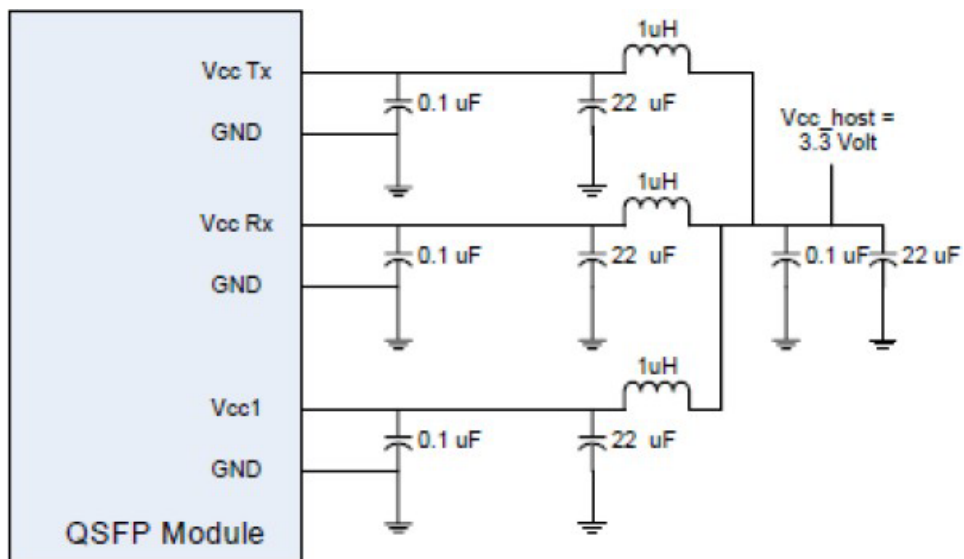

Recommended Application Interface Block Diagram

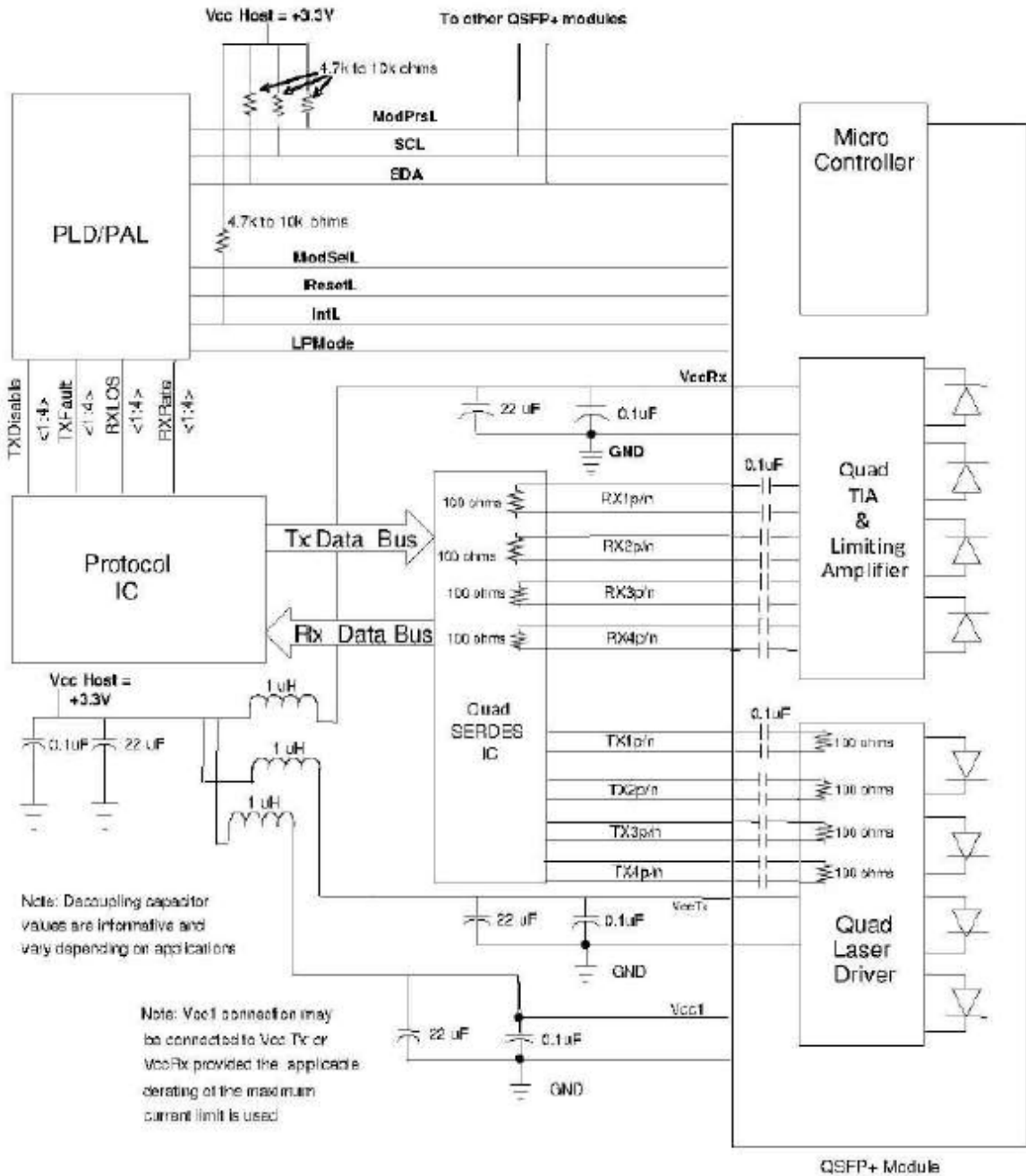

Mechanical Specifications

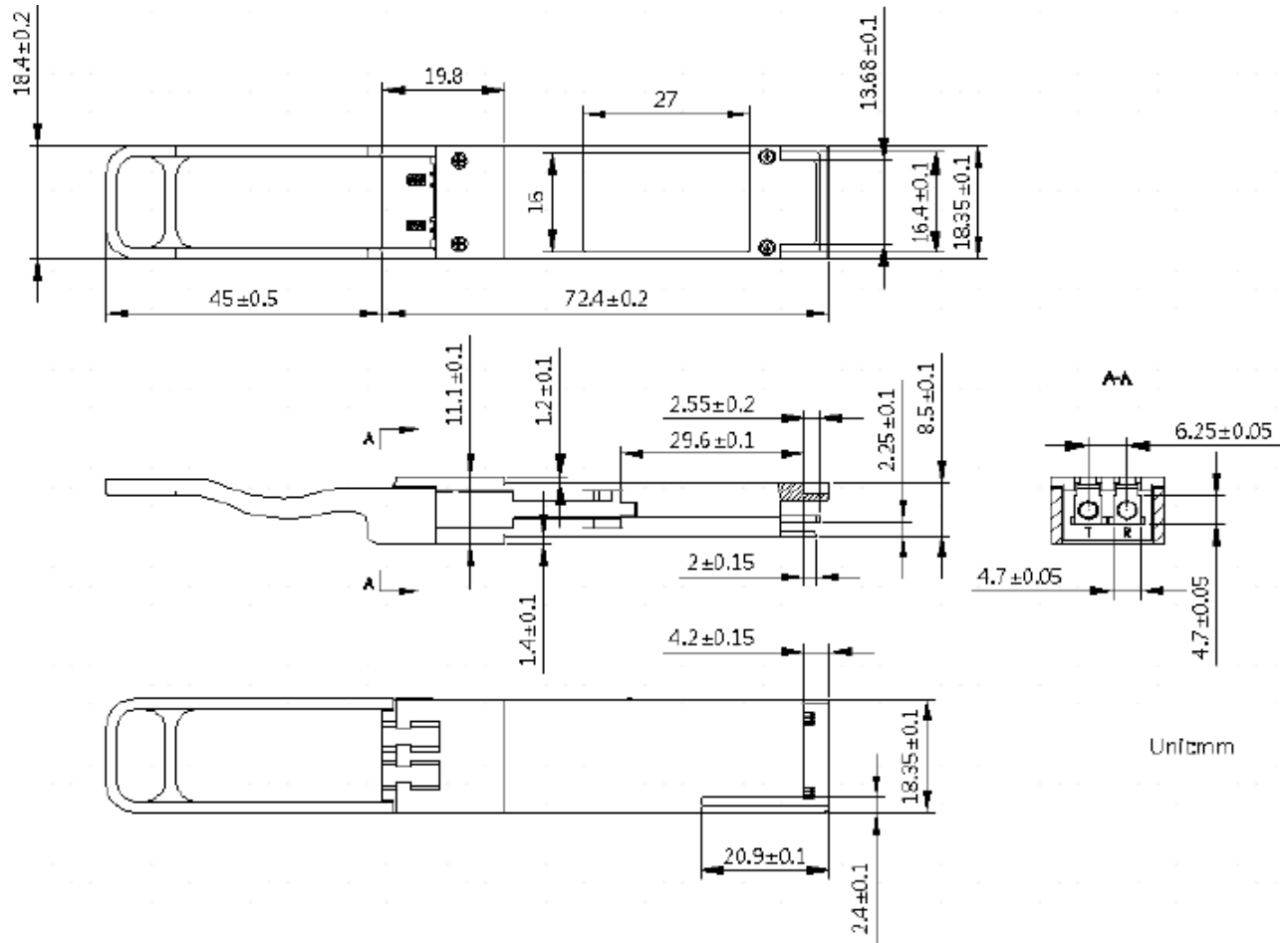

About ProLabs

Our extensive experience comes as standard. For over 20 years ProLabs has delivered optical connectivity solutions that give our customers freedom and choice through our ability to provide seamless interoperability. At the heart of our company is the ability to provide state-of-the-art optical transport and connectivity solutions that are compatible with more than 100 optical switching and transport platforms.

A Complete Portfolio of Network Solutions

ProLabs is focused on innovations in optical transport and connectivity. The combination of our knowledge of optics and networking equipment enables ProLabs to be your single source for optical transport and connectivity solutions from 100Mb to 1.6T while providing innovative solutions that increase network efficiency. We provide the optical connectivity expertise that is compatible with and enhances your switching and transport equipment.

The Trusted Partner

Customer service is our number one value. ProLabs has invested in people, labs and manufacturing capacity to ensure compatible products, and immediate answers to your questions. With Engineering and Manufacturing offices in the U.K. and U.S. augmented by field offices throughout the U.S., U.K. and Asia, ProLabs is able to be our customers best advocate 24 hours a day.



Contact Information

ProLabs US

Email: sales@prolabs.com

Telephone: 952-852-0252

ProLabs UK

Email: salessupport@prolabs.com

Telephone: +44 1285 719 600