

SFP-10GB-BXD54-100-HW2-C

Huawei® Compatible TAA 10GBase-BX SFP+ Transceiver (SMF, 1550nmTx/1490nmRx, 100km, LC, DOM)

Features:

- Power Consumption of 2W
- Supports 9.95 to 11.3Gbps Bit Rates
- Hot-Pluggable
- LC Connector
- Cooled EML Transmitter, APD Photo-Detector
- SMF Links up to 100km
- 3.3V Power Supply
- Operating Temperature: 0 to 70 Celsius
- RoHS Compliant and Lead-Free

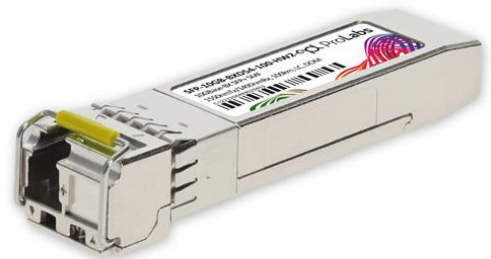

Applications:

- 10GBase Ethernet

Product Description

This Huawei® compatible SFP+ transceiver provides 10GBase-BX throughput up to 100km over single-mode fiber (SMF) using a wavelength of 1550nmTx/1490nmRx via an LC connector. This bidirectional unit must be used with another transceiver or network appliance of complimenting wavelengths. It is guaranteed to be 100% compatible with the equivalent Huawei® transceiver. This easy to install, hot swappable transceiver has been programmed, uniquely serialized and data-traffic and application tested to ensure that it will initialize and perform identically. Digital optical monitoring (DOM) support is also present to allow access to real-time operating parameters. This transceiver is Trade Agreements Act (TAA) compliant. We stand behind the quality of our products and proudly offer a limited lifetime warranty.

ProLabs' transceivers are RoHS compliant and lead-free.

TAA refers to the Trade Agreements Act (19 U.S.C. & 2501-2581), which is intended to foster fair and open international trade. TAA requires that the U.S. Government may acquire only "U.S.-made or designated country end products.")



Absolute Maximum Ratings

Parameter	Symbol	Min.	Typ.	Max.	Unit	Notes
Maximum Supply Voltage	Vcc	-0.5		4	V	
Storage Temperature	Tstg	-40		85	°C	
Operating Case Temperature	Tc	0		70	°C	
Relative Humidity	RH	0		85	%	

Electrical Characteristics

Parameter	Symbol	Min.	Typ.	Max.	Unit	Notes
Power Supply Voltage	Vcc	3.135	3.3	3.465	V	
Power Supply Current	Icc			600	mA	
Power Consumption	P			2	W	
Transmitter						
Input Differential Impedance	RIN		100		Ω	1
Tx Input Single-Ended DC Voltage Tolerance (VeeT)	V	-0.3		4	V	
Differential Data Input Swing	VIN,pp	180		700	mV	2
Transmit Disable Voltage	VD	2		Vcc	V	3
Transmit Enable Voltage	VEN	Vee		Vee+0.8	V	
Receiver						
Single-Ended Output Voltage Tolerance	V	-0.3		4	V	
Rx Output Differential Voltage	VOOUT,pp	300		850	mV	
Rx Output Rise and Fall Time	Tr/Tf	30			ps	4
LOS Fault	V _{LOS Fault}	2		Host_Vcc	V	5
LOS Normal	V _{LOS Normal}	Vee		Vee+0.5	V	5
Timing Characteristics						
Tx_Disable Assert Time	t_off			10	us	
Tx_Disable Negate Time	t_on			1	ms	
Time to Initialize Include Reset of Tx_Fault	t_int			300	ms	
Tx_Fault from Fault to Assertion	t_fault			100	us	
Tx_Disable Time to Start Reset	t_reset	10			us	
Receiver Loss of Signal Assert Time	T _{A,Rx_LOS}			100	us	
Receiver Loss of Signal De-Assert Time	T _{d,Rx_LOS}			100	us	
Rate Select Change Time	t_ratesel			10	us	
Serial ID Clock Time	t_serial-clock			100	kHz	

Notes:

1. Connected directly to the Tx data input pins. AC coupling from pins into laser driver IC.
2. Per SFF-8431 Rev. 3.0.
3. Into 100Ω differential termination.
4. 20-80%.
5. LOS is an open collector output. Should be pulled up with 4.7k to 10kΩ on the host board. Normal operation is “logic 0.” Loss of signal is “logic 1.” Maximum pull-up voltage is 5.5V.

Optical Characteristics

Parameter	Symbol	Min.	Typ.	Max.	Unit	Notes
Transmitter						
Center Wavelength	λ_C		1550		nm	
Spectral Width	$\Delta\lambda$			0.3	nm	
Average Optical Power	P_{avg}	1		5	nm	1
Optical Power OMA	POMA	-1.2			dBm	
Laser Off Power	Poff			-30	dBm	
Extinction Ratio	ER	8.2			dB	
Transmitter Dispersion Penalty	TDP			3.0	dB	2
Relative Intensity Noise	RIN			-128	dB/Hz	3
Optical Return Loss Tolerance		21			dB	
Receiver						
Optical Center Wavelength	λ_C		1490		nm	
Receiver Sensitivity	Rx_sen			-26	dBm	4
Receiver Reflectance	Rrx			-26	dB	
Receiver Overload	Sat	-7			dBm	5
LOS Assert	LOSA	-37			dBm	
LOS De-Assert	LOSD			-27	dBm	
LOS Hysteresis	LOSH	0.5			dB	

Notes:

1. Average power figures are informative only, per IEEE802.3ae.
2. TWDP figure requires the host board to be SFF-8431 compliant. TWDP is calculated using the Matlab code provided in Clause 68.6.6.2 of IEEE802.3ae.
3. 12dB reflection.
4. Conditions of stressed receiver tests per IEEE802.3ae. CSRS testing requires the host board to be SFF-8431 compliant.
5. Receiver overload specified in OMA and under the worst comprehensive stressed conditions.

Pin Descriptions

Pin	Symbol	Name/Description	Notes
1	VeeT	Module Ground.	1
2	Tx_Fault	Module Transmitter Fault.	2
3	Tx_Disable	Transmitter Disable. Turns off transmitter laser output.	3
4	SDL	2-Wire Serial Interface Data.	
5	SCL	2-Wire Serial Interface Clock.	
6	MOD_ABS	Module Absent. Connect to VeeR or VeeT in the module.	2
7	RS0	Rate Select 0. Optionally controls the SFP+ receiver. When "high," input data rate is >4.5Gbps. When "low," input data rate is <=4.5Gbps.	
8	LOS	Receiver Loss of Signal Indication.	4
9	RS1	Rate Select 0. Optionally controls the SFP+ transmitter. When "high," input data rate is >4.5Gbps. When "low," input data rate is <=4.5Gbps.	
10	VeeR	Module Ground.	1
11	VeeR	Module Ground.	1
12	RD-	Receiver Inverted Data Output.	
13	RD+	Receiver Non-Inverted Data Output.	
14	VeeR	Module Ground.	1
15	VccR	3.3V Receiver Power Supply.	
16	VccT	3.3V Transmitter Power Supply.	
17	VeeT	Module Ground.	1
18	TD+	Transmitter Inverted Data Output.	
19	TD-	Transmitter Non-Inverted Data Output.	
20	VeeT	Module Ground.	1

Notes:

1. The module ground pins shall be isolated from the module case.
2. This pin is an open collector/drain output pin and shall be pulled up with 4.7kΩ to 10kΩ to the Host_Vcc on the host board.
3. This pin shall be pulled up with 4.7kΩ to 10kΩ to the VccT in the module.
4. This pin is an open collector/drain output pin and shall be pulled up with 4.7kΩ to 10kΩ to the Host_Vcc on the host board.

Pin Assignments

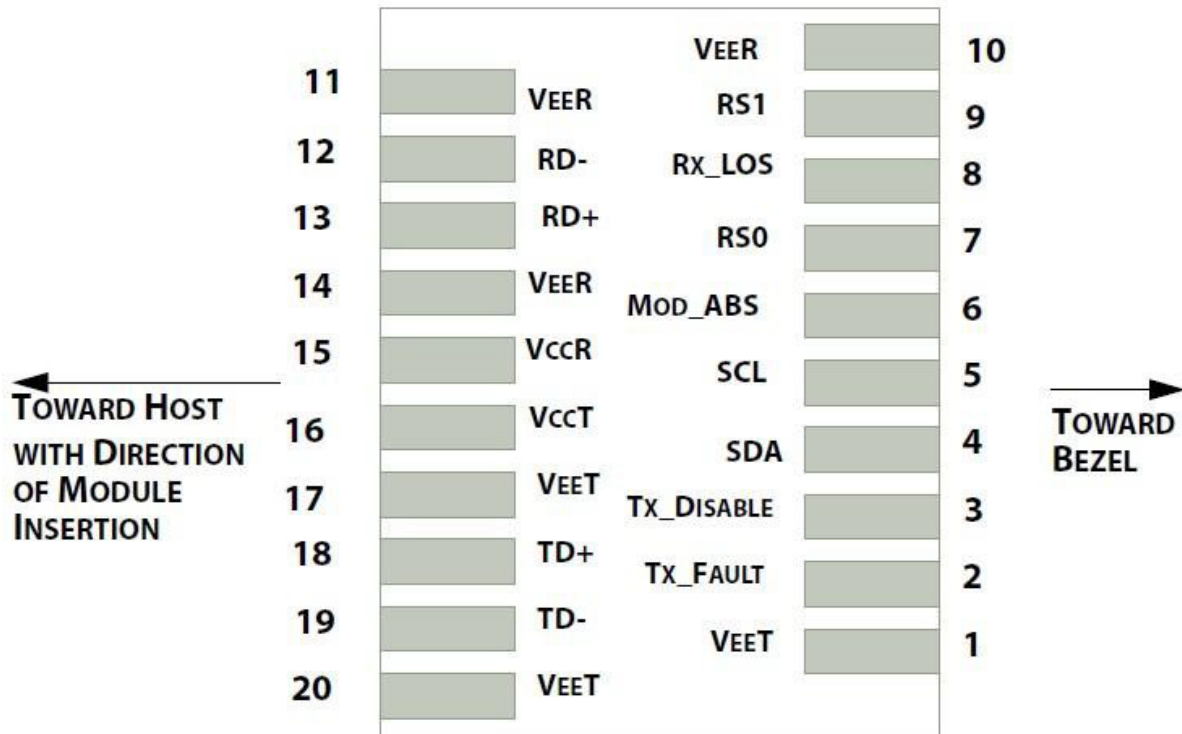

Recommended Circuit

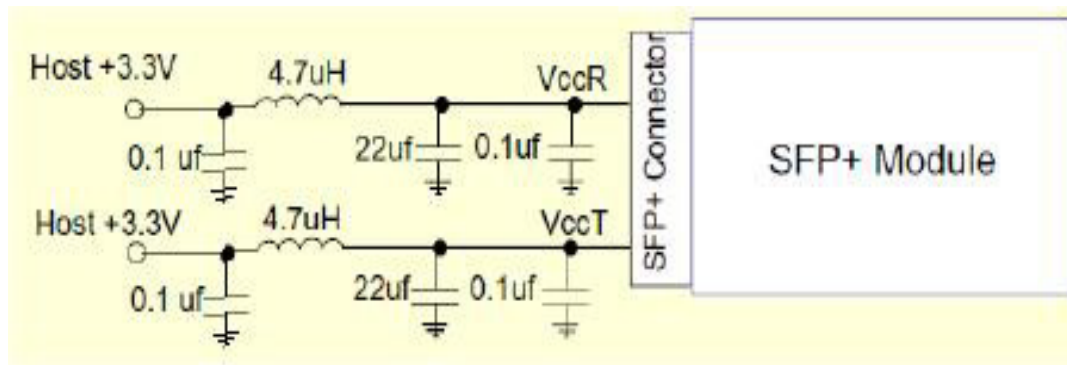

Recommended Host Board Power Supply Circuit

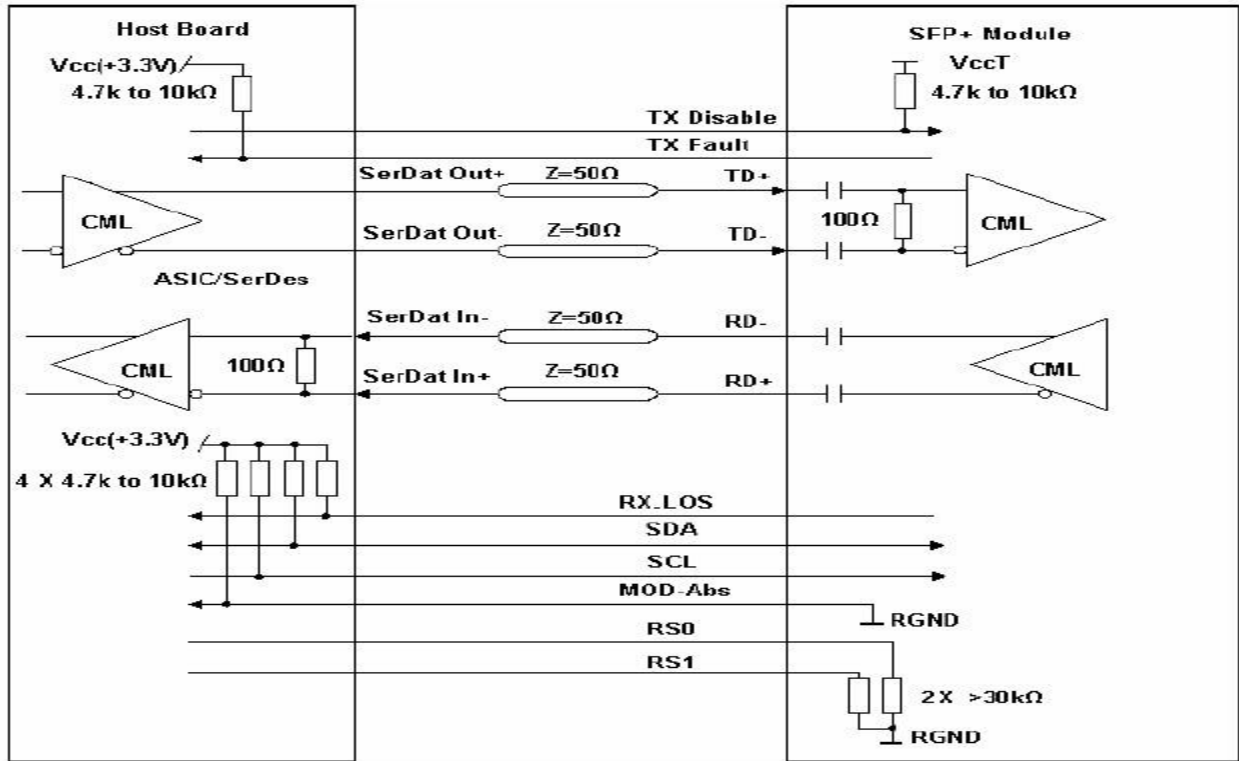

Mechanical Specifications

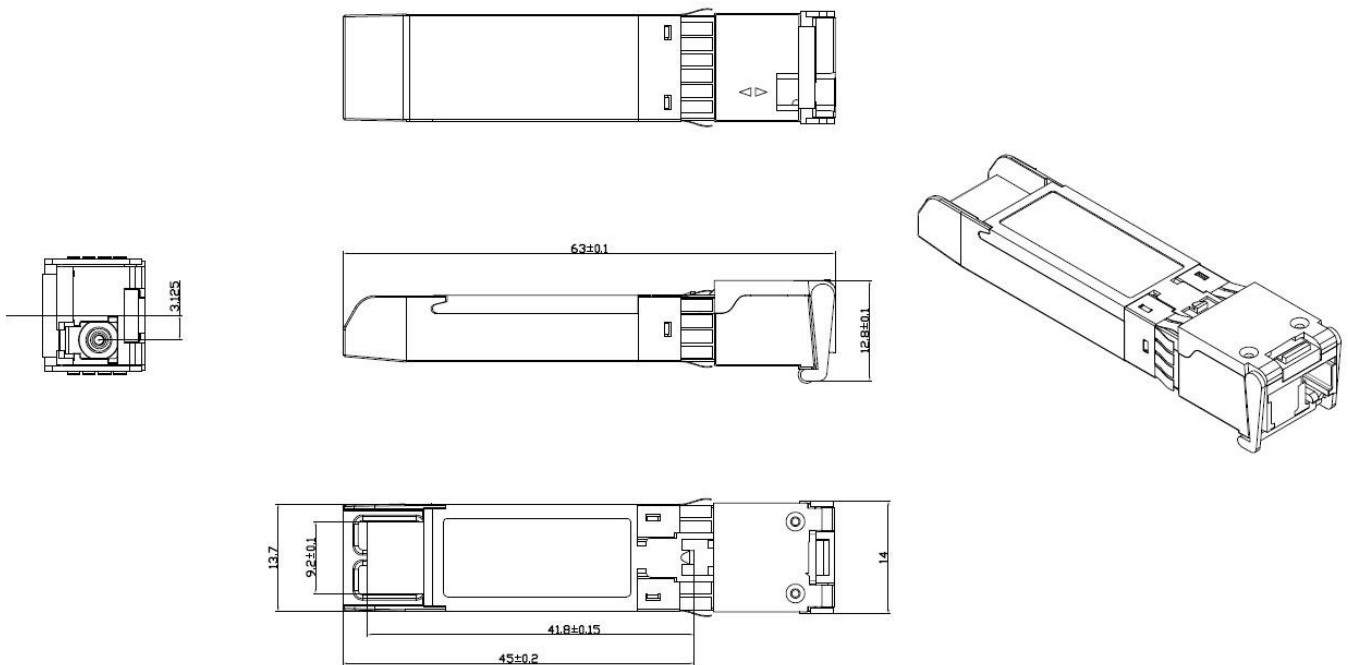

About ProLabs

Our extensive experience comes as standard. For over 20 years ProLabs has delivered optical connectivity solutions that give our customers freedom and choice through our ability to provide seamless interoperability. At the heart of our company is the ability to provide state-of-the-art optical transport and connectivity solutions that are compatible with more than 100 optical switching and transport platforms.

A Complete Portfolio of Network Solutions

ProLabs is focused on innovations in optical transport and connectivity. The combination of our knowledge of optics and networking equipment enables ProLabs to be your single source for optical transport and connectivity solutions from 100Mb to 1.6T while providing innovative solutions that increase network efficiency. We provide the optical connectivity expertise that is compatible with and enhances your switching and transport equipment.

The Trusted Partner

Customer service is our number one value. ProLabs has invested in people, labs and manufacturing capacity to ensure compatible products, and immediate answers to your questions. With Engineering and Manufacturing offices in the U.K. and U.S. augmented by field offices throughout the U.S., U.K. and Asia, ProLabs is able to be our customers best advocate 24 hours a day.



Contact Information

ProLabs US

Email: sales@prolabs.com

Telephone: 952-852-0252

ProLabs UK

Email: salessupport@prolabs.com

Telephone: +44 1285 719 600