

02312EVX-C

Huawei® 02312EVX Compatible TAA 50GBase-BX PAM4 QSFP28 Transceiver (SMF, 1295nmTx/1309nmRx, 40km, LC, DOM)

Features:

- Compliant with QSFP28 Standard and 50GBASE-ER: SFF-8665 Revision 1.9, SFF-8636 Revision 2.9
- Compliant with IEEE802.3 50GAUI-2 C2M electrical interface
- Bi-directional application
- Single 3.3V Supply Voltage
- Maximum power consumption 4.5W
- EML laser and APD Receiver
- QSFP28 MSA package with single LC connector
- Two Wire Serial Interface with Digital Diagnostic Monitoring
- Complies with EU Directive 2011/65/EU (RoHS compliant)
- Operating Temperature: 0C to 70C

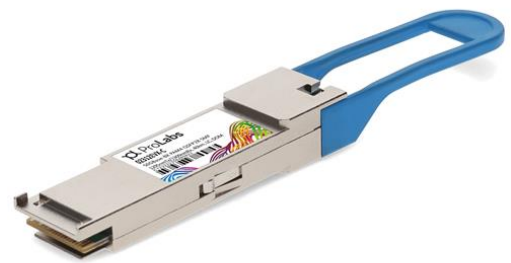

Applications:

- 50GBase Ethernet
- Access and Enterprise

Product Description

This Huawei® 02312EVX compatible QSFP28 transceiver provides 50GBase-BX PAM4 throughput up to 40km over single-mode fiber (SMF) using a wavelength of 1295nmTx/1309nmRx via an LC connector. It is guaranteed to be 100% compatible with the equivalent Huawei® transceiver. This easy to install, hot swappable transceiver has been programmed, uniquely serialized and data-traffic and application tested to ensure that it will initialize and perform identically. Digital optical monitoring (DOM) support is also present to allow access to real-time operating parameters. This transceiver is Trade Agreements Act (TAA) compliant. We stand behind the quality of our products and proudly offer a limited lifetime warranty.

ProLabs' transceivers are RoHS compliant and lead-free.

TAA refers to the Trade Agreements Act (19 U.S.C. & 2501-2581), which is intended to foster fair and open international trade. TAA requires that the U.S. Government may acquire only "U.S.-made or designated country end products."



Absolute Maximum Ratings

Parameter	Symbol	Min.	Typ.	Max.	Unit
Maximum Supply Voltage	Vcc	-0.5		3.6	V
Storage Temperature	TS	-40		+85	°C
Operating Case Temperature	TC	0		70	°C
Relative Humidity (non-condensing)	RH	5		85	%
Data Rate	DRL		26.5625		GBaud/s
			26.5625x2		Gbit/s
Operating Distance		2		40000	m

Electrical Characteristics

High-Speed Signal: Compliant to 50GAUI-2 C2M (IEEE 802.3cd)

Low-Speed Signal: Compliant to SFF-8679

Parameter	Symbol	Min.	Typ.	Max.	Unit	Notes
Supply Voltage	VCC	3.135	3.3	3.465	V	
Steady state current	Isupply			1298.7	mA	
Instantaneous peak current at hot plug	ICC_IP			1800	mA	Per pin
Sustained peak current at hot plug	ICC_SP			1485	mA	Per pin
Maximum Power Dissipation	PD			4.5	W	
Maximum Power Dissipation, Low Power Mode	PDLP			1.5	W	
Two Wire Serial Interface Clock Rate				400	kHz	
Power Noise and Ripple noise tolerance 10 Hz to 10 MHz (peak-to-peak)				66	mVpp	
Rx Differential Data Output Load			100		ohms	
Transmitter (Module Input)						
Differential Data Input Amplitude	VIN,P-P			900	mVpp	1
Differential Termination Mismatch				10	%	
LPMode, Reset and ModSelL	VIL	-0.3		0.8	V	
	VIH	2		VCC+0.3	V	
Receiver (Module Output)						
Differential Data Output Amplitude	VOUT,P-P			900	mVpp	1
Differential Termination Mismatch				10	%	
Output Rise/Fall Time, 20%~80%	TR	12			ps	
ModPrsL and Intl	VOL	0		0.4	V	IOL=4mA
	VOH	VCC-0.5		VCC+0.3	V	IOL=-4mA

Notes:

1. Amplitude customization beyond these specs is dependent on validation in customer system.

Optical Characteristics

Parameter	Symbol	Min.	Typ.	Max.	Unit	Notes
Transmitter						
Wavelength	λ	1294.53	1295	1296.59	nm	
Side-mode suppression ratio	SMSR	30			dB	
Average launch power	P_{OUT}	0.4		6.63	dBm	
Average launch power of OFF transmitter	P_{OUT_OFF}			-15	dBm	
Outer Optical Modulation Amplitude (OMAouter)	P_{OUTL}	3.4		7.4	dBm	
Extinction ratio	ER	6			dB	
Launch power in OMAouter minus TDECQ	OMA-TDECQ	2			dBm	
Transmitter and dispersion eye closure for PAM4 (TDECQ)	TDECQ			3.2	dB	1
Transmitter reflectance				-26	dB	
Receiver						
Wavelength	λ	1308.09	1309	1310.19	nm	
Receiver sensitivity (OMAouter)				Max (-15.1, SECC - 16.5)	dBm	2
Damage Threshold	P_{damage}	-2.37			dBm	
Overload		-3.37			dBm	
Average Receive Power		-17.6		-3.37	dBm	
Receive power (OMAouter)	OMA			-2.6	dBm	
Receiver Reflectance	RXR			-26	dB	
LOS assert	LOSA	-30			dBm	
LOS de-assert	LOSD			-20	dBm	
LOS hysteresis	LOSH	0.5			dB	

Notes:

1. Measured with a PRBS215-1 test pattern @53.125Gbps.
2. Measured with a PRBS231-1 test pattern @53.125Gbps, $BER \leq 2.4E-4$. IEEE 802.3cd clause 139 equation 139-2.

Control and Status Timing Requirement

Item	Symbol	Min.	Max.	Unit	Notes
Initialization time	t_init		10	s	1
Reset Init Assert Time	t_reset_init	10		us	
Serial Bus Hardware Ready Time	t_serial		2	s	
Monitor Data Ready Time	t_data		2	s	
Reset Assert Time	t_reset		10	s	1
LPMMode Assert Time	ton_LPMMode		100	ms	
LPMMode De-assert Time	toff_LPMMode		10	s	1
IntL Assert Time	ton_IntL		200	ms	
IntL Deassert Time	toff_IntL		500	us	
Rx LOS Assert Time	ton_los		100	ms	
Flag Assert Time	ton_flag		200	ms	
Mask Assert Time	ton_mask		100	ms	
Mask Deassert Time	toff_mask		100	ms	
Power_over-ride or Power-set Assert Time	ton_Pdown		100	ms	
Power_over-ride or Power-set Deassert Time	toff_Pdown		10	s	1

Notes:

1. Timing not compliant with SFF-8679 V1.8.

Squelch and Disable Timing

Item	Symbol	Min.	Max.	Unit	Notes
Rx Squelch Assert Time	ton_Rxsq		15	ms	
Rx Squelch Deassert Time	toff_Rxsq		350	ms	1
Tx Squelch Assert Time	ton_Txsq		400	ms	
Tx Squelch Deassert Time	toff_Txsq		400	ms	
Tx Disable Assert Time	ton_txdis		100	ms	
TX_Disable Deassert Time	toff_txdis		400	ms	
Rx Output Disable Assert Time	ton_rxdis		100	ms	
Rx Output Disable Deassert Time	toff_rxdis		350	ms	1
Squelch Disable Assert Time	ton_sqdis		100	ms	
Squelch Disable Deassert Time	toff_sqdis		100	ms	

Notes:

1. Timing not compliant with SFF-8679 V1.8.

Pin Descriptions

Pin	Logic	Symbol	Descriptions	Plug Sequence	Notes
1		GND	Ground	1	1
2	CML-I	Tx2n	Transmitter Inverted Data Input	3	
3	CML-I	Tx2p	Transmitter Non-Inverted Data Input	3	
4		GND	Ground	1	1
5	CML-I	Tx4n	Transmitter Inverted Data Input	3	3
6	CML-I	Tx4p	Transmitter Non-Inverted Data Input	3	3
7		GND	Ground	1	1
8	LVTTTL-I	ModselL	Module Select	3	
9	LVTTTL-I	ResetL	Module Reset	3	
10		Vcc Rx	+3.3V Power Supply Receiver	2	2
11	LVCNOS-I/O	SCL	2-wire serial interface clock	3	
12	LVCNOS-I/O	SDA	2-wire serial interface data	3	
13		GND	Ground	1	1
14	CML-O	Rx3p	Receiver Non-Inverted Data Output	3	3
15	CML-O	Rx3n	Receiver Inverted Data Output	3	3
16		GND	Ground	1	1
17	CML-O	Rx1p	Receiver Non-Inverted Data Output	3	
18	CML-O	Rx1n	Receiver Inverted Data Output	3	
19		GND	Ground	1	1
20		GND	Ground	1	1
21	CML-O	Rx2n	Receiver Inverted Data Output	3	
22	CML-O	Rx2p	Receiver Non-Inverted Data Output	3	
23		GND	Ground	1	1
24	CML-O	Rx4n	Receiver Inverted Data Output	3	3
25	CML-O	Rx4p	Receiver Non-Inverted Data Output	3	3
26		GND	Ground	1	1
27	LVTTTL-O	ModPrsL	Module Present	3	
28	LVTTTL-O	IntL/Rx LOS	Interrupt/Rx LOS	3	4
29		Vcc Tx	+3.3V Power supply transmitter	2	2
30		Vcc1	+3.3V Power supply	2	2
31	LVTTTL-I	LPMode/TxDis	Low Power Mode/Tx disable	3	4
32		GND	Ground	1	1
33	CML-I	Tx3p	Transmitter Non-Inverted Data Input	3	3
34	CML-I	Tx3n	Transmitter Inverted Data Input	3	3
35		GND	Ground	1	1
36	CML-I	Tx1p	Transmitter Non-Inverted Data Input	3	
37	CML-I	Tx1n	Transmitter Inverted Data Input	3	
38		GND	Ground	1	1

Notes:

1. GND is the symbol for signal and supply (power) common for the QSFP+ module. All are common within the QSFP+ module and all module voltages are referenced to this potential unless otherwise noted. Connect these directly to the host board signal-common ground plane.
2. Vcc Rx, Vcc1 and Vcc Tx are the receiver and transmitter power supplies and shall be applied concurrently.
3. Not used.
4. Dual function pin as specified into SFF-8679.

Electrical Pin-out Details

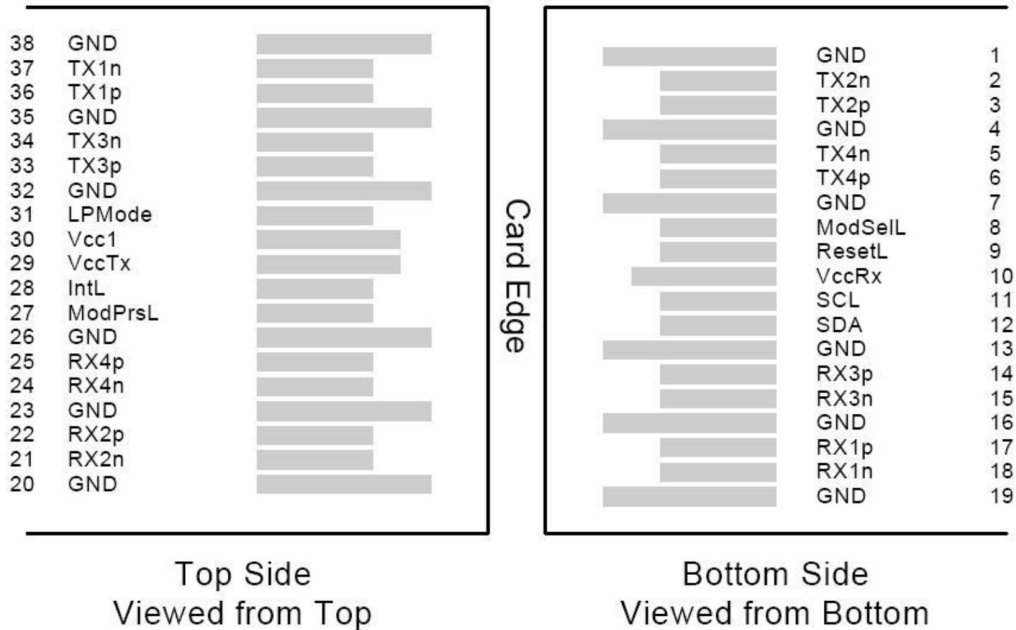

Recommended Host Board Power Supply Filter Network

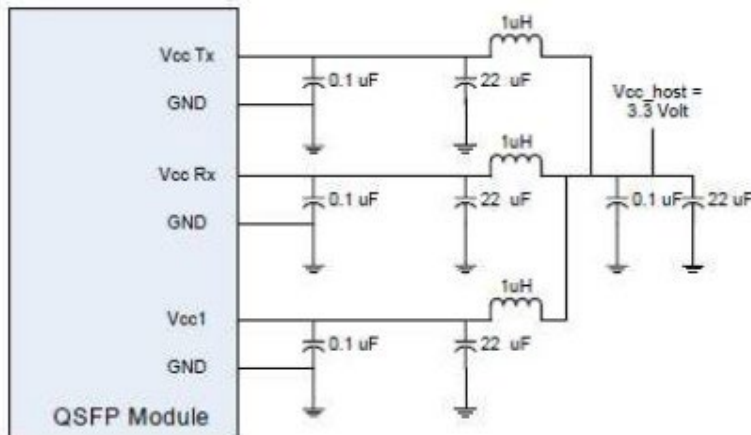

About ProLabs

Our extensive experience comes as standard. For over 20 years ProLabs has delivered optical connectivity solutions that give our customers freedom and choice through our ability to provide seamless interoperability. At the heart of our company is the ability to provide state-of-the-art optical transport and connectivity solutions that are compatible with more than 100 optical switching and transport platforms.

A Complete Portfolio of Network Solutions

ProLabs is focused on innovations in optical transport and connectivity. The combination of our knowledge of optics and networking equipment enables ProLabs to be your single source for optical transport and connectivity solutions from 100Mb to 1.6T while providing innovative solutions that increase network efficiency. We provide the optical connectivity expertise that is compatible with and enhances your switching and transport equipment.

The Trusted Partner

Customer service is our number one value. ProLabs has invested in people, labs and manufacturing capacity to ensure compatible products, and immediate answers to your questions. With Engineering and Manufacturing offices in the U.K. and U.S. augmented by field offices throughout the U.S., U.K. and Asia, ProLabs is able to be our customers best advocate 24 hours a day.



Contact Information

ProLabs US

Email: sales@prolabs.com

Telephone: 952-852-0252

ProLabs UK

Email: salessupport@prolabs.com

Telephone: +44 1285 719 600