

SFP-25GB-DW-C-A1-15-I-AR-OPC

Arista Networks® Compatible TAA 25GBase-DWDM SFP28 Transceiver C-Band 100GHz (SMF, Auto-Tunable, 15km, LC, DOM, -40 to 85C)

Features

- Retimed Data Rate 24.33-25.78Gbps
- Un-Retimed Data Rates Greater Than 1.2Gbps are Supported
- SFF-8432 and SFF-8472 Compliance
- Duplex LC Connector
- ITU-T C-Band 100GHz Spacing
- SmartTune MSA is Supported for Self-Tuning
- Industrial Temperature: -40 to 85 Celsius
- Single-Mode Fiber
- Hot Pluggable
- Excellent ESD Protection
- RoHS Compliant and Lead-Free



Applications:

- 25x Gigabit Ethernet over DWDM
- Access, Metro and Enterprise

Product Description

This Arista Networks® compatible SFP28 transceiver provides 25GBase-DWDM throughput up to 15km over single-mode fiber (SMF) using an auto-tunable wavelength via an LC connector. It is capable of withstanding rugged environments and can operate at temperatures between -40 and 85C. Our transceiver is built to meet or exceed OEM specifications and is guaranteed to be 100% compatible with Arista Networks®. It has been programmed, uniquely serialized, and tested for data-traffic and application to ensure that it will initialize and perform identically. All of our transceivers comply with Multi-Source Agreement (MSA) standards to provide seamless network integration. Additional product features include Digital Optical Monitoring (DOM) support which allows access to real-time operating parameters. This transceiver is Trade Agreements Act (TAA) compliant. We stand behind the quality of our products and proudly offer a limited lifetime warranty.

OptioConnect's transceivers are RoHS compliant and lead-free.

DWDM Wavelength ITU Channels - 100GHz Spacing

ITU Channel	Center Wavelength (nm)	Frequency (THz)	ITU Channel	Center Wavelength (nm)	Frequency (THz)
14	1566.31	191.4	38	1546.92	193.8
15	1565.50	191.5	39	1546.12	193.9
16	1564.68	191.6	40	1545.32	194.0
17	1563.86	191.7	41	1544.53	194.1
18	1563.05	191.8	42	1543.73	194.2
19	1562.23	191.9	43	1542.94	194.3
20	1561.42	192.0	44	1542.14	194.4
21	1560.61	192.1	45	1541.35	194.5
22	1559.79	192.2	46	1540.56	194.6
23	1558.98	192.3	47	1539.77	194.7
24	1558.17	192.4	48	1538.98	194.8
25	1557.36	192.5	49	1538.19	194.9
26	1556.55	192.6	50	1537.4	195.0
27	1555.75	192.7	51	1536.61	195.1
28	1554.94	192.8	52	1535.82	195.2
29	1554.13	192.9	53	1535.04	195.3
30	1553.33	193.0	54	1534.25	195.4
31	1552.52	193.1	55	1533.47	195.5
32	1551.72	193.2	56	1532.68	195.6
33	1550.92	193.3	57	1531.9	195.7
34	1550.12	193.4	58	1531.12	195.8
35	1549.32	193.5	59	1530.33	195.9
36	1548.51	193.6	60	1529.55	196.0
37	1547.72	193.7	61	1528.77	196.1

Absolute Maximum Ratings

Parameter	Symbol	Min.	Typ.	Max.	Unit	Notes
Maximum Supply Voltage	V _{CC} T	0		+3.6	V	+3.3V
Maximum Supply Voltage	V _{CC} R	0		+3.6	V	+3.3V
Optical Receiver Input	P _{IMAX}			+5	dBm	Average
Storage Temperature	T _{stg}	-40		+85	°C	
Operating Case Temperature	T _c	-40		+85	°C	1
ESD SFI Pins	ESD1			1	KV	HBM
ESD Except for SFI Pins	ESD2			2	KV	HBM

Notes:

- Case temperature reference point is shown below:

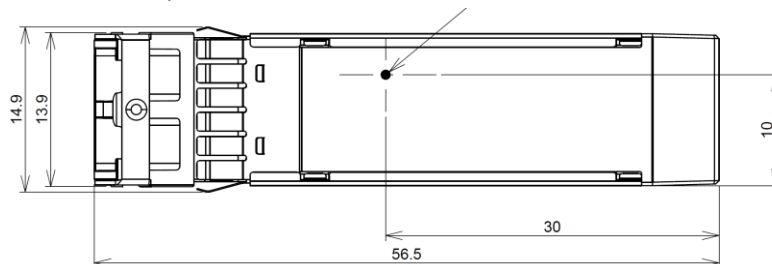

Electrical Characteristics

Parameter	Symbol	Min.	Typ.	Max.	Unit	Notes
Supply Voltage	Vcc	3.135	3.3	3.465	V	+3.3V
Power Consumption				2.5	W	
Inrush Current						
Icc Instantaneous Peak Current				600	mA	1, 2
Icc Sustained Peak Current				500	mA	1, 2
Transceiver						
Signaling Rate Per Lane (Range)		25.78125 ± 100ppm			GBd	
AC Common-Mode Output Voltage	RMS			17.5	mV	
Differential Output Voltage				900	mV	
Eye Width	EW8	0.57			UI	
Eye Height (Differential)	EH8	228			mV	
Vertical Eye Closure	VEC8			5	dB	
Differential Output Return Loss		Equation (83E-2)			dB	
Common- to Differential-Mode Conversion Return		Equation (83E-3)			dB	
Differential Termination Mismatch				10	%	
Transition Time (20-80%)		12			ps	
DC Common-Mode Voltage		-350		2850	mV	3
Receiver						
Signaling Rate Per Lane (Range)	TP1	25.78125 ± 100ppm			GBd	
Differential Pk-Pk Input Voltage Tolerance	TP1a	900			mV	
Differential Input Return Loss	TP1	Equation (83E-5)			dB	
Differential to Common-Mode Input Return Loss	TP1	Equation (83E-6)			dB	
Differential Termination Mismatch	TP1			10	%	
Module Stressed Input Test	TP1a	See 109B.3.4.2				
Single-Ended Voltage Tolerance Range	TP1a	-0.4 to 3.3			V	
DC Common-Mode Voltage	TP1	-350		2850	mV	3

Notes:

1. The maximum currents are the allowed currents for each power supply VccT or VccR, therefore the total module peak currents can be twice this value. The Instantaneous Peak Current is allowed to exceed the specified maximum current capacity of the connector contact for a short period.
2. Not to exceed the sustained peak limit for more than 50µs - may exceed this limit for shorter durations.
3. DC Common-Mode Voltage is generated by the host. Specification includes the effects of ground offset voltage.

4. Meets BER specified in 109B.3.4.2.

Optical Characteristics

Parameter	Symbol	Min.	Typ.	Max.	Unit	Notes
Transmitter						
Chromatic Dispersion		0		270	ps/nm	
Operating Distance 25G		10		15	km	1
Data Rate Retimed		24.33		25.78	Gbps	NRZ
Data Rate Un-Retimed		1.2		11.3	Gbps	
Wavelength		1528.773		1566.314	nm	2
Center Wavelength Spacing		100			GHz	
Frequency Range		191.40		196.1	THz	
Maximum Shift of Center Wavelength				ITU \pm 100	ppm	EOL
Optical Transmit Power	Po	0		4	dBm	EOL
Shuttered Output Power				-35	dBm	
Optical Power Stability	Δ Po	-1		1	dB	All Channels, BOL
Side-Mode Suppression	SMSR	35			dB	\pm 2.5nm, Modulated
Spectral Width	$\Delta\lambda$		0.3	0.5	nm	-20dB, Modulated
Extinction Ratio	ER	7.5			dB	Filtered, 25Gbps
Eye Mask		ITU-T G.959.1 NRZ 25G Ratio				3
Mask Margin		10			%	
Tuning Speed				150	ms	4
Receiver						
Data Rate Retimed		24.33		25.78	Gbps	NRZ
Data Rate Un-Retimed		1.2		11.3	Gbps	
Input Operating Wavelength		1260		1620	nm	5
Minimum Receiver Sensitivity 25G Back-to-Back	Prmin:B2B	-20			dBm	6
Maximum Input Power (Overload) 25G	Pro	-7			dBm	
Receiver Reflectance	RL			-35	dB	
LOS Assert				-27	dBm	
LOS De-Assert				-24	dBm	
LOS Hysteresis		0.5		5.0	dB	
LOS Assert Time				100	us	
LOS De-Assert Time				100	us	

Notes:

1. Maximum pre-FEC bit-error ratio = 5×10^{-5} .
2. 100GHz grid, 48 channels.
3. See G.959.1, Figure 7-4.
4. Warmed-up, from any Ch to any other Ch.
5. Specs guaranteed between 1529.55nm to 1560.61nm.
6. 25.78Gbps, $5E^{-5}$, OSNR>35dB.
7. The module electrical characteristics shall conform to the 25GAUI C2M (chip-to-module 25 Gigabit Attachment Unit Interface) in Annex 109B of IEEE Std 802.3, also with reference to Annex 83E the CAUI-4 C2M interface.

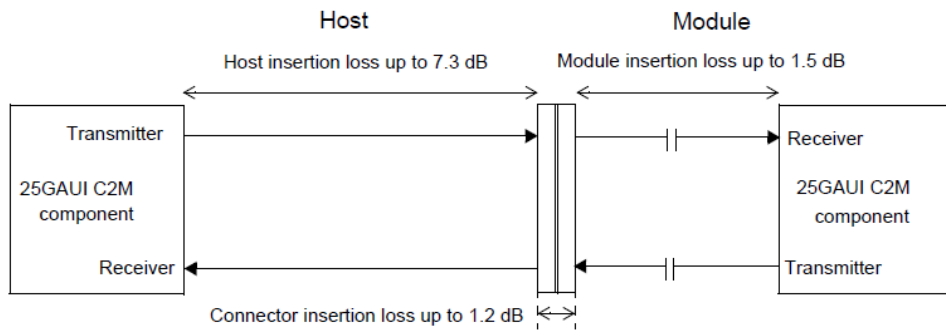

25GAUI C2M Insertion Loss Budget at 12.89GHz (IEEE 802.3, Figure 109B-2)

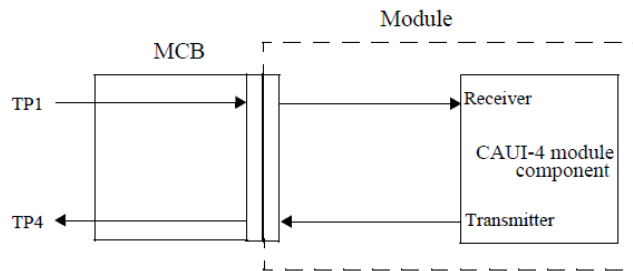

Module 25GAUI Test Points

Auto Tuning

The autotuning process is a host-independent scheme 100% compliant with the SmartTune MSA. The transceiver is automatically tuned to the port wavelength of an attached DWDM mux/demux.

TSFP+ Detail Function Setting

Parameter	Specifications
Rx Interface	APD, Limiting I/F
CDR	Tx: Not Supported Rx: Not Supported
Rx Decision Threshold (RDT)	Adjustable
Ch Frequency Coverage	191.40 to 196.10THz
Default Ch at Shipping	Ch 1 (191.40THz)
Ch After Start-Up	Persisting Last Saved Ch

Notes:

1. Tx_Fault is masked during wavelength tuning including at cold/warm start-up.
2. Wavelength switch is feasible when Tx_Disable is applied.

SFP+ 2-Wire Interface Timing Requirements

Parameter	Symbol	Min.	Max.	Unit	Conditions
Clock Frequency	fSCL	100	400	kHz	
Clock Pulse Width - Low	tLOW	1.3		μs	
Clock Pulse Width - High	tHIGH	0.6		μs	
Time Bus Free Before New Transaction Can Start	tBUF	20		μs	Between STOP and START
START Hold Time	tHD,STA	0.6		μs	
START Set-Up Time	tSU,STA	0.6		μs	
Data In Hold Time	tHD,DAT	0		μs	
Data In Set-Up Time	tSU,DAT	0.1		μs	
Input Rise Time (100kHz)	tR,100		1000	ns	1
Input Rise Time (400kHz)	tR,400		300	ns	1
Input Fall Time (100kHz)	tF,100		300	ns	1
Input Fall Time (400kHz) STOP Set-Up Time	tF,400		300	ns	1
	tSU,STO	0.6		μs	
Serial Interface Clock Holdoff "Clock Stretching"	T_clock_hold		500	μs	2
Complete Single or Sequential Write	tWR		40	ms	3
Endurance (Write Cycles)		10k		Cycles	4

Notes:

1. From (VIL, MAX – 0.15) to (VIH, MIN + 0.15).
2. Maximum time the SFP+ may hold the SCL line low before continuing R or W operation.

3. Complete (up to) 8-Byte write.
4. At maximum operating temperature.

SFP+ Timing Diagram

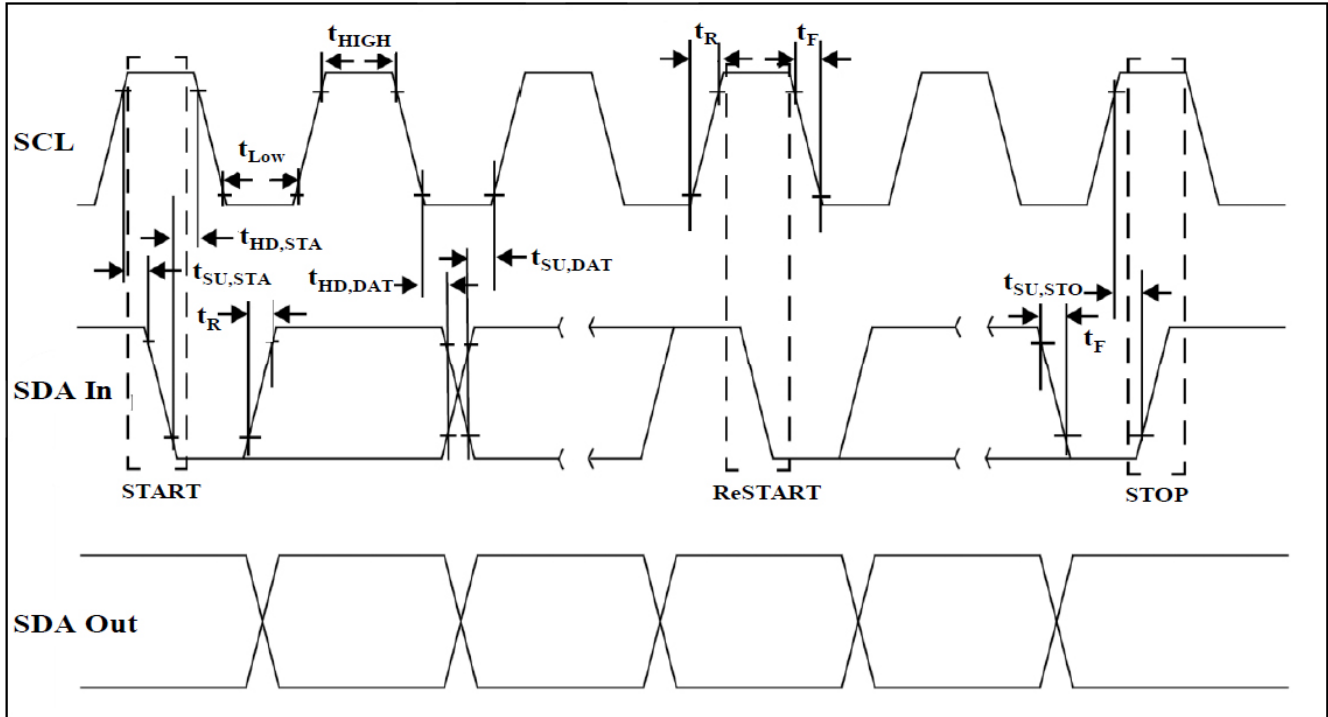

SFP+ Timing Requirements

Parameter	Symbol	Min.	Max.	Unit	Conditions
Tx_Disable Assert Time	T_off		100	μs	1
Tx_Disable Negate Time	T_on		2	ms	2
Time to Initialize 2-Wire Interface	T_2w_start_up		300	ms	3
Time to Initialize Cooled Module and Time to Power-Up a Cooled Module to Power Level II	T_start_up_cooled		90	sec	4
Tx_Fault Assert for a Cooled Module	Tx_fault_on_cooled		1	ms	5
Tx_Fault_Reset	T_reset	10		μs	6
Rx_LOS Assert Delay	T_los_on		100	μs	7
Rx_LOS Negate Delay	T_los_off		100	μs	8

Notes:

1. Rising edge of Tx_Disable to fall of output signal below 10% of nominal.
2. Falling edge of Tx_Disable to rise of output signal above 90% of nominal. This only applies in normal

operation, not during start-up or fault recovery.

3. From power on or hot plug after the supply meeting.
4. From power supplies meeting or hot plug, or Tx_Disable negated during power-up or Tx_Fault recovery, until cooled Power Level II part during fault recovery is fully operational. Also, from stop bit low-to-high SDA transition enabling Power Level II until the cooled module is fully operational.
5. From occurrence of fault to assertion of Tx_Fault.
6. Time Tx_disable must be held high to reset Tx_Fault.
7. From occurrence of loss of signal to assertion of Rx_LOS.
8. From occurrence of presence of signal to negation of Rx_LOS.

Pin Descriptions

Pin	Symbol	Name/Description	Notes
1	VeeT	Module Transmitter Ground.	1
2	Tx_Fault	Module Transmitter Fault.	2
3	Tx_Disable	Transmitter Disable. Turn off laser output.	3
4	SDA	2-Wire Serial Interface Data.	4
5	SCL	2-Wire Serial Interface Clock.	4
6	MOD_ABS	Module Absent. Connected to the VeeT or VeeR in the module.	5
7	RS0	N/A. 30kΩ pull-down inside the module.	
8	Rx_LOS	Receiver Loss of Signal Indicator.	2
9	RS1	N/A. 30kΩ pull-down inside the module.	
10	VeeR	Module Receiver Ground.	1
11	VeeR	Module Receiver Ground.	1
12	RD-	Receiver Inverted Data Output (SFI).	
13	RD+	Receiver Non-Inverted Data Output (SFI).	
14	VeeR	Module Receiver Ground.	1
15	VccR	+3.3V Receiver Power Supply.	6
16	VccT	+3.3V Transmitter Power Supply.	6
17	VeeT	Module Transmitter Ground.	1
18	TD+	Transmitter Non-Inverted Data Output (SFI).	
19	TD-	Transmitter Inverted Data Output (SFI).	
20	VeeT	Module Transmitter Ground.	1

Notes:

1. The module signal ground pins, VeeR and VeeT, are isolated from the module case.
2. This pin is an open drain output pin and shall be pulled up with 4.7kΩ to 10kΩ to the Host_Vcc on the host board. Pull-ups can be connected to multiple power supplies; however, the host board design

shall ensure that no module pin has voltage exceeding module $V_{ccT}/R+0.5V$.

3. This pin is an input pin with 10kΩ pull-up to the V_{ccT} in the module.
4. 2-Wire Electrical Specifications.
5. This pin shall be pulled up with 4.7kΩ to 10kΩ to the $Host_V_{cc}$ on the host board.
6. V_{ccT} and V_{ccR} are tied together inside the module.

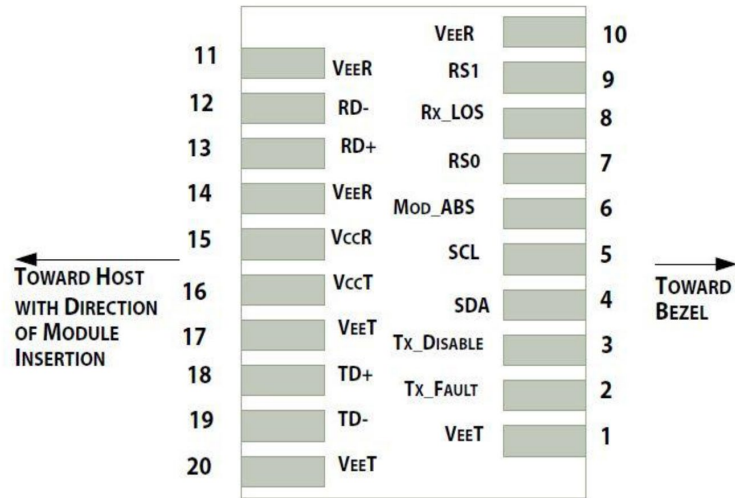

Pin-Out of Connector Block on the Host Board

Block Diagram

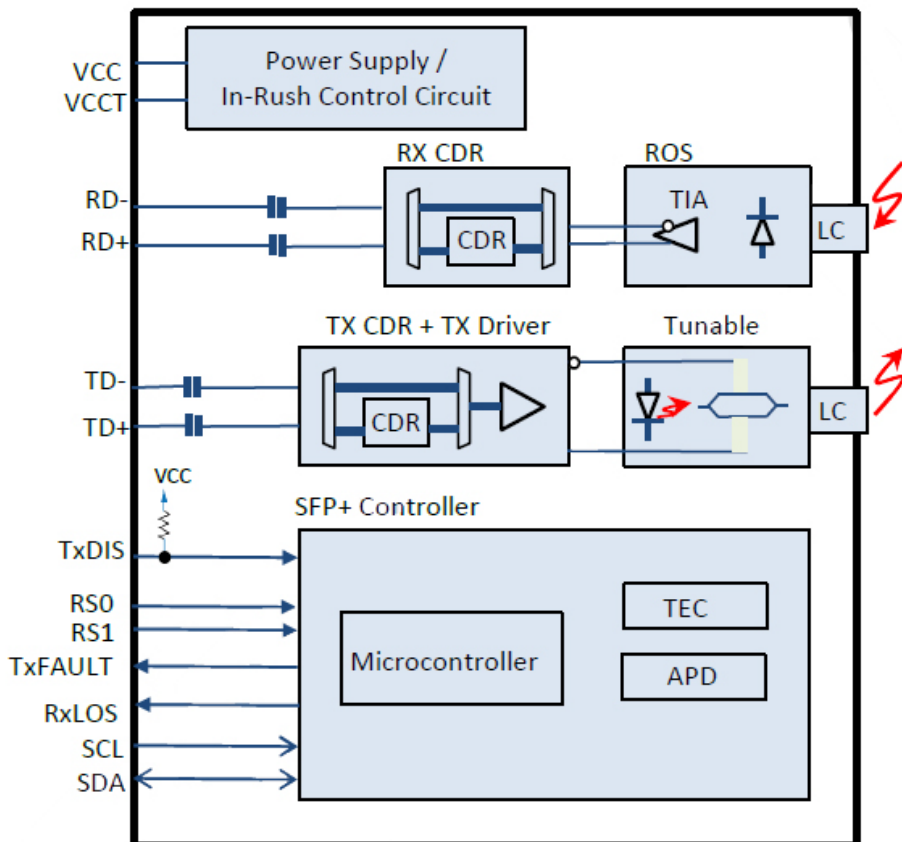

Interface to Host

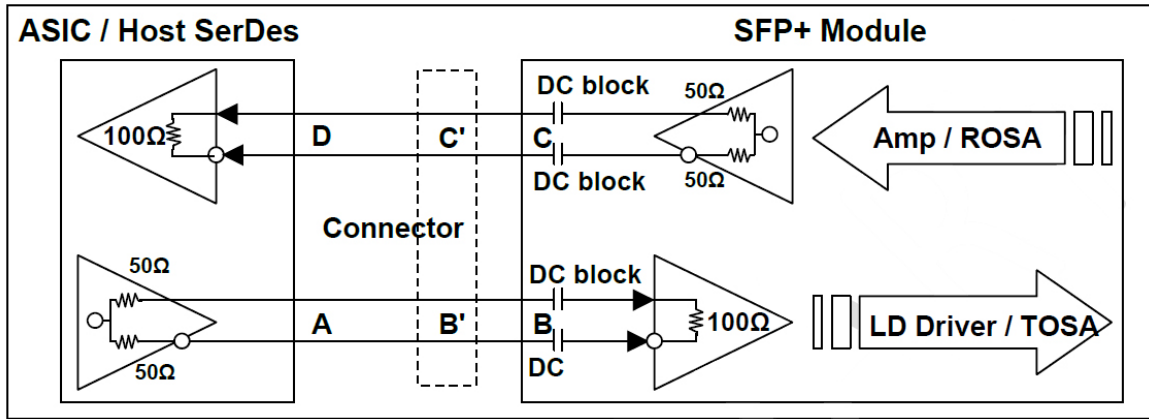

Mechanical Specifications

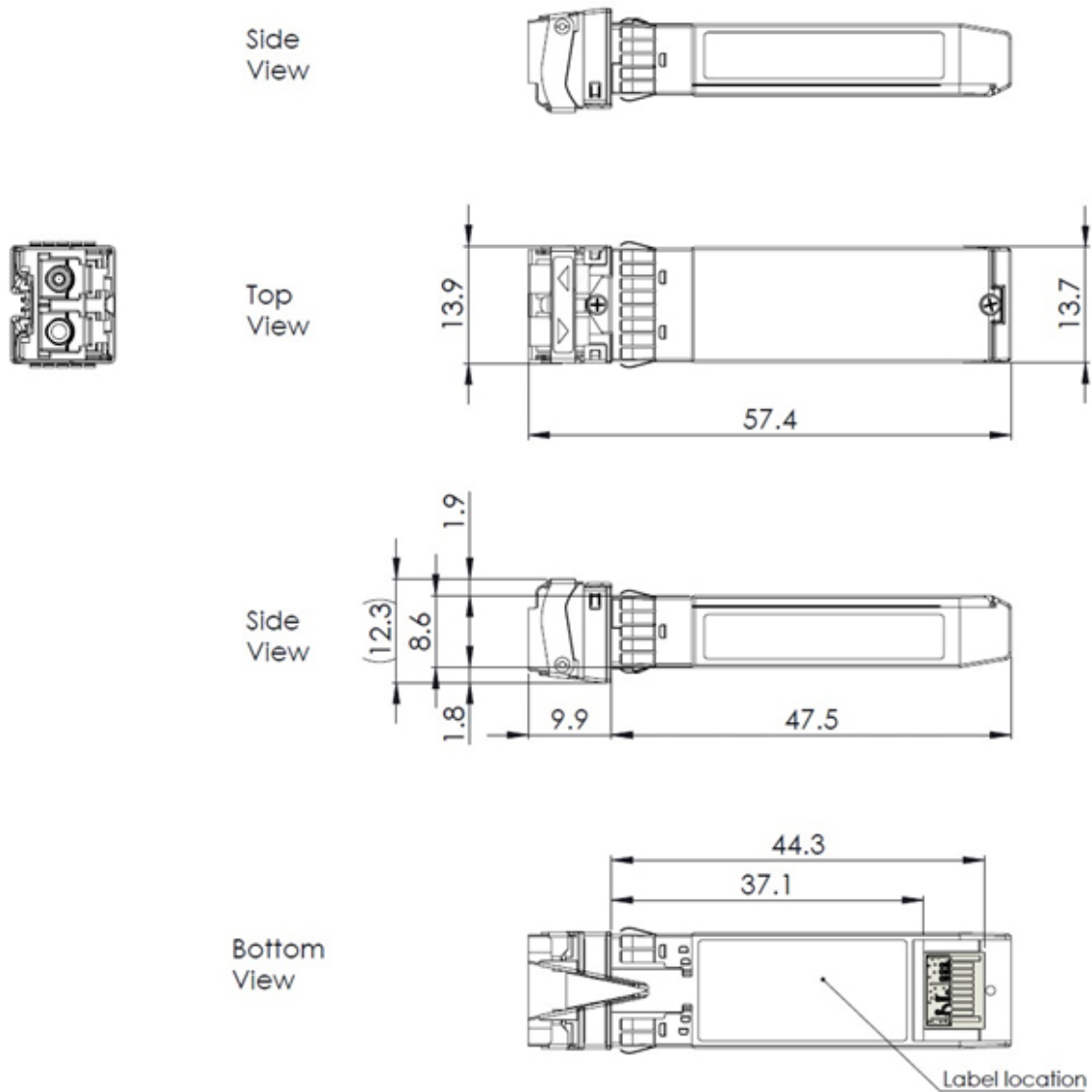

OptioConnect

Innovation for the Future of High-Speed Networking

Who We Are

OptioConnect is reshaping the landscape of communication and high-speed networking through intelligent technology. With a core focus on cutting edge technology, we deliver smarter fiber optic solutions for enterprise networks, data centers, and next-gen telecom infrastructures.

What We Do

At OptioConnect, we fuse advanced engineering with intelligent automation to drive the future of networking. Our AI-integrated solutions are designed to optimize performance and streamline operations with:

- Superior Performance
- Network and traffic optimization
- Intelligent energy management
- Seamless OEM compatibility
- Scalable cost-efficiency

Smarter Networks by Design

Innovation isn't just a goal—it's our process. We embed AI and machine learning across our R&D and product lines, enabling adaptive performance, automated tuning, and faster deployment cycles. The result? Networks that don't just work—they learn, evolve, and outperform.

Our Team

Our engineers, data scientists, and network architects bring decades of experience and a future-focused mindset. We provide hands-on support with intelligent insights that turn complex challenges into simple solutions.

Our Mission

To deliver AI-enhanced connectivity that reduces cost, increases speed, and maximizes efficiency—empowering our partners to operate at the forefront of a rapidly evolving digital world.

Let's Connect

Discover how OptioConnect's intelligent infrastructure solutions can power your network's next leap forward.

www.optioconnect.com | info@optioconnect.com

