

## QSFP56-200GB-4FR4-AR-C

Arista Networks® Compatible TAA 200GBase-FR4 QSFP56 Transceiver (SMF, 1310nm, 2km, LC, DOM, CMIS 4.0)

### Features:

- SFF-8661 Rev. 2.5 Compliant
- IEEE Std 802.3cn-2019 200GBASE-FR4 Compliant
- IEEE Std 802.3-2018 Section 8 200GAUI-4 Compliant
- 4x26.5625 GBd PAM4 Electrical Lanes into Optical Channels
- Cooled EA-DFB-LDs at Each CWDM 1.3µm Wavelength
- 4x PIN-PDs with TIA
- Single-Mode Fiber
- Duplex LC Connector
- Power Consumption is
- CMIS 4.0 Management Interface
- Commercial Temperature 0 to 70 Celsius
- RoHS Compliant and Lead-Free



### Applications:

- 200GBase Ethernet
- Access and Enterprise

### Product Description

This Arista Networks® compatible QSFP56 transceiver provides 200GBase-FR4 throughput up to 2km over single-mode fiber (SMF) using a wavelength of 1310nm via an LC connector. It is guaranteed to be 100% compatible with the equivalent Arista Networks® transceiver. It can operate at temperatures between 0 and 70C. All of our transceivers are built to comply with Multi-Source Agreement (MSA) standards and are uniquely serialized and tested for data-traffic and application to ensure seamless network integration. Additional product features include Digital Optical Monitoring (DOM) support which allows access to real-time operating parameters. This transceiver is Trade Agreements Act (TAA) compliant. We stand behind the quality of our products and proudly offer a limited lifetime warranty.

ProLabs' transceivers are RoHS compliant and lead-free.

TAA refers to the Trade Agreements Act (19 U.S.C. & 2501-2581), which is intended to foster fair and open international trade. TAA requires that the U.S. Government may acquire only "U.S.-made or designated country end products.")



## Absolute Maximum Ratings

Parameter	Symbol	Min.	Typ.	Max.	Unit	Notes
Maximum Supply Voltage	V <sub>cc</sub>	0		3.6	V	
Storage Temperature	T <sub>stg</sub>	-40		85	°C	
Operating Case Temperature	T <sub>c</sub>	0	25	70	°C	

### Notes:

- Stresses in excess of the Absolute Maximum Ratings can cause permanent damage to the device. These are absolute stress ratings only. Functional operation of the device is not implied at these or any other conditions in excess of those provided. Exposure to Absolute Maximum Ratings will cause permanent damage and/or adversely affect device reliability.

## Electrical Characteristics

Parameter	Symbol / Test Point	Min.	Typ.	Max.	Unit	Notes
Supply Voltage	V <sub>cc</sub>	3.135	3.3	3.465	V	
Module Power Supply Noise Tolerance	PSNR <sub>mod</sub>			66	mV	1
Power Consumption	PD			6.5	W	
Instantaneous Peak Current	I <sub>cc_ip</sub>			2600	mA	2
Sustained Peak Current	I <sub>cc_sp</sub>			2145.2	mA	2
Supply Current	I <sub>cc</sub>			2073.4	mA	3
<b>Transmitter Per Lane</b>						
Signaling Rate Per Lane (Range)	TP4	26.5625 ± 100ppm			GBd	4
AC Common-Mode Output Voltage (RMS)	TP4			17.5	mV	
Differential Pk-Pk Output Voltage	TP4			900	mV	
Near-End Eye Symmetry Mask Width (ESMW)	TP4	0.265			UI	
Near-End Eye Height Differential	TP4	70			mV	
Far-End Eye Symmetry Mask Width (ESMW)	TP4	0.2			UI	
Far-End Eye Height Differential	TP4	30			mV	
Far-End Pre-Cursor ISI Ratio	TP4	-4.5		2.5	%	
Differential Output Return Loss	TP4	Equation (83E-2)			dB	5
Common to Differential Mode Conversion Return Loss	TP4	Equation (83E-3)			dB	5
Differential Termination Mismatch	TP4			10	%	
Transition Time (20-80%)	TP4	9.5			ps	
DC Common-Mode Voltage	TP4	-350		2850	mV	

Receiver Per Lane						
Signaling Speed Per Lane (Range)		26.5625 ± 100ppm			GBd	
Differential Pk-Pk Input Voltage Tolerance	TP1a	900			mV	
Differential Input Return Loss	TP1	Equation (83E-5)			dB	5
Differential to Common-Mode Input Return Loss	TP1	Equation (83E-6)			dB	5
Differential Termination Mismatch	TP1			10	%	
Eye Symmetry Mask Width (ESMW)	TP1a	0.22			UI	
Eye Width	TP1a	0.22			UI	
Applied Pk-Pk Sinusoidal Jitter	TP1a	Table 120E-6			MHz, UI	
Eye Height	TP1a	32			mV	
Single-Ended Input Voltage Tolerance Range	TP1a	-0.4		3.3	V	
DC Common-Mode Voltage	TP1	-350		2850	mV	

**Notes:**

1. 10Hz to 10MHz.
2. Instantaneous and sustained peak currents for Icc host.

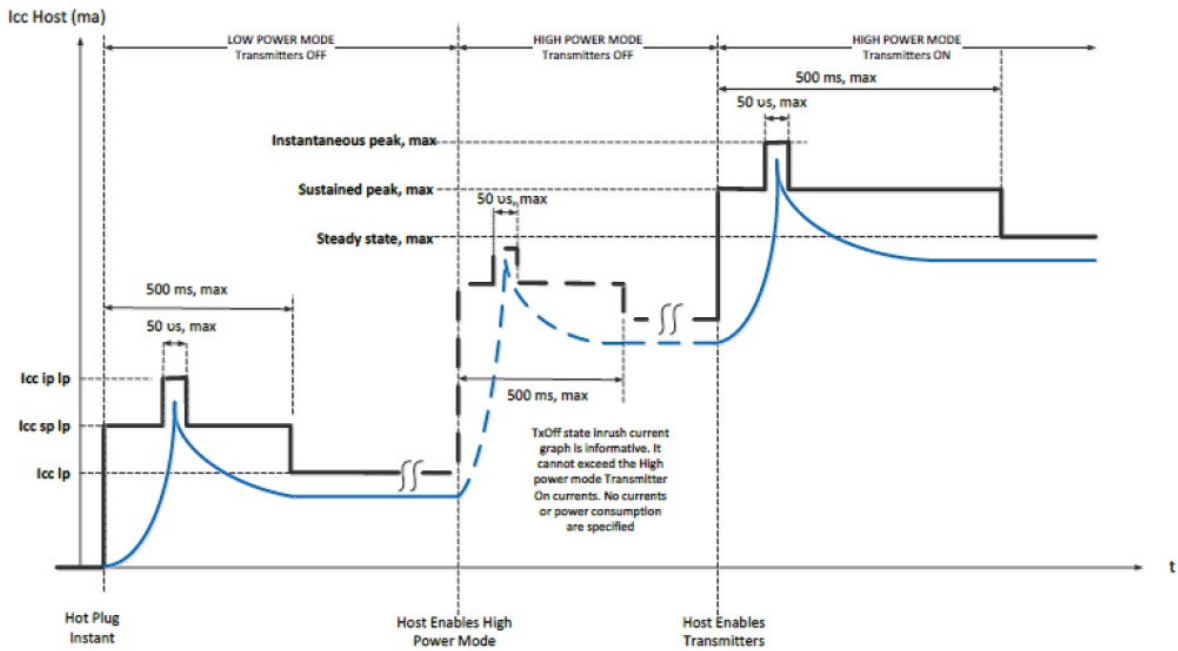

3. Steady state.
4. Electrical module output is squelched for loss of optical input signal.
5. IEEE Std 802.3-2018 Section 6.

## Optical Characteristics

Parameter	Symbol	Min.	Typ.	Max.	Unit	Notes	
Channel Data Rate	fDC		53.125		Gbps		
Signaling Rate Per Lane	fSG		26.5625		GBd	1	
Signal Speed Variation from Nominal Per Lane	fSG	-100		100	ppm		
Optical Receiver Input				+5.7	dBm	2	
Lane Wavelengths (Range)	Lane 0	$\lambda_{C0}$	1264.5		1277.5	nm	
	Lane 1	$\lambda_{C1}$	1284.5		1297.5	nm	
	Lane 2	$\lambda_{C2}$	1304.5		1317.5	nm	
	Lane 3	$\lambda_{C3}$	1324.5		1337.5	nm	
<b>Transmitter</b>							
Side-Mode Suppression Ratio	SMSR	30			dB		
Total Average Launch Power				10.7	dBm		
Average Launch Power Per Lane		-4.2		4.7	dBm	3	
Outer Optical Modulation Amplitude (OMA <sub>outer</sub> ) Per Lane		-1.2		4.5	dBm	4	
Difference in Launch Power Between Any Two Lanes (OMA <sub>outer</sub> )				4	dB		
Launch Power in OMA <sub>outer</sub> Minus TDECQ Per Lane	For ER $\geq$ 4.5dB		-2.6		dBm		
	For ER $<$ 4.5dB		-2.5		dBm		
Transmitter and Dispersion Eye Closure for PAM4 Per Lane	TDECQ			3.1	dB		
TDECQ – 10log <sub>10</sub> (Ceq) Per Lane				3.1	dB	5	
Average Launch Power of Off Transmitter Per Lane	Poff			-30	dBm		
Extinction Ratio Per Lane	ER	3.5			dB		
RIN <sub>15.6</sub> OMA				-132	dB/Hz		
Optical Return Loss Tolerance				17.1	dB		
Transmitter Reflectance				-26	dB	6	
<b>Receiver</b>							
Average Receive Power Per Lane		-8.2		4.7	dBm	7	
Receive Power (OMA <sub>outer</sub> ) Per Lane				4.5	dBm		
Difference in Receive Power Between Any Two Lanes (OMA <sub>outer</sub> )				4.1	dB		
Receiver Reflectance				-26	dB		
Receiver Sensitivity (OMA <sub>outer</sub> ) Per Lane				Max. (-5.5, SECQ – 6.9)	dBm	8, 9, 10	
Stressed Receiver Sensitivity (OMA <sub>outer</sub> ) Per Lane				-3.8	dBm	8, 11	
Receiver Loss of Signal Indicator Assert Level	Rx_LOS	-30		-11.2	dBm	12	
Receiver Loss of Signal Indicator De-Assert Level	Rx_LOS			-8.2	dBm	12	

Hysteresis	Rx_LOS	0.5			dB	
<b>Conditions of Stressed Receiver Sensitivity Test</b>						
Stressed Eye Closure For PAM4 Per Lane Under Test	SECQ		3.1		dB	13
SECQ – $10\log_{10}(\text{Ceq})$ Per Lane Under Test			3.1		dB	5, 13
OMA <sub>outer</sub> of Each Aggressor Lane			0.3		dBm	13

**Notes:**

1. PAM4.
2. Average per lane.
3. Average launch power, per lane (minimum), is informative and not the principal indicator of signal strength. A transmitter and launch power below this value cannot be compliant; however, a value above this does not ensure compliance.
4. Even if the TDECQ < 1.4dB for an extinction ratio of  $\geq 4.5\text{dB}$  or TDECQ < 1.3dB for an extinction ratio of < 4.5dB, the OMA<sub>outer</sub> (minimum) must exceed this value.
5. Ceq is a coefficient defined in IEEE Std 802.3-2018 Clause 121.8.5.3 which accounts for reference equalizer noise enhancement.
6. Transmitter reflectance is defined looking into the transmitter.
7. Average receive power, per lane (minimum), is informative and not the principal indicator of signal strength. A received power below this value cannot be compliant; however, a value above this does not ensure compliance.
8. For when pre-FEC BER is  $2.4 \times 10^{-4}$ .
9. Receiver sensitivity (OMA<sub>outer</sub>), per lane (maximum), is informative and is defined for a transmitter with a value of SECQ up to 3.1dB.
10. Illustration of receiver sensitivity for 200GBASE-FR4:

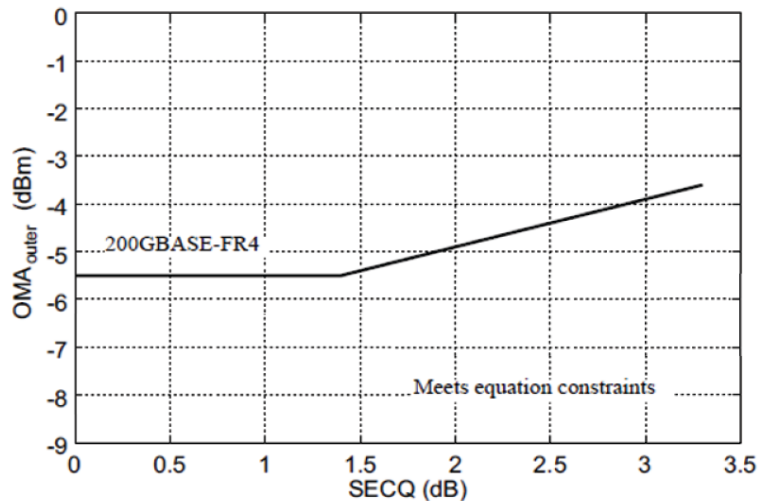

11. Measured with conformance test signal at TP3 (see IEEE Std 802.3-2018 Clause 122.8.9) for the BER specified in IEEE Std 802.3-2018 Clause 122.1.1.
12. Average power.
13. These test conditions are for measuring stressed receiver sensitivity. They are not characteristics of the receiver.

## Pin Descriptions

Pin	Logic	Symbol	Name/Description	Plug Sequence	Notes
1		GND	Module Ground.	1	1
2	CML-I	Tx2-	Transmitter Inverted Data Input.	3	
3	CML-I	Tx2+	Transmitter Non-Inverted Data Input.	3	
4		GND	Module Ground.	1	1
5	CML-I	Tx4-	Transmitter Inverted Data Input.	3	
6	CML-I	Tx4+	Transmitter Non-Inverted Data Input.	3	
7		GND	Module Ground.	1	1
8	LVTTL-I	ModSelL	Module Select.	3	
9	LVTTL-I	ResetL	Module Reset.	3	
10		VccRx	+3.3V Receiver Power Supply.	2	2
11	LVC MOS-I/O	SCL	2-Wire Serial Interface Clock.	3	
12	LVC MOS-I/O	SDA	2-Wire Serial Interface Data.	3	
13		GND	Module Ground.	1	1
14	CML-O	Rx3+	Receiver Non-Inverted Data Output.	3	
15	CML-O	Rx3-	Receiver Inverted Data Output.	3	
16		GND	Module Ground.	1	1
17	CML-O	Rx1+	Receiver Non-Inverted Data Output.	3	
18	CML-O	Rx1-	Receiver Inverted Data Output.	3	
19		GND	Module Ground.	1	1
20		GND	Module Ground.	1	1
21	CML-O	Rx2-	Receiver Inverted Data Output.	3	
22	CML-O	Rx2+	Receiver Non-Inverted Data Output.	3	
23		GND	Module Ground.	1	1
24	CML-O	Rx4-	Receiver Inverted Data Output.	3	
25	CML-O	Rx4+	Receiver Non-Inverted Data Output.	3	
26		GND	Module Ground.	1	1
27	LVTTL-O	ModPrsL	Module Present.	3	
28	LVTTL-O	IntL/RxLOSL	Interrupt. Optionally configurable as RxLOSL via the management interface (SFF-8636).	3	
29		VccTx	+3.3V Transmitter Power Supply.	2	2
30		Vcc1	+3.3V Power Supply.	2	2
31	LVTTL-I	LPMoDe/TxDis	Low-Power Mode. Optionally configurable as TxDis via the management interface (SFF-8636).	3	
32		GND	Module Ground.	1	1
33	CML-I	Tx3+	Transmitter Non-Inverted Data Input.	3	
34	CML-I	Tx3-	Transmitter Inverted Data Input.	3	

35		GND	Module Ground.	1	1
36	CML-I	Tx1+	Transmitter Non-Inverted Data Input.	3	
37	CML-I	Tx1-	Transmitter Inverted Data Input.	3	
38		GND	Module Ground.	1	1

**Notes:**

1. GND is the symbol for signal and supply (power) common for the module. All are common within the module, and all module voltages are referenced to this potential unless otherwise noted. Connect them directly to the host board signal-common ground plane.
2. VccRx, Vcc1, and VccTx are applied concurrently and may be internally connected within the module in any combination. Vcc contacts in SFF-8662 and SFF-8672 each have a steady state current rating of 1A.

**Electrical Pin-Out Details**

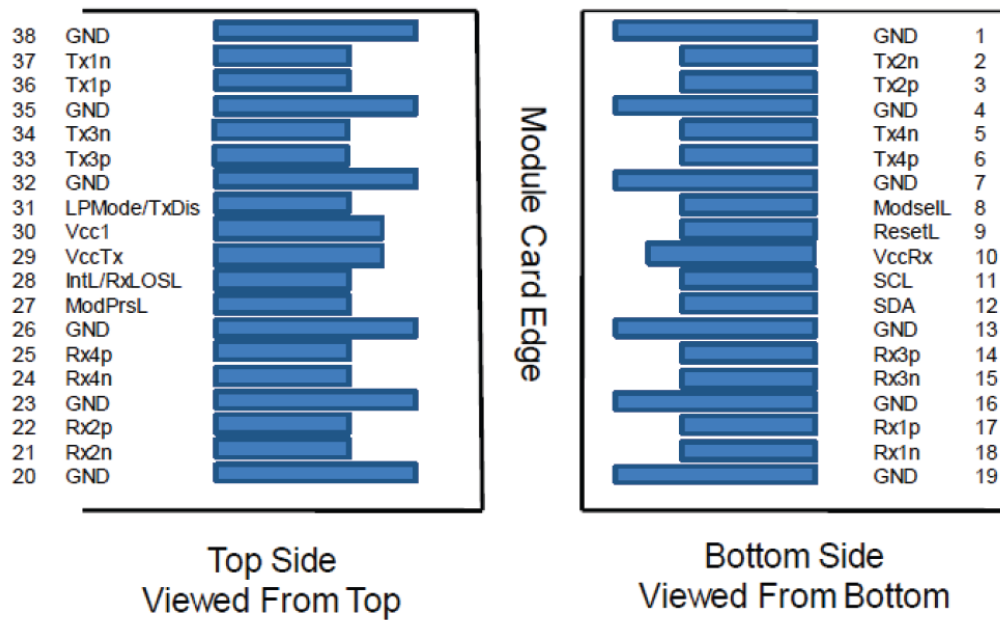

## Recommended Host Board Power Supply Filtering

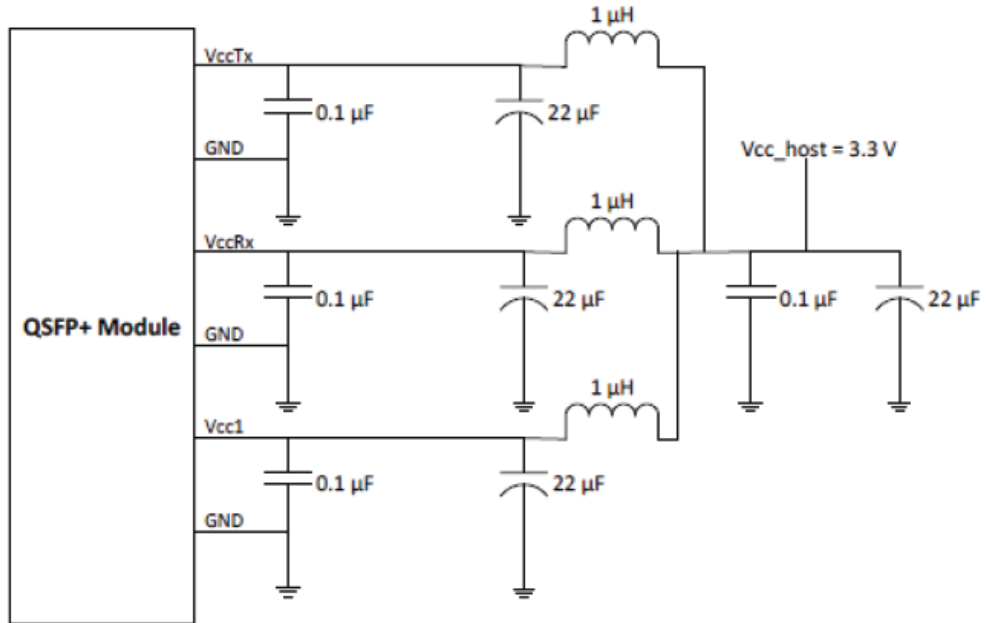

## Functional Block Diagram

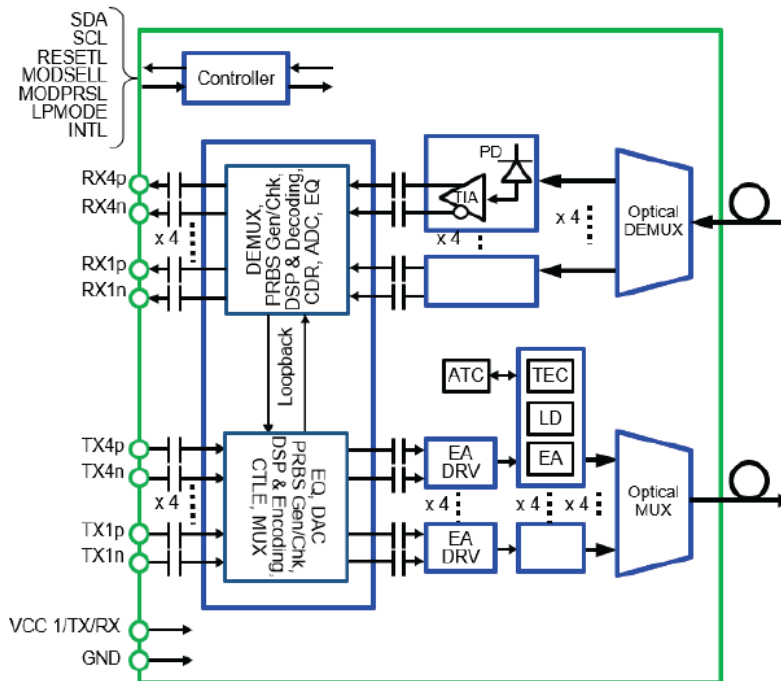

## Mechanical Specifications

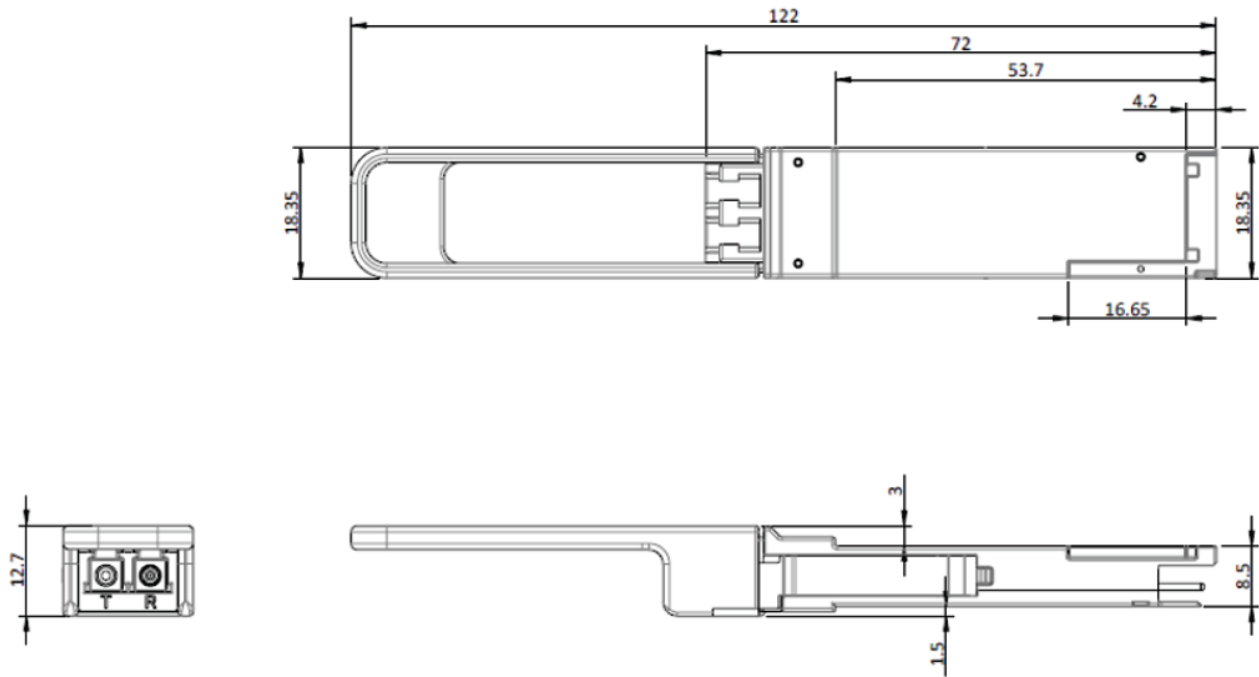

### Notes:

1. All dimensions are measured in mm.
2. Green pull tab.

## Case Temperature Measurement Point

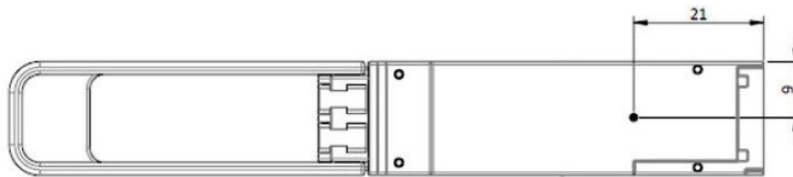

## Optical Interface

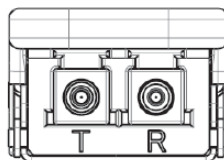

### Notes:

1. Looking into the connector, the transmitter is on the left.

## About ProLabs

Our extensive experience comes as standard. For over 20 years ProLabs has delivered optical connectivity solutions that give our customers freedom and choice through our ability to provide seamless interoperability. At the heart of our company is the ability to provide state-of-the-art optical transport and connectivity solutions that are compatible with more than 100 optical switching and transport platforms.

## A Complete Portfolio of Network Solutions

ProLabs is focused on innovations in optical transport and connectivity. The combination of our knowledge of optics and networking equipment enables ProLabs to be your single source for optical transport and connectivity solutions from 100Mb to 1.6T while providing innovative solutions that increase network efficiency. We provide the optical connectivity expertise that is compatible with and enhances your switching and transport equipment.

## The Trusted Partner

Customer service is our number one value. ProLabs has invested in people, labs and manufacturing capacity to ensure compatible products, and immediate answers to your questions. With Engineering and Manufacturing offices in the U.K. and U.S. augmented by field offices throughout the U.S., U.K. and Asia, ProLabs is able to be our customers best advocate 24 hours a day.



## Contact Information

ProLabs US

Email: [sales@prolabs.com](mailto:sales@prolabs.com)

Telephone: 952-852-0252

ProLabs UK

Email: [salessupport@prolabs.com](mailto:salessupport@prolabs.com)

Telephone: +44 1285 719 600