

### OSFP-800GB-2XDR4-LPO-AR-C

Arista Networks® Compatible TAA 800GBase-2xDR4 PAM4 OSFP-IHS Transceiver (SMF, 1310nm, 500m, 2xMPO-12, DOM, CMIS 5.0) LPO

#### Features:

- OSFP MSA Compliant
- Dual MPO-12 Connector APC
- Supports 106.25Gbps Data Rate Per Channel
- Integrated Silicon Photonics Modulator Chip 1310nm High-Power DFB Laser
- 1310nm PIN Array for up to 500m Reach over SMF
- Electrically Hot-Pluggable
- Single 3.3V Power Supply
- Operating Temperature: 0 to 70 Celsius
- RoHS Compliant and Lead-Free



#### Applications:

- 800GBase Ethernet

#### Product Description

This Arista Networks® compatible OSFP-IHS Transceiver provides 800GBase-2xDR4 throughput up to 500m over single-mode fiber (SMF) PAM4 using a wavelength of 1310nm via a 2xMPO-12 connector. It can operate at temperatures between 0 and 70C. All of our transceivers are built to comply with Multi-Source Agreement (MSA) standards and are uniquely serialized and tested for data-traffic and application to ensure seamless network integration. Additional product features include Digital Optical Monitoring (DOM) support which allows access to real-time operating parameters. This transceiver is Trade Agreements Act (TAA) compliant. We stand behind the quality of our products and proudly offer a limited lifetime warranty.

ProLabs' transceivers are RoHS compliant and lead-free.

TAA refers to the Trade Agreements Act (19 U.S.C. & 2501-2581), which is intended to foster fair and open international trade. TAA requires that the U.S. Government may acquire only "U.S.-made or designated country end products."



## Absolute Maximum Ratings

Parameter	Symbol	Min.	Typ.	Max.	Unit	Notes
Power Supply Voltage	Vcc	-0.5		3.6	V	
Storage Temperature	Tstg	-40		85	°C	
Operating Case Temperature	Tc	0		70	°C	1
Relative Humidity	RH	5		85	%	
Optical Receiver Damage Threshold Input	Pdmg	5.0			dBm	
Data Rate	DR		53.125 @ PAM4		Gbps	2
Transmission Distance	TD			500	M	
Coupled Fiber		Single-Mode Fiber				3
Power Supply Voltage	Vcc	3.135	3.3	3.465	V	
Power Supply Current	Icc			2424	mA	4

### Notes:

1. Without air flow.
2. Each optical channel.
3. 9/125µm SMF.
4. When Vcc is 3.3V.

## Link Power Budget

Parameter	Symbol	Min.	Typ.	Max.	Unit	Notes
Power Budget for Maximum TDECQ			7.8		dB	
Operating Distance			500		m	
Channel Insertion Loss			4		dB	
Allocation for Penalties for Maximum TDECQ			3.8		dB	

## Optical Characteristics

Parameter	Symbol	Min.	Typ.	Max.	Unit	Notes
<b>Transmitter</b>						
Signaling Speed Per Lane			53.125 ± 100ppm		GBd	
Modulation Format			PAM4			
Lane Wavelengths	$\lambda$	1304.5		1317.5	nm	1
Average Launch Power Per Lane		-2.9		4.0	dBm	
Transmit OMA Per Lane		-0.8		4.2	dBm	
Transmitter and Dispersion Eye Closure for PAM4 (TDECQ) Per Lane	TDECQ			3.4	dB	
SMSR		30			dB	
Optical Extinction Ratio	ER	3.5			dB	
Average Launch Power Off Per Lane	Poff			-15	dBm	
RIN <sub>17.1</sub> OMA (Maximum)	RIN			-136	dB/Hz	
Transmitter Reflectance	TR			-26	dB	
<b>Receiver</b>						
Signaling Speed Per Lane			53.125 ± 100ppm		GBD	
Modulation Format			PAM4			
Lane Wavelengths	$\lambda$	1304.5		1317.5	nm	1
Damage Threshold Per Lane		5.0			dBm	2
Receive Power (OMA) Per Lane	ROMA			4.2	dBm	
Average Input Power Per Channel	RXpx	-5.9		4.0	dBm	
Receiver Sensitivity (OMA) Per Lane	RXsens			-4.4	dBm	3
Receiver Reflectance	RR			-26	dB	

### Notes:

1. The wavelength assignment is suitable for all channels.
2. Measured with PRBS31Q test pattern and BER@ $2.4 \times 10^{-4}$ .
3. The receiver shall be able to tolerate, without damage, continuous exposure to an optical input signal having this average power level.

## Pin Descriptions

Pin	Symbol	Name/Description	Notes
1	GND	Module Ground.	1
2	Tx2+	Transmitter Non-Inverted Data.	
3	Tx2-	Transmitter Inverted Data.	
4	GND	Module Ground.	1
5	Tx4+	Transmitter Non-Inverted Data.	
6	Tx4-	Transmitter Inverted Data.	
7	GND	Module Ground.	1
8	Tx6+	Transmitter Non-Inverted Data.	
9	Tx6-	Transmitter Inverted Data.	
10	GND	Module Ground.	1
11	Tx8+	Transmitter Non-Inverted Data.	
12	Tx8-	Transmitter Inverted Data.	
13	GND	Module Ground.	1
14	SCL	2-Wire Serial Interface Clock.	2
15	Vcc	+3.3V Power Supply.	
16	Vcc	+3.3V Power Supply.	
17	LPWn/PRSn	Low-Power Mode/Module Present.	
18	GND	Module Ground.	1
19	Rx7-	Receiver Inverted Data.	
20	Rx7+	Receiver Non-Inverted Data.	
21	GND	Module Ground.	1
22	Rx5-	Receiver Inverted Data.	
23	Rx5+	Receiver Non-Inverted Data.	
24	GND	Module Ground.	1
25	Rx3-	Receiver Inverted Data.	
26	Rx3+	Receiver Non-Inverted Data.	
27	GND	Module Ground.	1
28	Rx1-	Receiver Inverted Data.	
29	Rx1+	Receiver Non-Inverted Data.	
30	GND	Module Ground.	1
31	GND	Module Ground.	1
32	Rx2+	Receiver Non-Inverted Data.	
33	Rx2-	Receiver Inverted Data.	
34	GND	Module Ground.	1
35	Rx4+	Receiver Non-Inverted Data.	
36	Rx4-	Receiver Inverted Data.	
37	GND	Module Ground.	1

38	Rx6+	Receiver Non-Inverted Data.	
39	Rx6-	Receiver Inverted Data.	
40	GND	Module Ground.	1
41	Rx8+	Receiver Non-Inverted Data.	
42	Rx8-	Receiver Inverted Data.	
43	GND	Module Ground.	1
44	INT/RSTn	Module Input/Module Reset.	
45	Vcc	+3.3V Power Supply.	
46	Vcc	+3.3V Power Supply.	
47	SDA	2-Wire Serial Interface Data.	2
48	GND	Module Ground.	1
49	Tx7-	Transmitter Inverted Data.	
50	Tx7+	Transmitter Non-Inverted Data.	
51	GND	Module Ground.	1
52	Tx5-	Transmitter Inverted Data.	
53	Tx5+	Transmitter Non-Inverted Data.	
54	GND	Module Ground.	1
55	Tx3-	Transmitter Inverted Data.	
56	Tx3+	Transmitter Non-Inverted Data.	
57	GND	Module Ground.	1
58	Tx1-	Transmitter Inverted Data.	
59	Tx1+	Transmitter Non-Inverted Data.	
60	GND	Module Ground.	1

**Notes:**

1. OSFP uses common ground (GND) for all signals and supply (power). All are common within the OSFP module, and all module voltages are referenced to this potential unless otherwise noted. Connect these directly to the host board signal common ground plane.
2. Open-drain with pull-up resistor on the host.

# Electrical Pad Layout

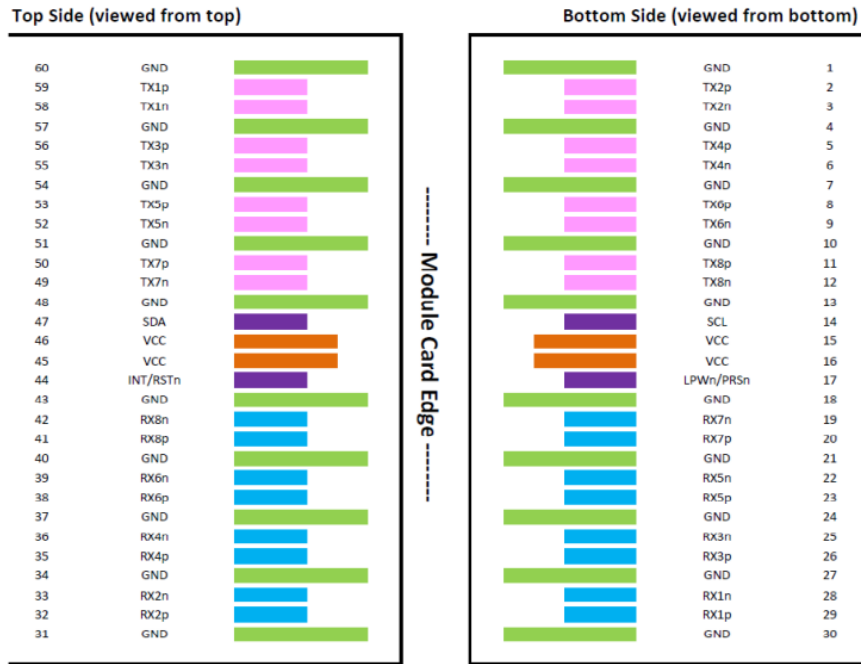

# Transceiver Block Diagram

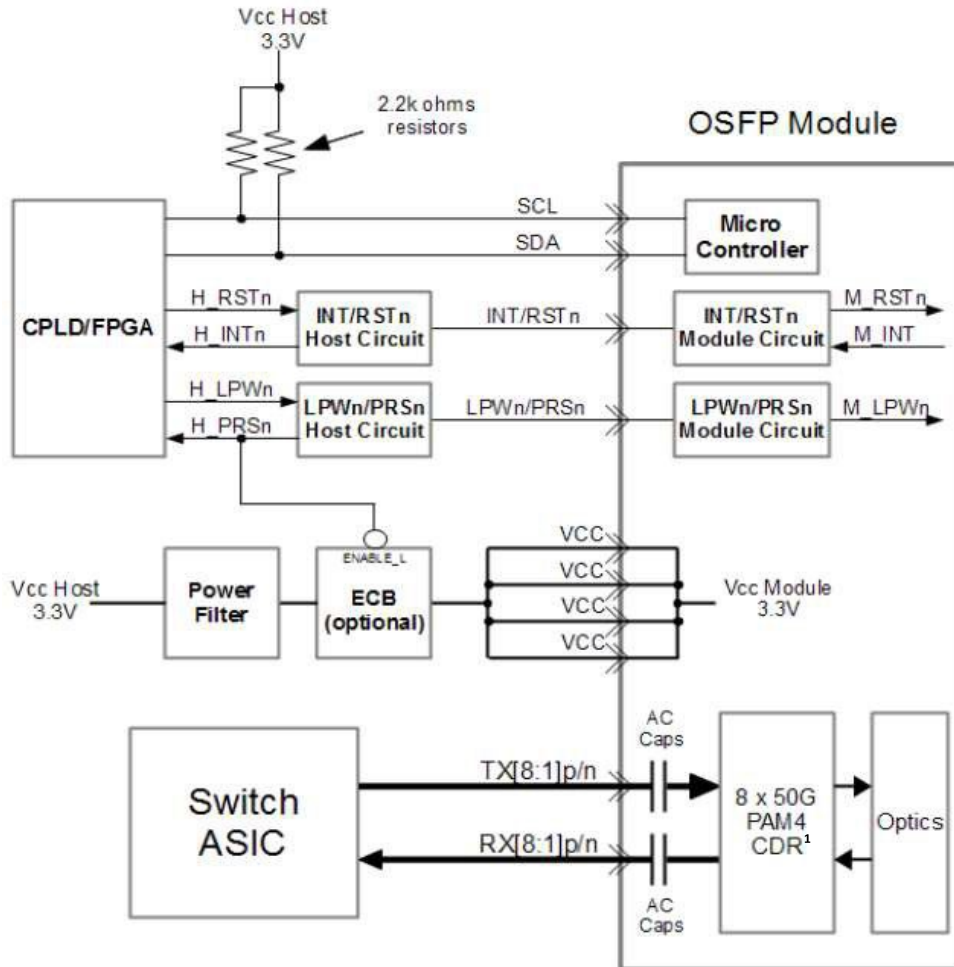

# Mechanical Specifications

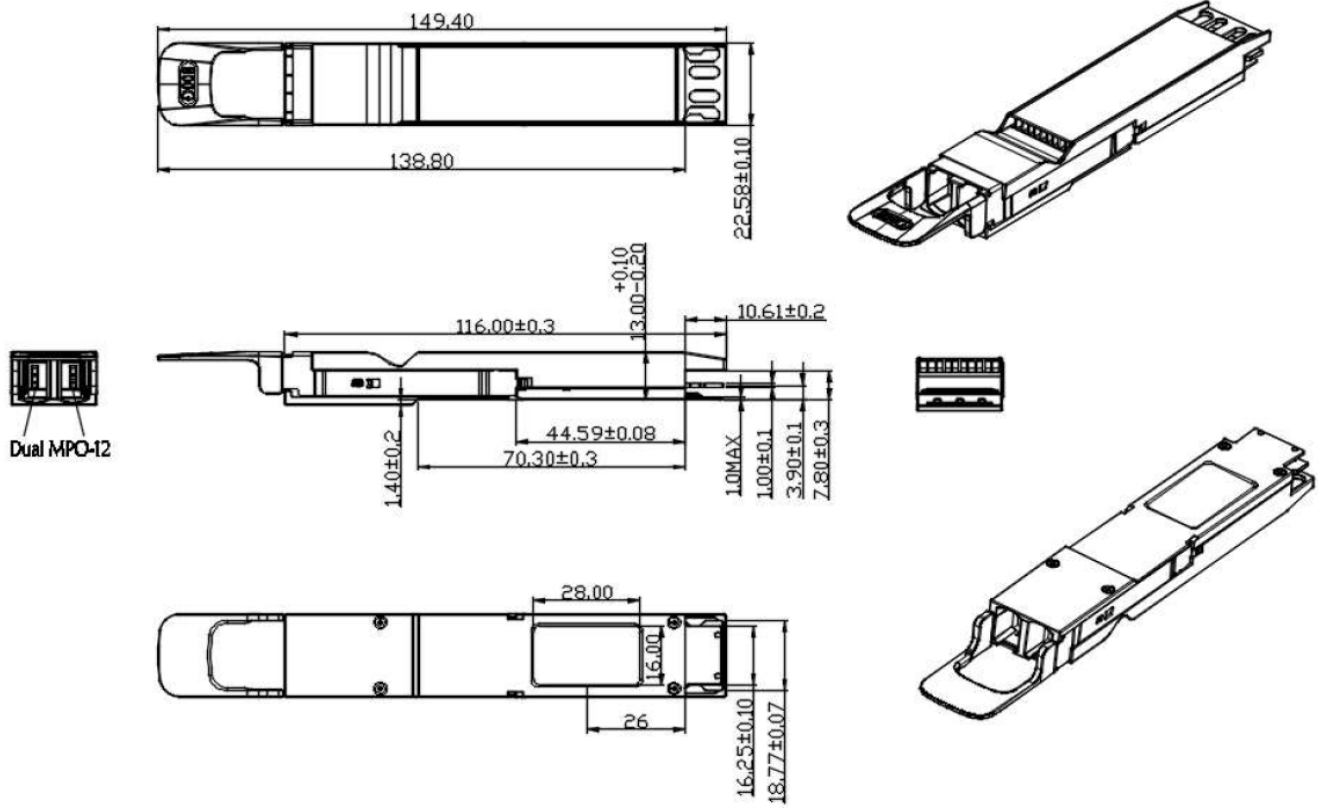

## About ProLabs

Our extensive experience comes as standard. For over 20 years ProLabs has delivered optical connectivity solutions that give our customers freedom and choice through our ability to provide seamless interoperability. At the heart of our company is the ability to provide state-of-the-art optical transport and connectivity solutions that are compatible with more than 100 optical switching and transport platforms.

## A Complete Portfolio of Network Solutions

ProLabs is focused on innovations in optical transport and connectivity. The combination of our knowledge of optics and networking equipment enables ProLabs to be your single source for optical transport and connectivity solutions from 100Mb to 1.6T while providing innovative solutions that increase network efficiency. We provide the optical connectivity expertise that is compatible with and enhances your switching and transport equipment.

## The Trusted Partner

Customer service is our number one value. ProLabs has invested in people, labs and manufacturing capacity to ensure compatible products, and immediate answers to your questions. With Engineering and Manufacturing offices in the U.K. and U.S. augmented by field offices throughout the U.S., U.K. and Asia, ProLabs is able to be our customers best advocate 24 hours a day.



## Contact Information

ProLabs US

Email: [sales@prolabs.com](mailto:sales@prolabs.com)

Telephone: 952-852-0252

ProLabs UK

Email: [salessupport@prolabs.com](mailto:salessupport@prolabs.com)

Telephone: +44 1285 719 600