

## SFP-10G-DZ-63.86-AO

Arista Networks® SFP-10G-DZ-63.86 Compatible TAA 10GBase-DWDM SFP+ Transceiver C-Band 100GHz (SMF, 1563.86nm, 80km, LC, DOM)

### Features

- SFF-8432 and SFF-8472 Compliance
- Temperature-stabilized EML transmitter and APD receiver
- Duplex LC Connector
- Commercial Temperature 0 to 70 Celsius
- Single-mode Fiber
- Hot Pluggable
- Excellent ESD Protection
- Metal with Lower EMI
- RoHS Compliant and Lead Free



### Applications

- 8x/10x Fibre Channel
- 10x Gigabit Ethernet over DWDM
- Access, Metro and Enterprise

### Product Description

This Arista Networks® SFP-10G-DZ-63.86 compatible SFP+ transceiver provides 10GBase-DWDM throughput up to 80km over single-mode fiber (SMF) using a wavelength of 1563.86nm via an LC connector. It can operate at temperatures between 0 and 70C. Our transceiver is built to meet or exceed OEM specifications and is guaranteed to be 100% compatible with Arista Networks®. It has been programmed, uniquely serialized, and tested for data-traffic and application to ensure that it will initialize and perform identically. All of our transceivers comply with Multi-Source Agreement (MSA) standards to provide seamless network integration. Additional product features include Digital Optical Monitoring (DOM) support which allows access to real-time operating parameters. This transceiver is Trade Agreements Act (TAA) compliant. We stand behind the quality of our products and proudly offer a limited lifetime warranty.

AddOn's transceivers are RoHS compliant and lead-free.

TAA refers to the Trade Agreements Act (19 U.S.C. & 2501-2581), which is intended to foster fair and open international trade. TAA requires that the U.S. Government may acquire only "U.S.-made or designated country end products."



### Wavelength Guide (100GHz ITU-T Channels)

ITU Channel #	Frequency (THz)	Center Wavelength (nm)
17	191.7	1563.86
18	191.8	1563.05
19	191.9	1562.23
20	192.0	1561.42
21	192.1	1560.61
22	192.2	1559.79
23	192.3	1558.98
24	192.4	1558.17
25	192.5	1557.36
26	192.6	1556.55
27	192.7	1555.75
28	192.8	1554.94
29	192.9	1554.13
30	193.0	1553.33
31	193.1	1552.52
32	193.2	1551.72
33	193.3	1550.92
34	193.4	1550.12
35	193.5	1549.32
36	193.6	1548.51
37	193.7	1547.72
38	193.8	1546.92
39	193.9	1546.12
40	194.0	1545.32
41	194.1	1544.53
42	194.2	1543.73
43	194.3	1542.94
44	194.4	1542.14
45	194.5	1541.35
46	194.6	1540.56
47	194.7	1539.77
48	194.8	1538.98
49	194.9	1538.19
50	195.0	1537.40

51	195.1	1536.61
52	195.2	1535.82
53	195.3	1535.04
54	195.4	1534.25
55	195.5	1533.47
56	195.6	1532.68
57	195.7	1531.90
58	195.8	1531.12
59	195.9	1530.33
60	196.0	1529.55

### Absolute Maximum Ratings

Parameter	Symbol	Min.	Typ.	Max.	Unit	Notes
Storage Temperature	Tstg	-40		85	°C	1
Maximum Supply Voltage	Vcc	-0.5		3.6	V	
Operating Relative Humidity	RH			95	%	
Power Budget		23			dB	
Data Rate			10.3125		Gbps	

### Notes:

1. Exceeding any one of these values may destroy the device permanently.

## Electrical Characteristics

Parameter	Symbol	Min.	Typ.	Max.	Unit	Notes
<b>Transmitter</b>						
CML Differential Inputs	VIN	150		1200	mVp-p	1
Input AC Common-Mode Voltage				25	mV	2
Input Differential Impedance	ZIN	85	100	115	Ω	3
Tx_Disable	High		2	Vcc	V	
	Low			0.8		
Tx_Fault	High		2	Vcc+0.3	V	4
	Low			0.5		5
<b>Receiver</b>						
CML Differential Outputs	VOUT	350		700	mVp-p	1
Output Differential Impedance	ZOUT	85	100	115	Ω	
Rx_LOS	High		2	Vcc+0.3		4
	Low			0.8		5
MOD_DEF(0.2)		VOH	2.5		V	
		VOL		0.5		6

### Notes:

1. AC coupled inputs.
2. RMS.
3. RIN>100kΩ @DC.
4. I<sub>o</sub> = 400μA; Host\_Vcc.
5. I<sub>o</sub> = -4.0mA.
6. With serial ID.

## Optical Characteristics

Parameter	Symbol	Min.	Typ.	Max.	Unit	Notes
<b>Transmitter</b>						
Operating Wavelength	$\lambda$	$\lambda-0.1$		$\lambda+0.1$	nm	
Spectral Width (-20dB)	$\Delta\lambda$			1	nm	
Average Output Power	POUT			4	dBm	1
Extinction Ratio	ER	7.5			dB	
Average Power of Off Transmitter	Poff			-30	dBm	
Relative Intensity Noise	RIN			-128	dB/Hz	
Side-Mode Suppression Ratio	SMSR	30			dB	
Transmitter Dispersion Penalty	TDP			3.0	dB	
Tx_Disable Assert Time	T_off			10	us	
<b>Receiver</b>						
Center Wavelength	$\lambda_C$	1260	$\lambda$	1600	nm	
Receiver Sensitivity	Pmin			-23	dBm	2
Receiver Overload	Pmax	-7			dBm	
LOS De-Assert	LOSD			-24	dBm	
LOS Assert	LOSA	-40			dBm	
LOS Hysteresis	LOSH	0.5			dB	

### Notes:

1. Output is coupled into a 9/125 $\mu$ m SMF.
2. Measured with worst ER, BER less than  $1E^{-12}$ , and PRBS  $2^{31}-1$  @10.3125Gbps.

## Pin Descriptions

Pin	Symbol	Name/Description	Plug Seq.	Notes
1	VeeT	Transmitter Ground.	1	5
2	Tx_Fault	Transmitter Fault Indication.	3	1
3	Tx_Disable	Transmitter Disable.	3	2, module disables on "high" or "open"
4	SDA	Transmitter Disable.	3	3, 2-wire serial ID interface
5	SCL	Module Definition 2.	3	3, 2-wire serial ID interface
6	MOD_ABS	Module Definition 1.	3	3
7	RS0	Rx Rate Select (LVTTTL).	3	NC
8	LOS	Loss of Signal.	3	4
9	RS1	Tx Rate Select (LVTTTL).	1	NC
10	VeeR	Receiver Ground.	1	5
11	VeeR	Receiver Ground.	1	5
12	RD-	Inverted Received Data Out.	3	6
13	RD+	Received Data Out.	3	6
14	VeeR	Receiver Ground.	1	5
15	VccR	Receiver Power.	2	7, 3.3V ± 5%
16	VccT	Transmitter Power.	2	7, 3.3V ± 5%
17	VeeT	Transmitter Ground.	1	5
18	TD+	Transmit Data In.	3	8
19	TD-	Inverted Transmit Data In.	3	8
20	VeeT	Transmitter Ground.	1	5

### Notes:

- Tx\_Fault is an open collector/drain output that should be pulled up with a 4.7kΩ to 10kΩ resistor on the host board. Pull-up voltage is between 2.0V and VccT/R+0.3V. When "high," the output indicates a laser fault of some kind. "Low" indicates normal operation. In the "low" state, the output will be pulled to <0.8V.
- Tx\_Disable is an input that is used to shut down the transmitter optical output. It is pulled up within the module with a 4.7kΩ to 10kΩ resistor. It states are:
  - Low (0V-0.8V): Transmitter On
  - (>0.8V, <2.0V): Undefined
  - High (2.0V-3.465V): Transmitter Disabled
  - Open: Transmitter Disabled.
- Modulation absent. Connected to the VeeT or VeeR in the module.
- LOS (Loss of Signal) is an open collector/drain output that should be pulled up with a 4.7kΩ to 10kΩ resistor. Pull-up voltage between 2.0V and VccT/R+0.3V. When "high," this output indicates that the received optical power is below the worst-case receiver sensitivity (as defined by the standard in use). "Low" indicates normal operation. In the "low" state, the output will be pulled to <0.8V.
- VeeR and VeeT may be internally connected within the SFP module.
- RD-/+. These are the differential receiver outputs. They are AC-coupled, 100 differential lines that should be

terminated with 100 (differential) at the user SERDES. The AC coupling is done inside the module and is thus not required on the host board. The voltage swing on these lines will be between 400mV and 2000mV differential (200mV–1000mV single-ended) when properly terminated.

7. VccR and VccT are the receiver and transmitter power supplies. They are defined as 3.3V±5% at the SFP connector pin. Maximum supply current is 545mA. Recommended host board power supply filtering is shown below. Inductors with DC resistance of less than 1Ω should be used to maintain the required voltage at the SFP input pin with 3.3V supply voltage. When the recommended supply-filtering network is used, hot-plugging of the SFP transceiver module will result in an in-rush current of no more than 30mA greater than the steady state value. VccR and VccT may be internally connected within the SFP transceiver module.
8. TD-/+. These are the differential transmitter inputs. They are AC-coupled, differential lines with 100Ω differential termination inside the module.

### Electrical Pin-Out Details

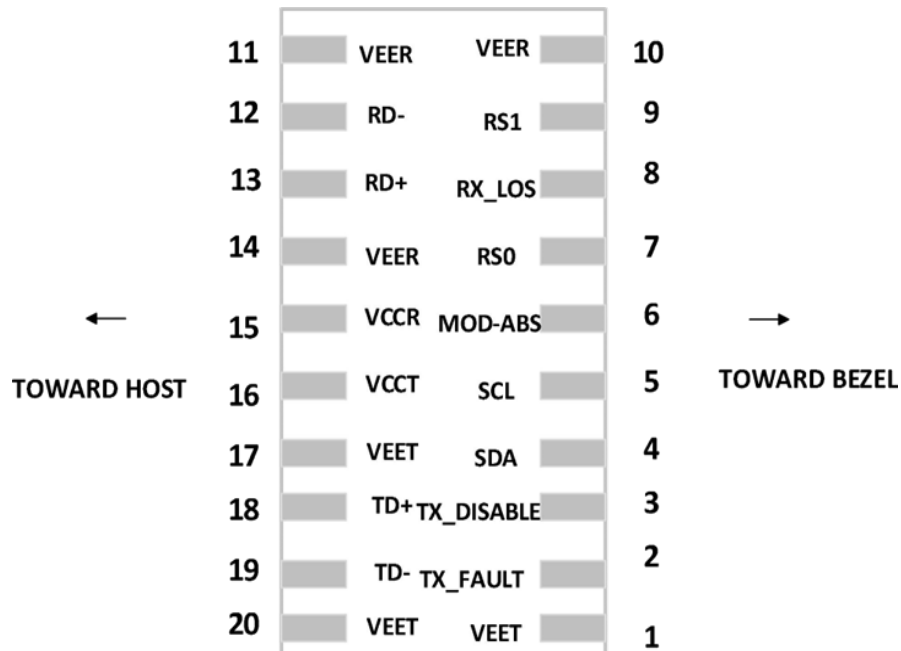

# Recommend Circuit Schematic

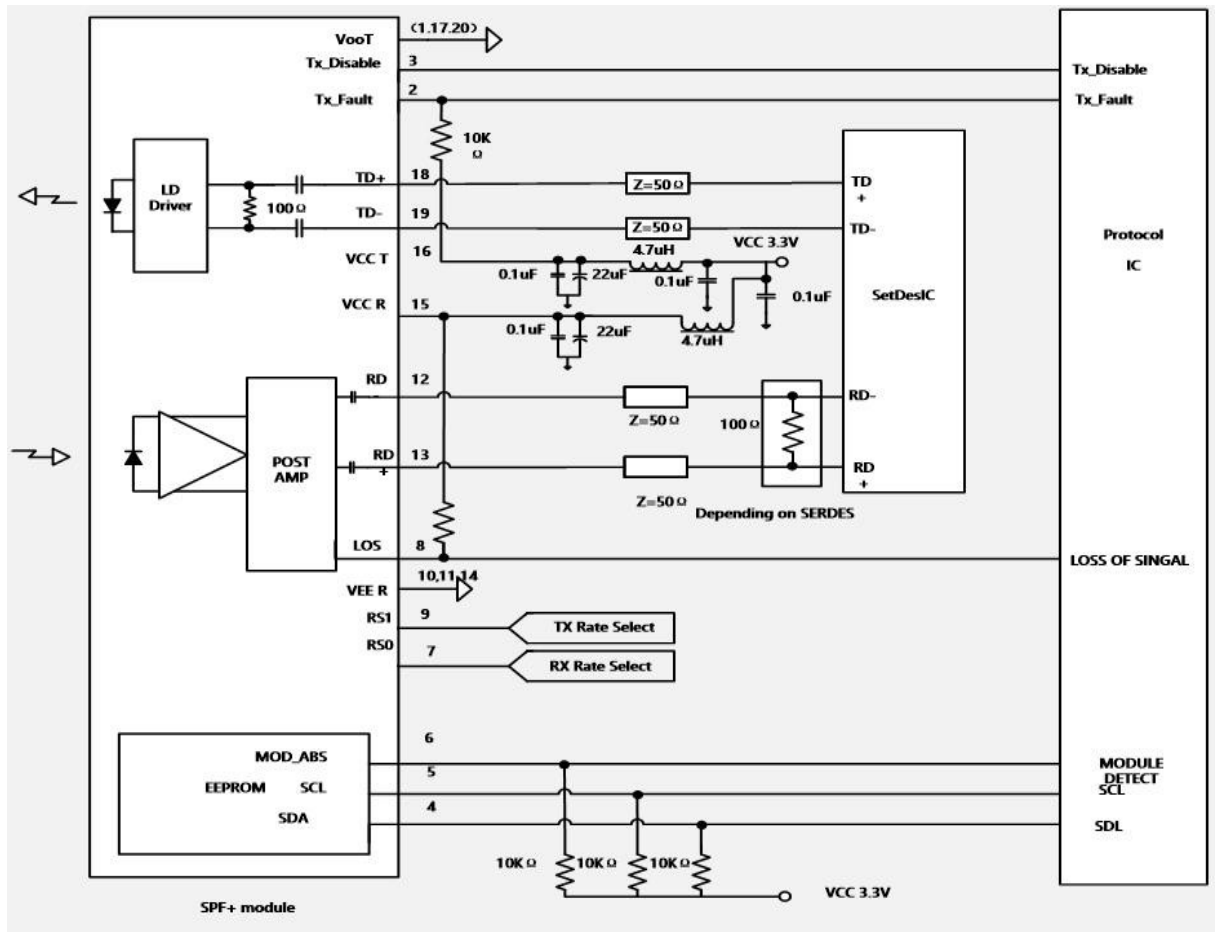

## Mechanical Specifications

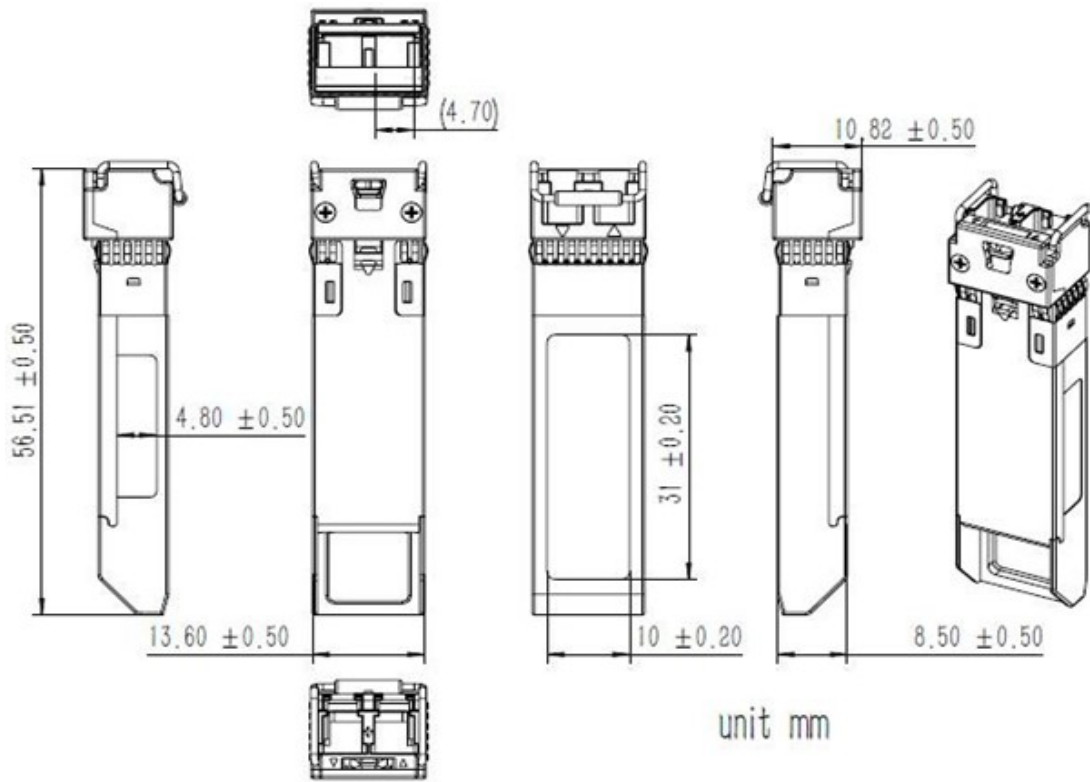

## About AddOn Networks

In 1999, AddOn Networks entered the market with a single product. Our founders fulfilled a severe shortage for compatible, cost-effective optical transceivers that compete at the same performance levels as leading OEM manufacturers. Adhering to the idea of redefining service and product quality not previously had in the fiber optic networking industry, AddOn invested resources in solution design, production, fulfillment, and global support.

Combining one of the most extensive and stringent testing processes in the industry, an exceptional free tech support center, and a consistent roll-out of innovative technologies, AddOn has continually set industry standards of quality and reliability throughout its history.

Reliability is the cornerstone of any optical fiber network and is ingrained in AddOn's DNA. It has played a key role in nurturing the long-term relationships developed over the years with customers. AddOn remains committed to exceeding industry standards with certifications ranging from NEBS Level 3 to ISO 9001:2015 with every new development while maintaining the signature reliability of its products.



## U.S. Headquarters

Email: [sales@addonnetworks.com](mailto:sales@addonnetworks.com)

Telephone: +1 877.292.1701

Fax: 949.266.9273

## Europe Headquarters

Email: [salesemea@addonnetworks.com](mailto:salesemea@addonnetworks.com)

Telephone: +44 1285 842070