

Chapter 19.01 PURPOSE AND APPLICATION

Sections:

- 19.01.010 Purpose and background.**
- 19.01.020 How the design standards are applied.**
- 19.01.030 Interpretation.**
- 19.01.040 Design standards and guidelines applicability.**
- 19.01.050 Design standards and guidelines application requirements.**
- 19.01.060 General process for review of applications.**
- 19.01.070 Pre-application conference.**
- 19.01.080 Administrative review.**
- 19.01.090 Planning commission departures.**
- 19.01.100 Duration of approval.**

19.01.010 Purpose and background.

The preparation of design standards were authorized by the town council after obtaining a grant from the Washington State Department of Community, Trade and Economic Development for this purpose. The standards herein are refined from a set of guidelines drafted together with the Eatonville community action plan and vision statement. While the action plan and vision statement were adopted in 2000, the guidelines never were codified.

Refinements integrated in the standards herein were based on coordination with an advisory committee, town staff, and the project consultant, and ultimately reviewed by the planning commission and approved by the town council.

These design standards are an important tool in implementing the town's vision. In light of limited funding for publicly initiated projects and forecasts for growth, these standards will be critical in shaping growth via private development for years to come. Overall, the standards intend to:

- Provide clear objectives for those embarking on the planning and design of projects in Eatonville.
- To strengthen Eatonville's small town character and historic heritage.
- Increase awareness of design considerations among the citizens of Eatonville.
- To maintain and enhance property values within Eatonville.

Finding the Right Balance of Predictability and Flexibility

The standards herein have been formulated to find the right balance of predictability and flexibility while ultimately meeting the community's design objectives. Applicants, staff, and community members seek predictability for a variety of reasons. Predictability is critical for developers in determining financial feasibility of projects. Staff and applicants need clarity in understanding the difference between requirements and recommendations. Furthermore, both applicants and community members always would like to know what types of development could happen next door.

Flexibility is sought by applicants for obvious reasons. One example, a particular site may warrant consideration of alternative site layouts that are not allowed under the standards.

Perhaps they'd like to reduce one standard but compensate by providing more open space or another site amenity. Flexibility is often sought by staff as well when they believe that alternative designs might better achieve the community's objectives.

While these two attributes are often at odds in regulations, these standards have been crafted to provide the right balance of both predictability and flexibility. First of all, the standards use clear language to help users know the difference between requirements and recommendations. Second, the standards utilize a toolbox technique whereby applicants can choose amongst several options to meet the standard. The toolbox format also allows applicants a good way to control costs. Third, the standards provide for exceptions and departures (see EMC [19.01.020](#)) where alternatives can be used provided they meet the intent of the standards. Photo examples, illustrations, and design element descriptions are used to help users understand the requirements and criteria for alternatives. (Ord. 2010-09 § 1, 2010).

19.01.020 How the design standards are applied.

Each chapter contains a list of "intent" statements followed by "standards." Specifically:

- A. Intent statements are overarching objectives. For example, one of the intent statements for the subsection on building location and orientation is to "create an active and safe pedestrian environment."
- B. Standards using words such as "shall," "must," "is/are required," or "is/are prohibited" signify required actions.
- C. Standards using words such as "should" or "is/are recommended" signify voluntary measures.
- D. Exceptions are provided for some standards. These specific "exceptions" allow alternative designs subject to administrative approval by the planning director.
- E. Departures are similar to exceptions, but they require review and approval by the planning commission (see EMC [19.01.090](#) for details).

These design standards and guidelines contain both specific standards that are easily quantifiable, while the guidelines provide a level of discretion in compliance. With respect to the guidelines, the applicant must demonstrate to the planning director, in writing, how the project meets the guideline and the intent section. (Ord. 2010-09 § 1, 2010).

19.01.030 Interpretation.

These standards shall serve as a supplement to EMC Title [18](#) (Zoning). Where there is a conflict between the standards herein and EMC Title [18](#), the design standards herein shall apply as they are crafted more specifically to the site/use type. (Ord. 2010-09 § 1, 2010).

19.01.040 Design standards and guidelines applicability.

The design standards and guidelines apply to all proposals to subdivide land under the provisions of EMC Title [17](#), and to all new development including proposals to build, locate, construct, remodel, alter or modify any facade on any structure or building or other visible element of the facade of the structure or building or site, including, but not limited to, landscaping, parking lot layout, signs, outdoor furniture in public or commercial locations, outdoor lighting fixtures, fences, walls and roofing materials, all as described in this title.

Design approval is also required for all outdoor proposals which require a building permit, clearing and grading permit, or which are part of a project or development requiring a site plan, or conditional use permit. (Ord. 2010-09 § 1, 2010).

19.01.050 Design standards and guidelines application requirements.

A complete application for approval under the design standards and guidelines shall contain the following information:

A. Site Layout. A plan, drawn to scale no smaller than one inch equals 30 feet, showing the location and size of all structures, critical areas, required buffer areas, required yards, landscape areas, open spaces, common areas or plazas, walkways, retaining wall locations, stormwater retention facilities, and parking and vehicle maneuvering areas.

B. Significant Vegetation Plan. A significant vegetation plan which accurately identifies the species, size and location of all significant vegetation within the property subject to the application.

C. Tree Retention Plan. A landscape plan showing the species, size and location of all significant natural vegetation to be retained on the property.

D. Preliminary Site Section Drawings. Section drawings which illustrate existing and proposed grades.

E. Preliminary Grading Plan. A topographic map of the property, delineating contours, existing and proposed, at no greater than five-foot intervals. The plan shall indicate all proposed cuts, fills and retaining wall heights and include areas of disturbance necessary to construct all retaining walls, structures and impervious surfaces.

F. Preliminary Utilities Plan. A utilities plan showing the location and type of any utilities proposed in critical areas, critical area buffers and natural vegetation retention areas.

G. Paving Materials. A description of proposed pedestrian and vehicular paving materials, including proposed type (concrete, pavers, etc.), color, scoring and texture.

H. Elevation Drawings. Complete elevation drawings of all buildings showing dimensions and proposed materials including roofing, siding, windows and trim. Drawings shall include conceptual trim and cornice design, and roof pitch. If landscaping is proposed to soften or mitigate architectural modulation or details, additional elevation drawings showing proposed landscaping shall be provided.

I. Sign Plan. A sign plan showing the general location, type and size of signage on buildings.

J. Equipment Screening. A description of how all mechanical and utility equipment will be screened.

K. Color and Material Palette. A schematic color and material palette of the building's exterior siding, trim, cornice, windows and roofing. If planning commission review is requested (through the departure process), material and color samples shall be provided.

L. Fencing. The location and description of any proposed fencing.

M. Light Fixtures. A cutsheet showing typical parking and building lighting which includes pole height and mounting height. If proposed fixtures are near critical areas or natural vegetation retention areas, shielding shall be shown.

N. Accessories. The location of all outdoor furniture, trash receptacles and accessories.

O. Underlying Development Permit Application. If the design application relates to a development on the property, and development application (such as a building permit, conditional use permit, variance, preliminary plat, etc.) is required for the development, a complete application for the underlying development permit must be submitted concurrently.

P. Planning Commission Departures. A request for review for a departure by the planning commission shall include a written statement addressing the criteria for approval as set forth in EMC [19.01.090](#). (Ord. 2010-09 § 1, 2010).

19.01.060 General process for review of applications.

A. Administrative. All applications for approval under this title shall follow the administrative process set forth in EMC [19.01.080](#), if a departure is not requested.

B. Departures. All applications for approval under this title in which a departure is requested shall follow the planning commission meeting process set forth in EMC [19.01.090](#).

C. Timing of Submission of Applications. An application for approval under this title may not be submitted prior to the submission of the underlying permit application for a development on the same property (if an underlying permit is required for the development).

D. Vesting. A complete application for approval under this title does not vest to the land use controls in effect at the time the complete application is submitted. (Ord. 2010-09 § 1, 2010).

19.01.070 Pre-application conference.

All applicants may request an optional, pre-application conference before applying for any design or development permits. The goal of the meeting is to provide clear direction to the applicant early in the process regarding the application of the design standards and guidelines.

It also will provide an informal discussion of site-specific design issues and opportunities, and minimize the need for costly design changes late in the design phase. (Ord. 2010-09 § 1, 2010).

19.01.080 Administrative review.

All applications for approval under this title will be processed administratively, unless a departure is requested (and appropriate). The planning director (or his/her designee) shall process such applications as follows:

A. The planning director shall issue a notice of application (as required by EMC [18.09A.070](#)) for the application. After the application is determined complete under the procedures set forth in EMC [18.09A.060](#), the director shall determine whether the application conforms to the design standards and guidelines. The burden is on the applicant to demonstrate that the application conforms to the design standards and guidelines.

B. The director shall issue a decision on the application, approving the application if it conforms to the design standards and guidelines, and denying it if the application does not. If the application includes a

request for a departure, the director shall issue a recommendation on the application, and the planning commission shall issue a final decision.

C. The director shall issue a written decision or recommendation within 120 days of the town having issued the notice of complete application.

D. If the design application is stand-alone (does not relate to an underlying permit application for development on the same property), and does not include a request for a departure, the director's decision is final, and may be appealed to the town council. If the design application is stand-alone and includes a request for a departure, the director's recommendation is not appealable and the planning commission shall issue the final decision on the application, which may be appealed to the town council.

E. If the design decision relates to an underlying permit application for development on the same property, the director's decision shall be noted on the staff report for the underlying permit application. The hearing on the appeal shall be held during the hearing on the underlying permit application (if any appeal is required for such underlying permit application). The hearing body on such appeal shall be the body with jurisdiction over the underlying permit application. (Ord. 2010-09 § 1, 2010).

19.01.090 Planning commission departures.

An applicant may request a departure to the design standards and guidelines, as allowed in this title. The request must be submitted as part of the completed design application. The departure shall be processed as follows:

After the planning director issues a notice of application and determines whether the application is complete (see EMC [18.09A.060](#)), the planning director shall determine whether or not the request for a departure is appropriate. If the request is appropriate, he/she shall schedule a date for meeting on the application. This date shall be the earliest available planning commission meeting after the notice of application has been published.

A. The planning director shall issue his/her recommendation on the portion of the application that does not involve a departure, under the procedures set forth in EMC [19.01.080](#). The director's recommendation must issue at least five days prior to the planning commission's meeting on the departure and be included in the staff report.

B. The planning commission shall hold a public meeting on the departure and the planning director's recommendation.

1. If the design application is stand-alone (does not relate to an underlying permit application), the planning commission shall issue the final written decision on the application so that the final decision is issued within 120 days from the issuance of the notice of complete application. The planning commission may only amend or alter the planning director's decision if it would be inconsistent with the commission's decision on the departure. An appeal of the design decision may be filed with the town council.

2. If the design application is not stand-alone, the planning commission shall issue its decision at least five days prior to the open record public hearing on the underlying permit application. An appeal may be filed with the town council.

C. Criteria for Departure Approval. The planning commission may approve a design application with a departure, only if all of the following are satisfied:

1. The applicant must demonstrate that the criteria for approval as identified in this title as applicable to the specific departure are satisfied.

2. The departure proposed by the applicant represents an equivalent or superior design solution to what would otherwise be achieved by rigidly applying the design standards and guidelines.

3. Where an application does not relate to a preliminary plat, the planning commission shall not consider any deviation from any dimensional or numeric standards stated within the text of the design standards and guidelines, or zoning standards in EMC Title [18](#), unless an allowance for deviation to a dimensional or numeric standard is identified within the text of the code.

Approval to vary from these standards must otherwise be obtained through the variance process in EMC [18.09.040](#).

E. Planning Commission Meeting. The planning commission shall hold a public meeting on the design application as follows:

1. Notice.

a. Not less than 14 days prior to the meeting date, the planning director shall cause notice of the public meeting to be sent to property owners within 300 feet of the subject property and to others who have submitted comments and/or requested notice.

b. Notice of the public meeting shall be posted on the subject property not less than seven days prior to the meeting date.

c. Notice of the public meeting shall be published in the town's official newspaper not less than seven days prior to the meeting date.

d. The notice shall include the date of the meeting, the subject of the meeting, the property address, a map showing the location of the property, the applicant, a brief description of the application submitted to the town, and a statement informing the public that they may attend the meeting to provide input.

2. Applicant's Presentation. The applicant shall have an opportunity to make a presentation at the public meeting.

3. The staff shall have an opportunity to make a presentation at the public meeting.

4. The public shall be allowed to comment and provide input at the public meeting.

5. The planning commission shall deliberate on the application and presentations and comments, and shall make findings and conclusions on the application.

6. After the meeting, the staff shall draft the commission's findings and conclusions on the application, and present the same to the commission at their next regularly scheduled meeting for approval.

7. For all applications involving an underlying development permit, the commission's decision shall be presented to the hearing body on the underlying development permit with the staff report. The hearing body on the underlying development permit may make minor adjustments to the planning director's decision or the planning commission's decision if all of the following criteria are satisfied:

a. The minor adjustment does not substantially modify the decision of the planning director or planning commission;

b. The minor adjustment does not substantially modify the approved architecture, site layout, natural vegetation retention areas and grading; and

c. The minor adjustment represents a superior or equivalent design solution to what would otherwise be achieved by rigidly applying specific requirements; and

d. The minor adjustment meets the intent of the design standards and guidelines.

Notice of the decision on the minor adjustment shall be sent to all parties of record for the design decision and the decision on the underlying permit application. (Ord. 2018-14 § 2 (Exh. A), 2018; Ord. 2010-09 § 1, 2010).

19.01.100 Duration of approval.

Construction on projects that receive approval under this title must commence within 24 months from the date of final design approval, otherwise, the approval is null and void. (Ord. 2010-09 § 1, 2010).

**Chapter 19.02
DEFINITIONS**

Sections:

19.02.010 Applicability.

19.02.020 Definitions.

19.02.010 Applicability.

The definitions herein apply exclusively to the design standards herein. For words that are not defined, the planning director may use the definition set forth in EMC Title [18](#), where applicable. (Ord. 2010-09 § 1, 2010).

19.02.020 Definitions.

Defined words below are italicized throughout the title for user convenience.

A. Arcade: A series of arches supported on piers or columns.

B. Articulation: The giving of emphasis to architectural elements (like windows, *balconies*, entries, etc.) that create a complementary pattern or rhythm, dividing large buildings into smaller identifiable pieces.

C. Articulation Interval: The measure of articulation, the distance before architectural elements repeat.

D. Balcony: An outdoor space built as an above-ground platform projecting from the wall of a building and enclosed by a parapet or railing.

E. Bay Window: A window protruding from the main exterior wall. Typically, the bay contains a surface that lies parallel to the exterior wall and two surfaces that extend perpendicularly or diagonally out from the exterior wall. To qualify as a bay, the bay must contain a window pane that extends at least 60 percent of the length and 35 percent of the height of the surface of the bay lying parallel to the exterior wall. There need not be windows in the surfaces extending out from the exterior wall.

F. Blank Wall:

1. A ground floor wall or portion of a ground floor wall over six feet in height has a horizontal length greater than 15 feet and does not include a transparent window or door; or
2. Any portion of a ground floor wall having a surface area of 400 square feet or greater does not include a transparent window or door.

G. Cornice: A horizontal molding projecting along the top of a wall, building, etc.

H. Fenestration: The design, proportioning, and disposition of windows and other exterior openings of a building.

I. Low-Impact Development (LID): A term used to describe a land planning and engineering design approach to managing stormwater runoff that emphasizes conservation and use of on-site natural features to protect water quality.

J. Modulation: A stepping back or projecting forward of portions of a building face, within specified intervals of building width and depth, as a means of breaking up the apparent bulk of a structure's continuous exterior walls.

K. Pedestrian-Oriented Facade: Includes all of the following elements:

1. Primary building entrance must face the street and must be open to the public during all business operating hours. For street corner properties, entries shall be placed along both facades or directly at the street corner.
2. The facade must include transparent windows and/or doors along 75 percent of the ground floor at heights between two to eight feet above the ground. Glazed windows and doors that limit clear visibility into the building shall not count as "transparent." For sloping sites, the transparent windows must be positioned between three to eight feet above the ground on average.
3. The facade must include weather protection at least six feet wide along at least 75 percent of the facade.

L. Pedestrian-Oriented Space: Publicly accessible spaces that enliven the pedestrian environment by providing opportunities for outdoor dining, socializing, relaxing and provide visual amenities that can contribute to the unique character of the subarea. Design criteria for *pedestrian-oriented space*:

1. The following design elements are required for *pedestrian-oriented space*:

- a. All open spaces shall be physically and visually accessible from the adjacent street or major internal pedestrian route. Open spaces shall be in locations that the intended user(s) can easily access and use, rather than simply left-over or undevelopable space in locations where very little pedestrian traffic is anticipated.
- b. Paved walking surfaces of either concrete or approved unit paving (permeable paving encouraged).
- c. Pedestrian-scaled lighting (no more than 14 feet in height) at a level averaging at least two foot candles throughout the space. Lighting may be on-site or building-mounted lighting.
- d. At least three feet of seating area (bench, ledge, etc.) or one individual seat per 60 square feet of plaza area or open space. This provision may be relaxed or waived where there are provisions for movable seating that meet the intent of the standard as determined by the planning director.
- e. Spaces must be positioned in areas with significant pedestrian traffic to provide interest and security – such as adjacent to a building entry.
- f. Landscaping components that add seasonal interest to the space (LID techniques encouraged).

2. The following features are encouraged in *pedestrian-oriented space*:

- a. Pedestrian amenities such as a water feature, drinking fountain, and/or distinctive paving or artwork.
- b. Provide *pedestrian-oriented facades* on some or all buildings facing the space.
- c. Consideration of the sun angle at noon and the wind pattern in the design of the space.
- d. Transitional zones along building edges to allow for outdoor eating areas and a planted buffer.
- e. Movable seating.

3. The following features are prohibited within *pedestrian-oriented space*:

- a. Asphalt or gravel pavement, except where continuous gravel or asphalt paths intersect with the space.

- b. Adjacent chain link fences.
- c. Adjacent untreated *blank walls*.
- d. Adjacent unscreened dumpsters or service areas.

M. Rain Garden: A planted depression that allows rainwater runoff from impervious urban areas like roofs, driveways, walkways, and compacted lawn areas the opportunity to be absorbed.

N. Storefront: A *pedestrian-oriented facade* placed up to the edge of a public sidewalk.

O. Trellis: A frame supporting open latticework used as a screen or a support for growing vines or plants.

P. Turret: A small tower projecting from a building. (Ord. 2010-09 § 1, 2010).

Chapter 19.03 DESIGN STANDARDS FOR COMMERCIAL AND MULTIFAMILY ZONES

Sections:

19.03.010 Site planning.

19.03.020 Site design elements.

19.03.030 Building design.

19.03.010 Site planning.

The relationship of buildings, parking lots, and landscaping elements to the town's streets depends upon the type of street a site fronts onto. Eatonville's commercial and multifamily zones feature a hierarchy of four different types of streets – illustrated in Figure 1 below.

Storefront streets, which are intended to be lined with *storefronts*; mixed-use streets, which are intended to allow for *storefronts* or a combination of retail, office, civic, and/or residential uses with a landscaped setback; gateway street, which refers to Center Street E and is unique enough to deserve its own set of standards; and landscaped streets (not highlighted in Figure 1), which refers to streets where landscaped setbacks are required.

Designations for new streets in applicable zones shall be made by the town and designated on the plat or other applicable plans. The standards in this chapter (and in other chapters) thus refer to these particular types of streets.

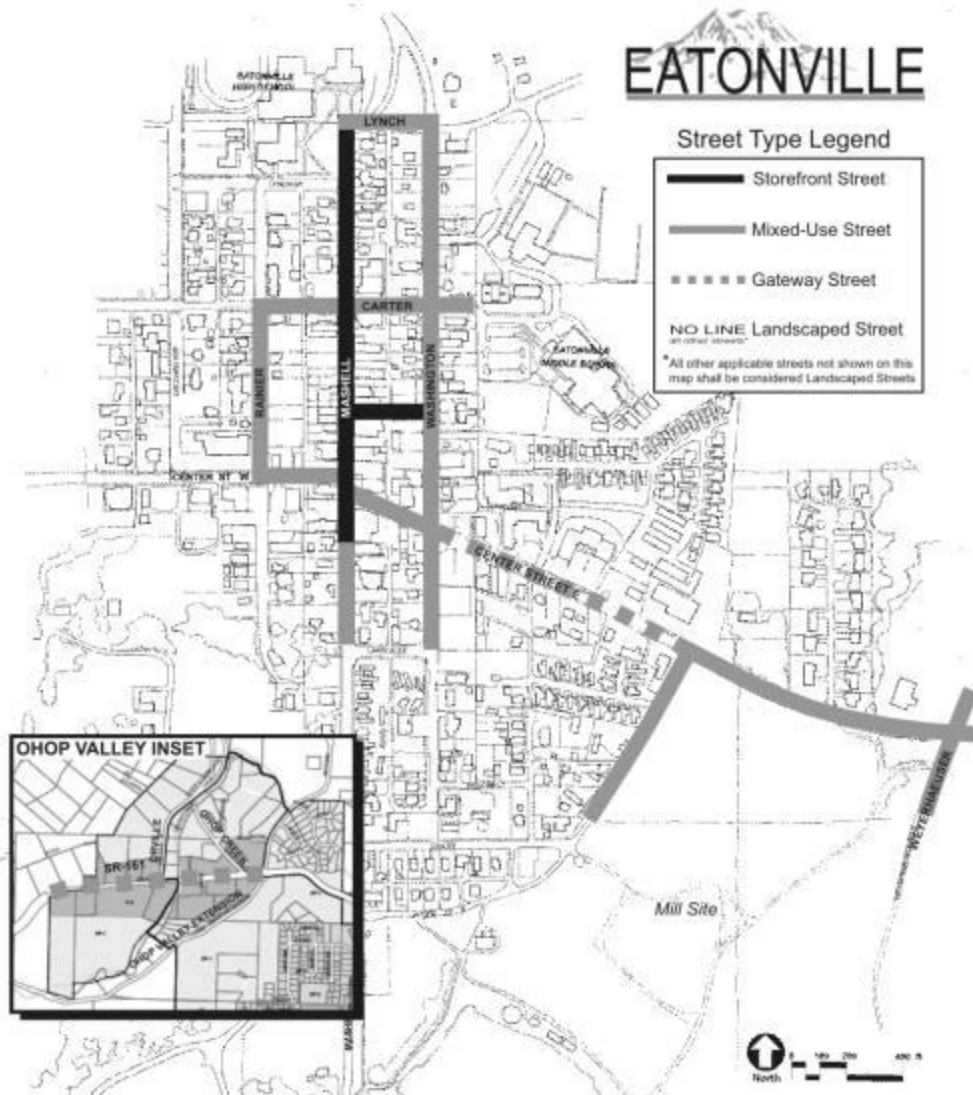

Figure 1. Map of street types for the purpose of determining street frontage and site layout standards in commercial and multifamily zones.

A. Street Frontages and Site Layout.

1. Intent.

- a. To create an active and safe pedestrian environment by encouraging development to orient towards the street.
- b. To strengthen and reinforce the pedestrian-oriented character of Eatonville's downtown, neighborhoods, and corridors.
- c. To enhance the visual character of Eatonville's streets.

2. *Storefront* Streets. (See Figure 1 for applicable streets.)

a. Building location and design. Buildings must be located adjacent to the sidewalk and feature a *pedestrian-oriented facade* (see Figure 2). Such facades must include:

i. Primary building entrance must face the street and must be open to the public during all business operating hours. For street corner properties, entries shall be placed along both facades or directly at the street corner.

ii. The facade must include transparent windows and/or doors along 75 percent of the ground floor at heights between two to eight feet above the ground. Glazed windows and doors that limit clear visibility into the building shall not count as “transparent.” For sloping sites, the transparent windows must be positioned between three to eight feet above the ground on average.

iii. The facade must include weather protection at least six feet wide along at least 75 percent of the facade.

Exception: Buildings may be set back from the sidewalk where *pedestrian-oriented space* is included between the sidewalk and the building.

DEPARTURES: Public and institutional (e.g., churches, hospitals) buildings and buildings housing permitted assembly uses are eligible for departures to the items in subsections (A)(2)(ii) and (iii) of this section provided the design treatment meets the intent of the standards.

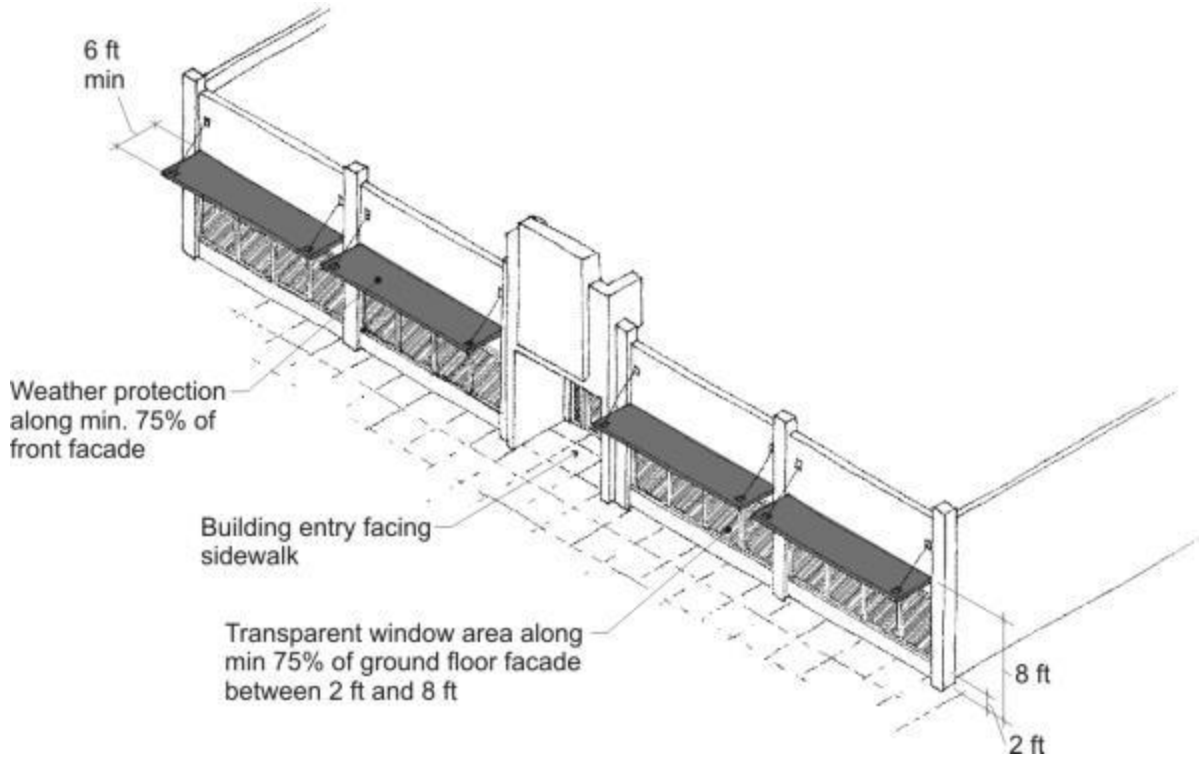

Figure 2. Pedestrian-oriented facade requirements.

b. Parking Lot Location. Parking lots must be located behind buildings and away from *storefront* streets. New parking lots adjacent to a pedestrian-oriented street are prohibited.

DEPARTURES may be considered by the town provided the development configuration and treatment to screen the parking lot meets the intent of the standards. In all such departures, no more than 60 feet of frontage may be occupied by parking and design features must be included to define the street edge along the sidewalk. An example includes a low wall or planter with a landscaped *trellis* on top. Such features shall be designed to provide eye level views into the parking lot (generally from heights between three and eight feet above grade).

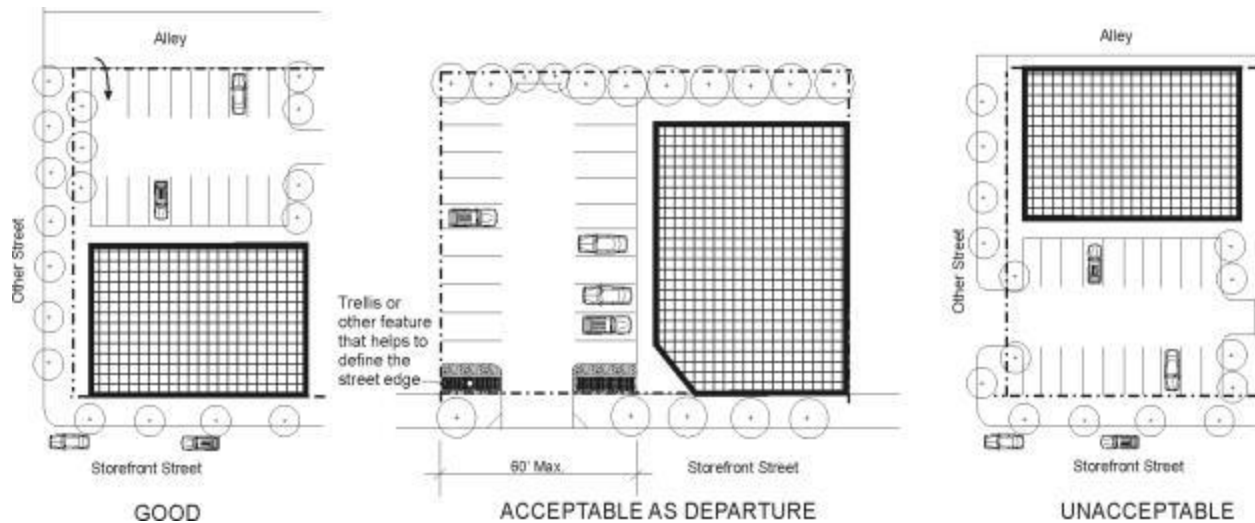

Figure 3. Parking location standards.

c. Structured Parking. Structured parking facilities shall be located below, above, or behind *storefronts*. Structures incorporating above-ground parking facilities must comply with building design standards in EMC [19.03.030](#).

3. Mixed-Use Streets. (See Figure 1 for applicable streets.)

a. Buildings featuring non-residential uses on the ground floor may be placed up to the edge of the sidewalk (unless otherwise noted) only if they feature a *pedestrian-oriented facade*, as defined.

b. All other developments must feature at least 10 feet of landscaping or *pedestrian-oriented space* between the sidewalk or front property line and any building, parking area, storage, or service area.

Landscaping between the sidewalk and any parking area shall include:

i. Trees, as approved by the planning director, shall be planted at a rate of one tree per 300 square feet of landscaped area. Choose tree, location, and trimming method to maximize visibility between windows and the street for safety.

ii. Shrubs at a rate of one shrub per 20 square feet of landscaped area. Shrubs shall be at least 16 inches tall at planting and have a mature height between three and four feet.

iii. Ground cover shall be planted in sufficient quantities to provide 100 percent coverage of the landscaped area within three years of installation.

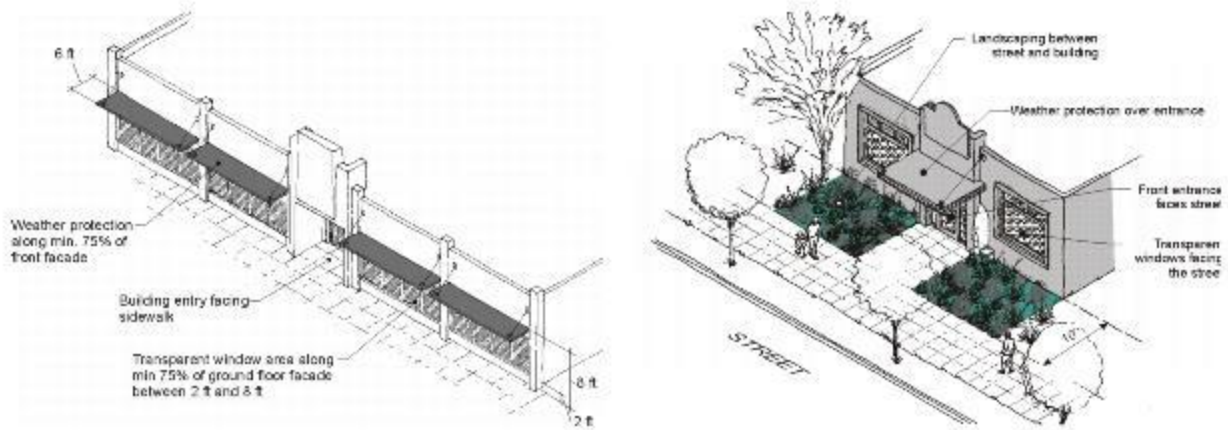

Figure 4. Development fronting on mixed-use streets may feature either a pedestrian-oriented facade or a landscaped setback.

DEPARTURES: Reduced width planting strips and/or alternative landscaping designs will be considered by the town where the applicant can successfully demonstrate that the streetfront design creates an attractive, safe, and comfortable pedestrian environment that is consistent with the goals and objectives of the downtown plan. Such proposals must include design elements that clearly go beyond minimum requirements. For example, proposals for a reduced width planting area could include terraced planting beds along the sidewalk, extensive transparent window/door areas facing the sidewalk, and/or special building detailing that adds special interest at a pedestrian scale. For reduced setbacks for residential uses, the town may require that the ground floor be elevated at least three feet above the level of the sidewalk to increase privacy for the streetfront residential units.

c. Building Entrances. Buildings must feature pedestrian entrances that face the streets (see Figure 4).

Exceptions: Buildings organized around a courtyard may feature entrances facing the courtyard provided there is clear pedestrian access between the courtyard and the street.

d. Facade Transparency. Transparent windows and/or doors shall cover at least 25 percent of the ground floor facade of non-residential uses between four and eight feet above the sidewalk. For residential facades, this transparency requirement shall be 15 percent for the entire facade (all vertical surfaces facing the street).

DEPARTURE: Reduced transparency proposals will be considered by the town provided alternative design treatments maintain some visibility between the inside of the building and

the street. Example treatments (in addition to transparent window areas) could include, but are not limited to, a vertical *trellis* with vine plants, a mural, a series of terraced planting beds between the facade and the sidewalk, or distinctive building details that provide interest at a pedestrian scale. A *blank wall* with no windows and a simple evergreen planting screen will not be enough to meet the intent of the standards.

e. Parking Lot Location. Parking lots must be located to the side or rear of buildings and may not be located adjacent to intersections. For multi-building developments, no more than 50 percent of the street frontage may be occupied by parking lots and vehicle access areas.

DEPARTURE: The town may grant flexibility to the 50 percent requirement for one street frontage where a property fronts on more than one mixed-use street or corridor and there are no other reasonable alternatives.

Depending on width and visibility of frontage, additional design features may be required to mitigate impacts of parking lots on the pedestrian environment and define the street edge. Examples could include a *trellis* system with vines and/or a decorative low wall that incorporates landscaping. Such treatments shall maintain adequate eye level visibility into the site from the street for safety.



Figure 5. Parking location standards for properties fronting mixed-use streets.

f. Structured parking configurations should locate parking areas below, above, or behind uses. Structures incorporating above-ground parking facilities must comply with building design standards in EMC [19.03.030](#).

4. Gateway Streets. (See Figure 1 for applicable streets.)

a. Landscaping Along Sidewalk. All new developments and Level III remodels shall provide a planting strip between the sidewalk and any building, parking lot, service, or storage area. The minimum width of planting strips shall be 10 feet adjacent to applicable portions of Center Street and 25 feet adjacent to SR-161 along commercially zoned sites in Ohop Valley. The planting strip shall meet the landscaping standards specified in Figure 6 below. Trees and shrubs shall be maintained to maximize eye and car-level views into the site (shrubs at a maximum of three feet in height and trees limbed up to eight feet or higher if possible) for safety and business visibility.

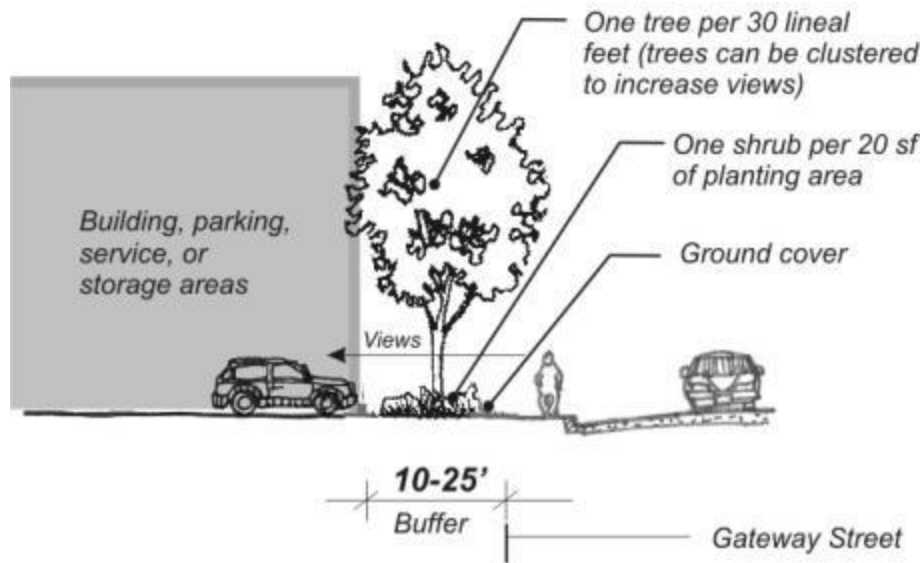

Figure 6. Landscaping standards for planting strips along gateway streets.

b. Building Location. Buildings are encouraged to be located towards the street and adjacent to the front planting strip required above. However, buildings placed in other locations are acceptable provided they meet pedestrian access and transparency requirements herein.

c. Pedestrian Access. All buildings must have clear pedestrian access between the sidewalk and all buildings. Such access routes through parking areas shall be separated from vehicular parking and travel lanes by use of contrasting paving material which may be raised above the vehicular pavement. Speed bumps may not be used to satisfy this requirement.

d. Facade Transparency. Transparent windows and/or doors shall cover at least 25 percent of the ground floor facade of non-residential uses between four and eight feet above the

sidewalk. For residential facades, this transparency requirement shall be 15 percent for the entire facade (all vertical surfaces facing the street).

DEPARTURE: Reduced transparency proposals will be considered by the town provided alternative design treatments maintain some visibility between the inside of the building and the street. Example treatments (in addition to transparent window areas) could include, but are not limited to, a vertical *trellis* with vine plants, a mural, a series of terraced planting beds between the facade and the sidewalk, or distinctive building details that provide interest at a pedestrian scale. A *blank wall* with no windows and a simple evergreen planting screen will not be enough to meet the intent of the standards.

5. Landscaped Streets. (See Figure 1 for applicable streets.)

a. Landscaping Along Sidewalk. Landscaped setbacks at least 10 feet in width are required between the back of the sidewalk and any building or parking area. Landscaping between the sidewalk and any parking area shall include:

i. Trees, as approved by the planning director, shall be planted at a rate of one tree per 400 square feet of landscaped area.

ii. Shrubs at a rate of one shrub per 20 square feet of landscaped area. Shrubs shall be at least 16 inches tall at planting and have a mature height between two and four feet. Lawn area may be used in place of up to 50 percent of the shrubs.

iii. Ground cover shall be planted in sufficient quantities to provide 100 percent coverage of the landscaped area within two years of installation.

Landscaping (plant types and maintenance) between the sidewalk and residential units shall maintain visual access between the dwelling units and the street.



Figure 7. Desirable building configuration along a landscaped street.

DEPARTURES: Reduced width planting strips and/or alternative landscaping designs will be considered by the town where the applicant can successfully demonstrate that the streetfront design creates an attractive, safe, and comfortable pedestrian environment. Such proposals must include design elements that clearly go beyond minimum requirements. For example, proposals for a reduced width planting area could include terraced planting beds along the sidewalk, extensive transparent window/door areas facing the sidewalk, and/or special building detailing that adds special interest at a pedestrian scale. For reduced setbacks for residential uses, the town may require that the ground floor be elevated at least three feet above the level of the sidewalk to increase privacy for the streetfront residential units.

b. Parking Location. Parking lots shall be located to the side or rear of buildings. Parking lots may not be located adjacent to street corners.

c. Building Entries. All buildings must provide entries facing the street. For example, townhouses fronting on the street must all have individual entries accessible from the street. Buildings organized around a courtyard may feature entrances facing the courtyard provided there is clear pedestrian access between the courtyard and the street. Configurations where enclosed rear yards back up the street are prohibited.

d. Facade Transparency. At least 15 percent of the building facades (for all uses) must be transparent. All vertical surfaces facing the street shall be considered part of the facade. Openings in parking garages may not be used to meet this requirement, except when designed with *fenestration* and detailing techniques that make the garage appear to be a habitable part of the structure.



Figure 8. Development examples along a landscaped street.

B. Side and Rear Yard Design.

1. Intent.

- a. To provide for compatibility between developments.
- b. To provide side and rear yard design options that enhance the area's pedestrian environment and the setting for development.

2. Side/Rear Yard Design Options. Project applicants shall incorporate one or more of the following design options into the site's design:

- a. Provide a zero-lot line fire wall for commercial or mixed-use developments fronting on *storefront* or mixed-use streets. This configuration provides for the maximum use of property. Developments are encouraged to consider the design implications to the adjacent property.
- b. Provide a shared internal drive or public street/alley along the property line. This configuration may be required by the town for large sites where there is a strong need for internal connectivity. Depending on the status of the adjacent property, this may be partial roadway along the property line or a complete roadway entirely within the subject property. This determination will be made by the planning director. Where the roadway is constructed entirely within the subject property, at least five feet of Type I, II or III landscaping shall be provided between the road and the property line.
- c. Provide a trail or other internal pathway along the property line. Trails that span the property line require written approval from the adjacent property owner. Other trails require at least five feet of Type I, II or III landscaping between the trail and the property line.
- d. Retain existing native or desirable mature vegetation along the side or back property line.
- e. Provide a six-foot-tall wood or masonry fence and/or at least five feet of Type I or II landscaping along the side and/or rear property line(s). These options may be used only where options in subsection (B)(2)(a), (b), (c) or (d) of this section are not viable as determined by the planning director.
- f. A *rain garden* or other *low-impact development* measure may be incorporated as part of the treatments above.

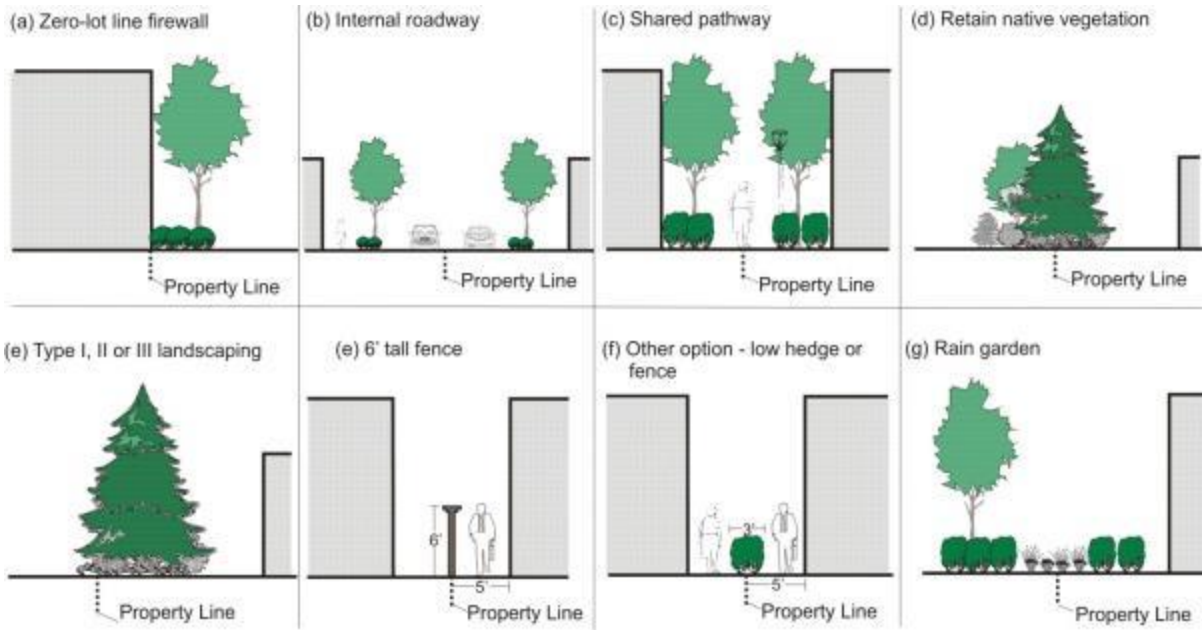

Figure 9. Side and rear yard design treatment options.

3. Solar Access and Privacy Along Side/Rear Yards.

- a. Buildings or portions thereof containing multifamily dwelling units whose solar access is only from the applicable side of the building (facing towards the side property line) shall be set back from the applicable side or rear property lines at least 15 feet. See Figure 11.
- b. *Balconies* or rooftop decks within 15 horizontal feet of a side property line must utilize opaque guard rails to minimize privacy impacts to adjacent properties.

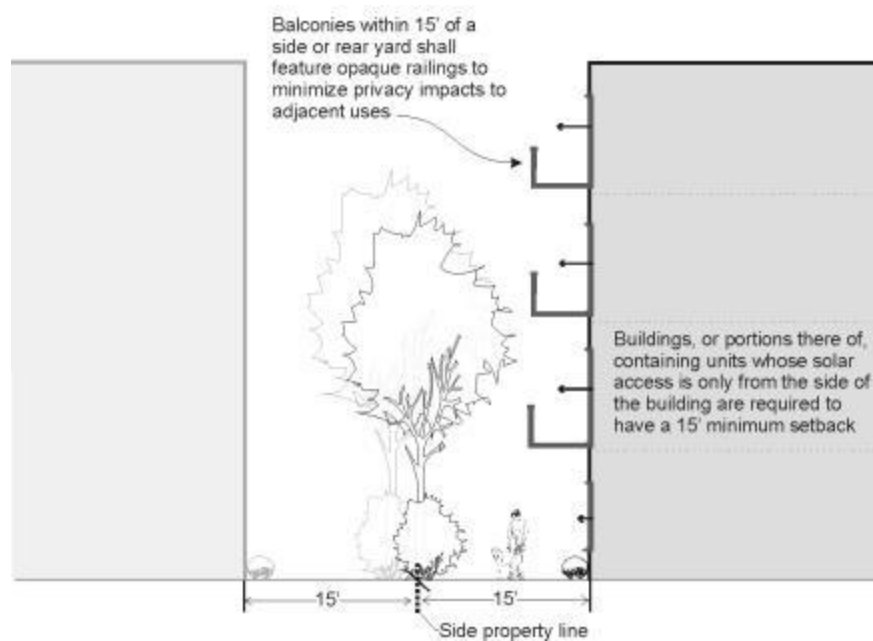

Figure 10. Solar access and privacy standards for multifamily residential buildings along side/rear yards.

C. Multiple Building/Large Lot Development.

1. Intent.

- a. To reduce impacts on adjacent uses.
- b. To take advantage of special opportunities to create a composition of buildings and landscaped features.
- c. To enhance pedestrian and vehicular circulation.
- d. To enhance the visual character of the community.

2. Large Site Design Criteria. All development permit applications for sites over two acres or with multiple buildings must demonstrate how the project meets all of the following criteria:

- a. Incorporates open space and landscaping as a unifying element. For example, the site plan in Figure 11 shows a focal point open space with connecting pathways, and consistent landscaping elements. The use of consistent palette of attractive landscaping materials will help to unify the development.

b. Incorporate screening, utilities, and drainage as positive design elements of the site (example: create a “natural” open space or wet pond as a site feature to accommodate surface water runoff).

c. Provides pedestrian paths or walkways connecting all businesses and the entries of multiple buildings. Again, see Figure 11 as a good example.

d. Incorporates *low-impact development* stormwater management systems as part of the site plan. Participating in a multi-property stormwater facility or system will also satisfy this requirement.

e. Building entrances must not be focused around a central parking lot but be connected by a sidewalk/pathway system and/or open space(s). Again, see Figure 11 as a good site layout example.

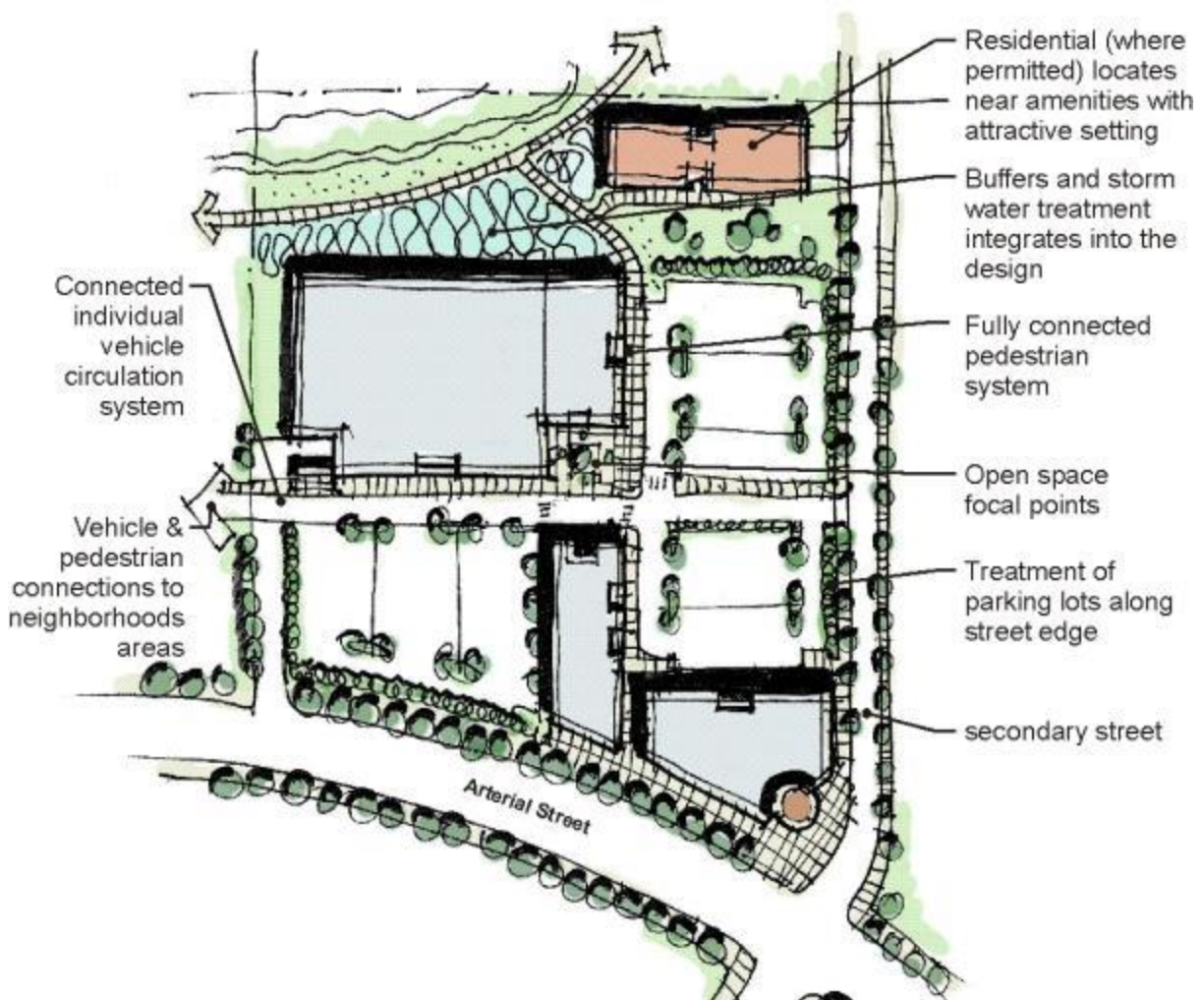

Figure 11. Illustrating large site development design criteria.

3. Mill Site Design Criteria. In addition to the design criteria set forth in subsection (C)(2) of this section, development proposals on the former mill site shall demonstrate how the proposal meets the following criteria:

- a. The natural areas adjacent to the Mashell River shall be preserved and utilized as a major site amenity. Native vegetation along the river's edges shall be retained in a natural state.
- b. Incorporates features of the historic mill (per historical records/photos) into the architecture and site design of the development.

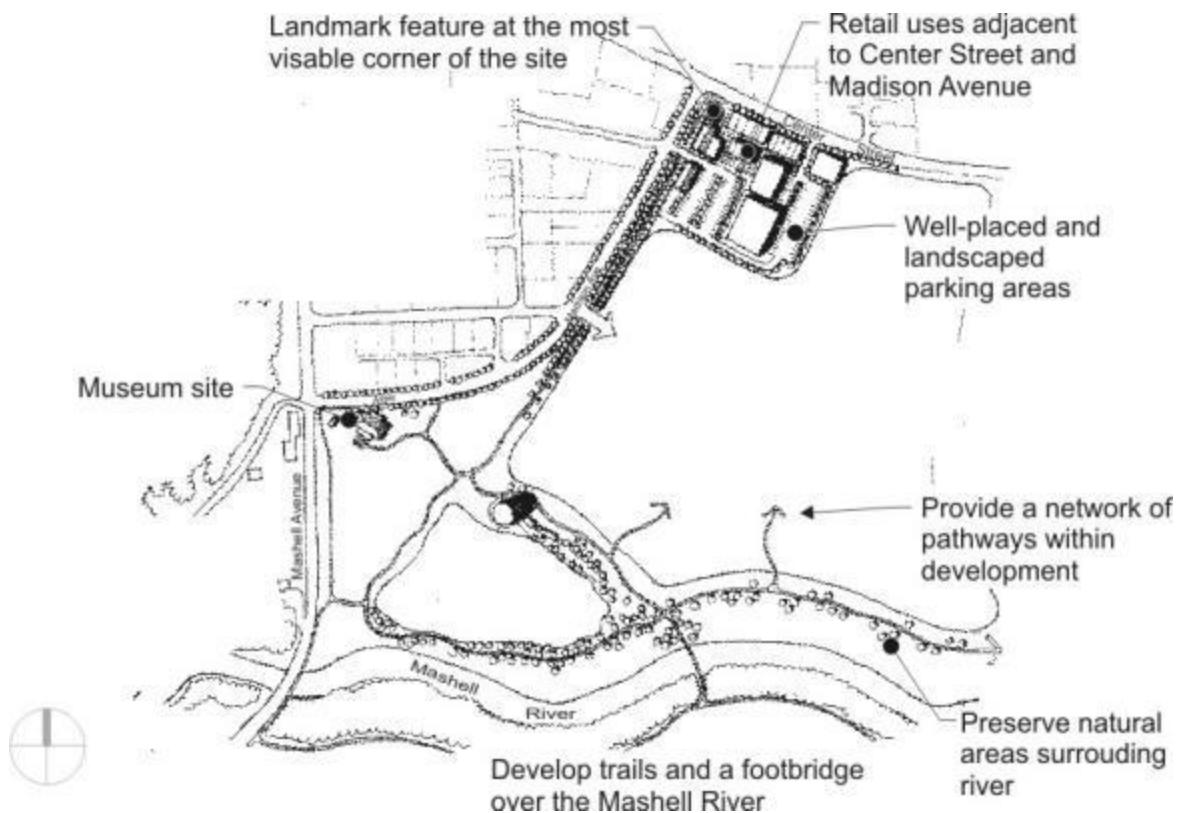

Figure 12. Key mill-site development features.

- c. A decorative entry feature shall be developed at the Center Street/Madison Avenue intersection. This feature is intended to announce the site and welcome visitors. Physical and visual access into the site is strongly encouraged. The illustration in Figure 13 provides an example as to how this can be accomplished.

d. A network of on-site pathways shall be provided throughout the development, connecting all uses on the site. Specifically:

- i. Develop a trail along the north side of the Mashell River.
- ii. Provide pedestrian connections that lead to these and other trails.

Depending on the nature of the site and adjacent uses, the type of pathway can range from a wide paved multi-purpose pathway to a nature trail.

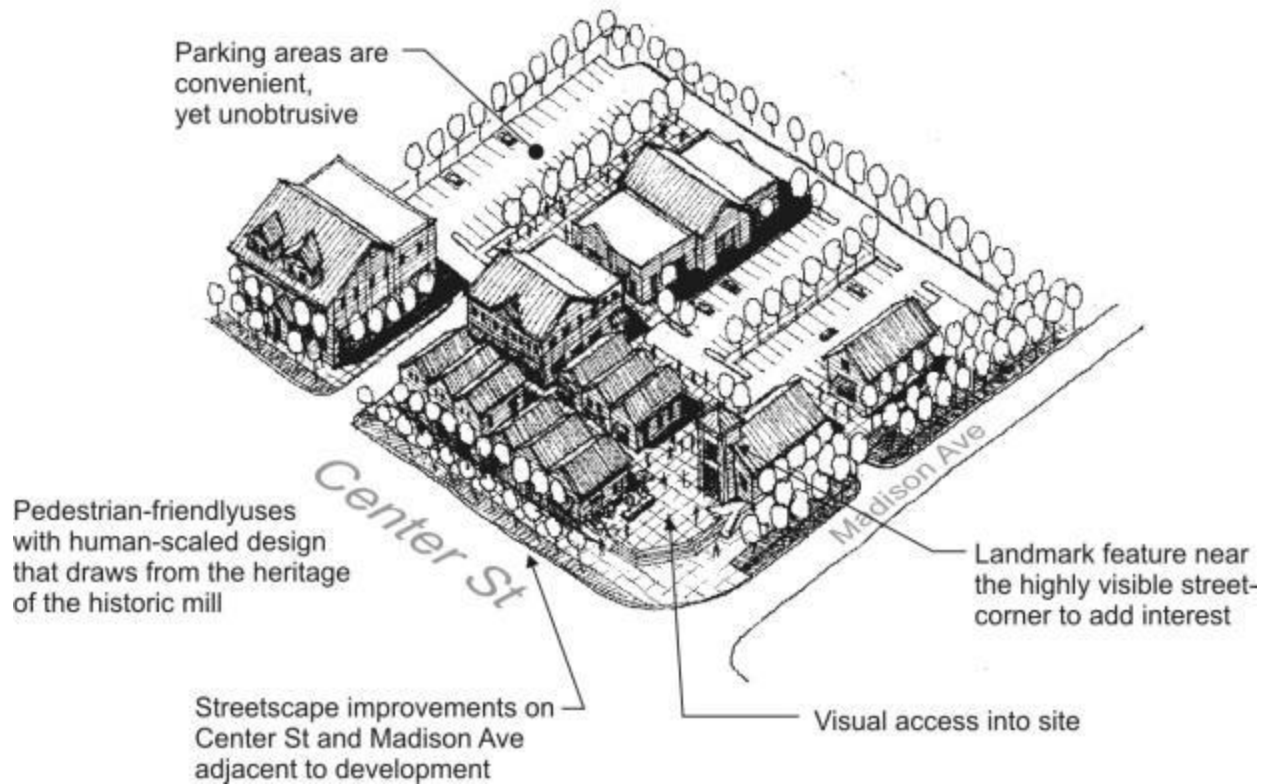

Figure 13. A desirable development example for the northwest corner of the mill site.

D. Internal Vehicular Circulation and Driveways.

1. Intent.

- a. To provide safe, convenient access to commercial sites without diminishing quality pedestrian walking or visual experiences.
- b. To enhance the safety and function of public streets.

2. Internal Vehicular Circulation. Developments shall provide a safe and convenient network of vehicular circulation that connects to the surrounding road/access network and should provide the opportunities for future connections to adjacent parcels. For example, large sites (at least two acres) should generally utilize a network of vehicular connections at intervals of no more than every 400 feet. This is on a scale similar to most pedestrian-oriented downtowns.

3. Driveway Standards.

a. Projects adjacent to SR-161 shall comply with the state's access management regulations.

b. Limit Number of Driveways. Parking lot entrances, driveways, and other vehicle access routes onto private property from a street shall be restricted to no more than one entrance lane and one exit lane per 300 linear feet of property as measured horizontally along the street face.

c. Encourage Shared Driveways. Properties with less than 300 linear feet of street frontage should make a genuine effort to negotiate shared access with adjoining property owners.

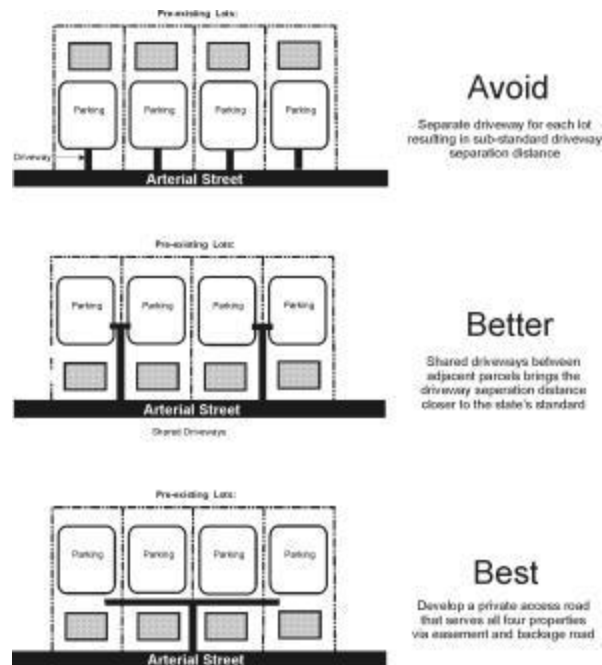

Figure 14. Encourage shared driveways.

d. Driveways for Corner Lots. Vehicular access to corner lots shall be located on the lowest classified roadway and as close as practical to the property line most distant from the intersection.

Exception: Corner lots may have one entrance per street provided the owner provides evidence acceptable to the planning director that they are unable to arrange joint access with an abutting property.

4. Parking Garage Entrances. Parking garage entries (both individual private and shared parking garages) must not dominate the streetscape. They should be designed and sited to complement, not subordinate, the pedestrian entry. This applies to both public garages and any individual private garages, whether they front on a street or private interior access road. Specific standards and guidelines:

a. Townhouse developments featuring two-car garages facing a public or private drive (where the primary pedestrian entry is off the same drive) are required to employ tandem garages on at least 50 percent of the units to minimize the garage's negative visual impact on the street and visual environment. Garages facing alleys are exempt from this standard.

b. Townhomes and all other multifamily dwelling units with private exterior ground floor entries must provide at least 20 square feet of landscaping adjacent to the entry. This is particularly important for units where the primary entrance is next to private garages off of an interior access road. Such landscaping areas soften the appearance of the building and highlight individual entries.





Figure 15. Acceptable (top) and unacceptable (bottom) townhouse parking garage entrance examples.

E. High Visibility Street Corners. In small gateway towns such as Eatonville, street corners are particularly important as they represent the most visible sites in town. The design of these corner sites and buildings sited on them warrant special design consideration.

1. Intent.

- a. To enhance the character and identity of Eatonville.
- b. To accentuate highly visible street corners.

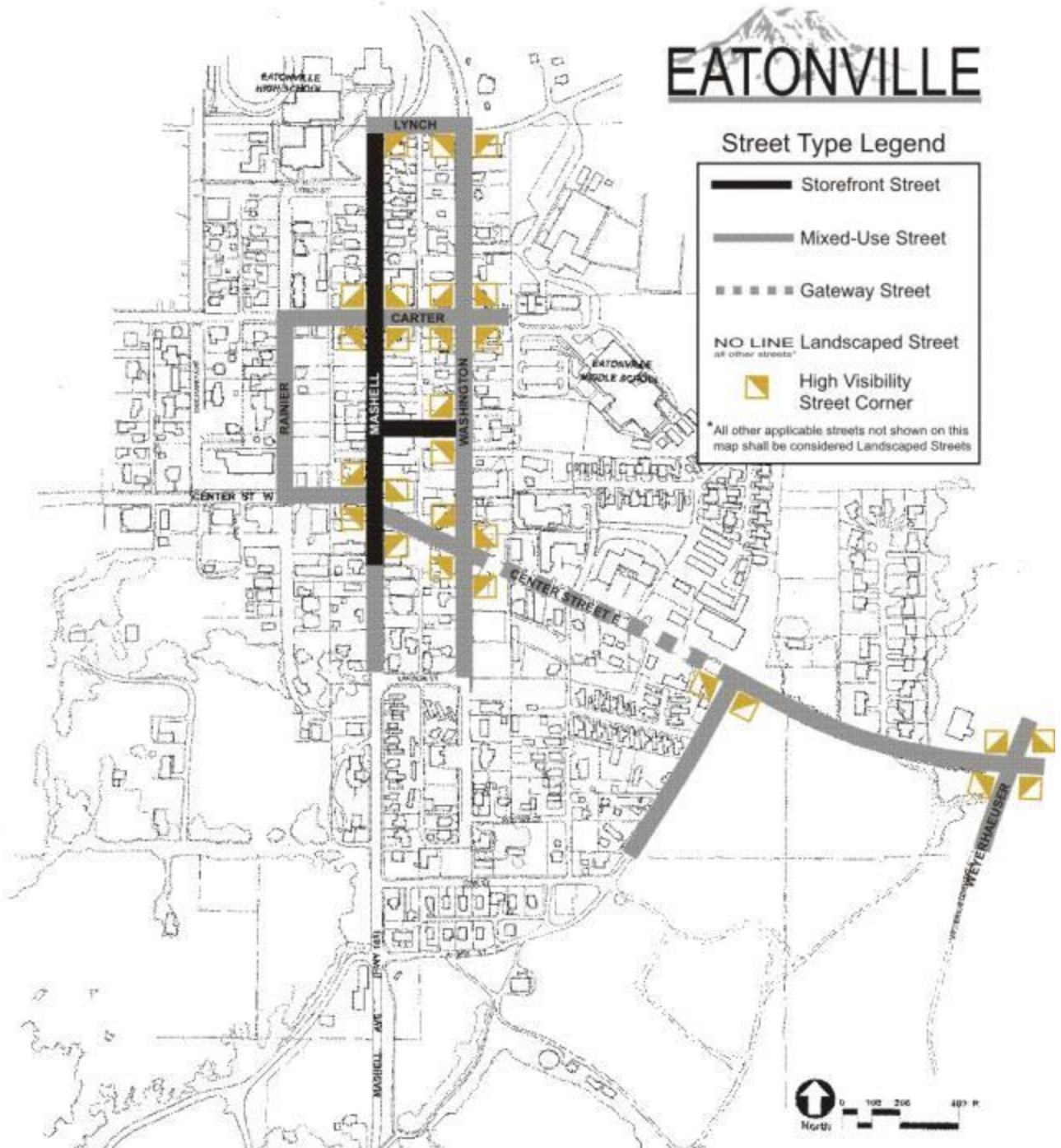

Figure 16. Map of designated high visibility street corners.

2. Design Options. All development proposals located at designated high visibility street corner (see Figure 16 on the previous page) sites shall include at least one of the design treatments described below (in order of preference):

- a. Locate a building towards the street corner (within 15 feet of the corner property line). All such buildings shall comply with building corner standards in EMC [19.03.030](#).
- b. Provide *pedestrian-oriented space* at the corner leading directly to a building entry or entries.
- c. Install substantial landscaping (at least 30 feet by 30 feet or 900 square feet of ground surface area with trees, shrubs, and or ground cover). In addition to the landscaping, the space shall include a special architectural element, such as a *trellis*, decorative monument sign, or clock-tower, to add identity or demarcation of the area. Such an architectural element may have a sign incorporated into it (as long as such sign does not identify an individual business or businesses).

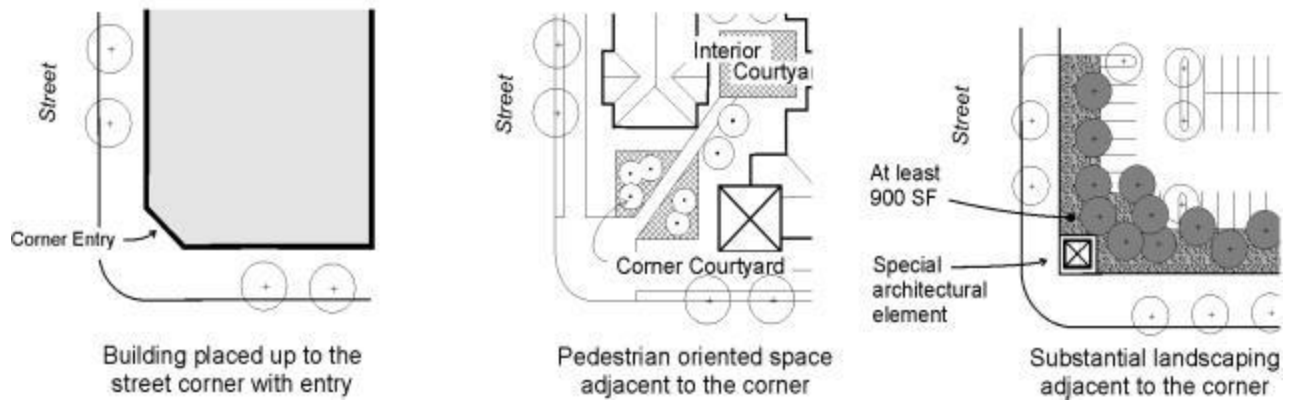

Figure 17. Acceptable street corner examples.

(Ord. 2010-09 § 1, 2010).

19.03.020 Site design elements.

This section addresses standards for site design elements such as sidewalks, internal pathways, pedestrian amenities, on-site open space, service element location and design, and lighting.

A. Sidewalks and Pedestrian Circulation.

1. Intent. To improve the pedestrian environment by making it easier, safer, and more comfortable to walk to and between businesses, along streets, and through parking lots.
2. Sidewalk Design. Developments shall utilize appropriate sidewalk widths, materials, designs, and construction standards and guidelines to enhance pedestrian access and complement town life. Specifically:

a. Sidewalks shall be constructed per the town's engineering design and development standards (EDDS), unless otherwise directed by these design standards and guidelines.

b. Sidewalk standards by street:

Table 1. Basic Sidewalk Types Defined

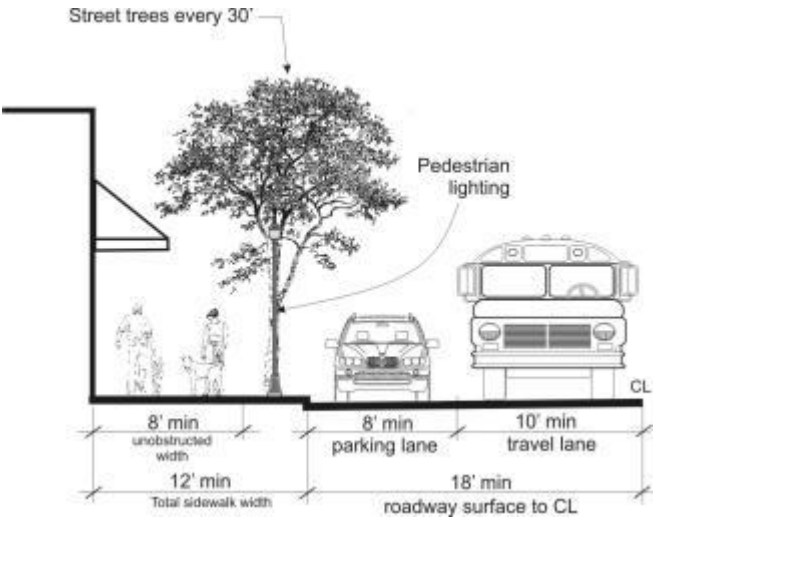
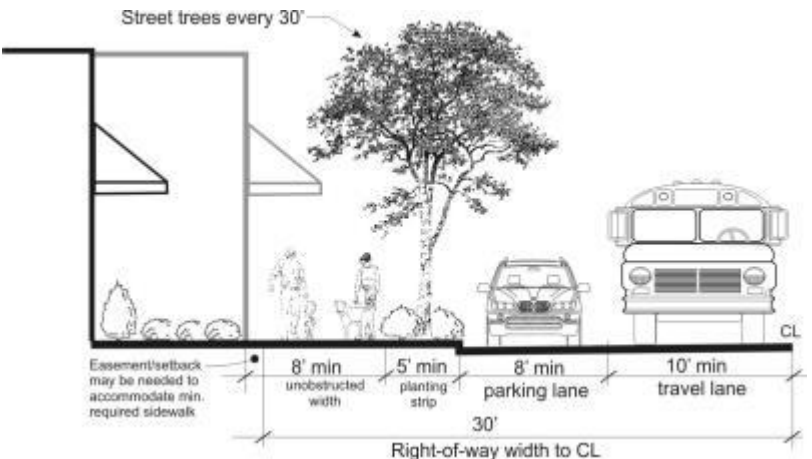
<p>Storefront Street Standards. (See Figure 1 for applicable streets.)</p> <p>12' min. sidewalks with trees every 30' in grates and 8' min. unobstructed sidewalk width (<i>Exception: No trees on Mashell from Center to Carter</i>)</p> <ul style="list-style-type: none"> • wider sidewalks encouraged to provide outdoor seating area and/or outdoor display area 	 <p>The diagram illustrates the Storefront Street Standards. It shows a cross-section of a street with a sidewalk on the left and a roadway on the right. A tree is planted in the sidewalk area, with a note indicating 'Street trees every 30\''. Pedestrian lighting is shown above the sidewalk. The sidewalk has a total width of 12' min, with an unobstructed width of 8' min. The roadway has a total width of 18' min to the centerline (CL), consisting of an 8' min parking lane and a 10' min travel lane. A car and a bus are shown in the roadway lanes.</p>
<p>Mixed-Use Street Standards. (See Figure 1 for applicable streets.)</p> <p>8' min. sidewalks with 5' min. planting strips trees every 30'</p> <p>Wider sidewalks encouraged to provide outdoor seating area and/or outdoor display area</p> <ul style="list-style-type: none"> • outdoor display area 	 <p>The diagram illustrates the Mixed-Use Street Standards. It shows a cross-section of a street with a sidewalk on the left and a roadway on the right. A tree is planted in a 5' min planting strip between the sidewalk and the roadway. The sidewalk has an unobstructed width of 8' min. The roadway has a total width of 30' to the centerline (CL), consisting of an 8' min parking lane and a 10' min travel lane. A car and a bus are shown in the roadway lanes. A note indicates that an 'Easement/setback may be needed to accommodate min. required sidewalk'.</p>

Center Street E and Ohop Valley Street Standards.

- 8' min. sidewalks with 5' min.
- planting strips trees every 30'
- Wider sidewalks encouraged to provide outdoor seating area and/or
- outdoor display area

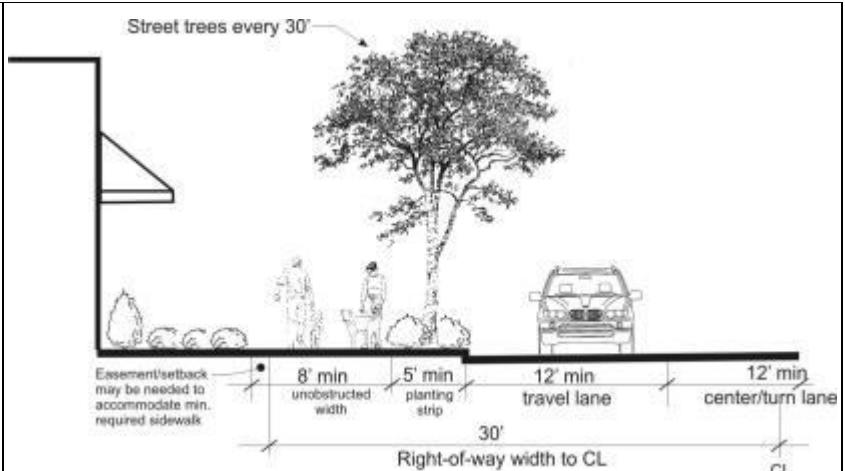

Landscaped Street Standards.
(See Figure 1 for applicable streets.)

- 5' min. sidewalks with 5' min.
- planting strips trees every 30'
- Wider sidewalks encouraged to provide outdoor seating area and/or
- outdoor display area

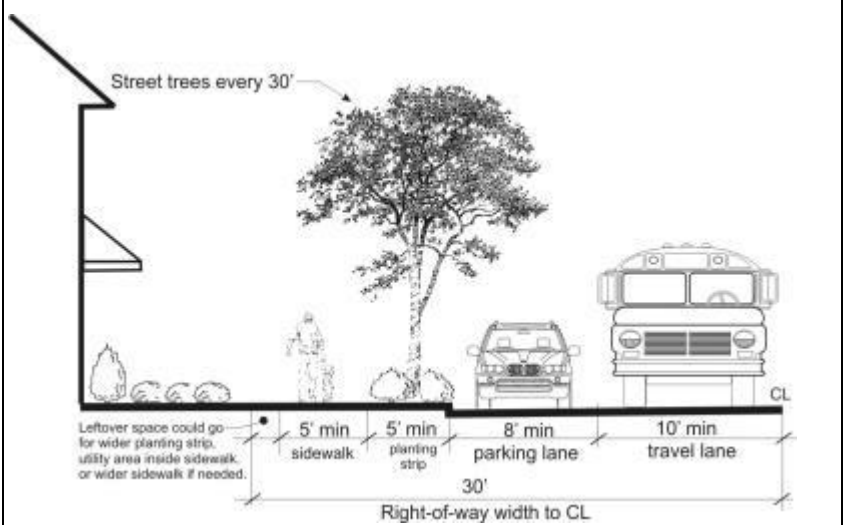

c. No business activities are allowed in the minimum required sidewalk width.

3. Internal Pedestrian Circulation.

a. All buildings shall have clear pedestrian access to the sidewalk. Where a use fronts two streets, access shall be provided from the road closest to the main entrance, preferably from both streets. Buildings with entries not facing the street should have a clear and obvious pedestrian access way from the street to the entry.

b. Pedestrian paths or walkways connecting all businesses and the entries of multiple commercial buildings frequented by the public on the same development site shall be

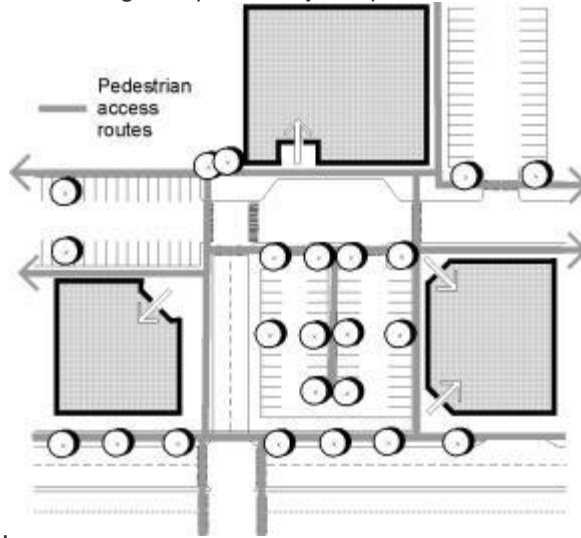

provided.

Figure 18. Good internal pedestrian circulation. Note connections from the street, between buildings and through parking lots.

c. Parking Lot Pathways. A paved walkway or sidewalk shall be provided for safe walking areas through parking lots greater than 150 feet long (measured either parallel or perpendicular to the street front). Walkways shall be provided for every three parking aisles or a distance of less than 150 feet shall be maintained between paths (whichever is more restrictive). Such access routes through parking areas shall be separated from vehicular parking and travel lanes by use of contrasting paving material, which may be raised above the vehicular pavement. Speed bumps may not be used to satisfy this requirement. Trees and pedestrian-scaled lighting (maximum 15 feet in height) shall be used to clearly define pedestrian walkways or other pedestrian areas within the parking area.

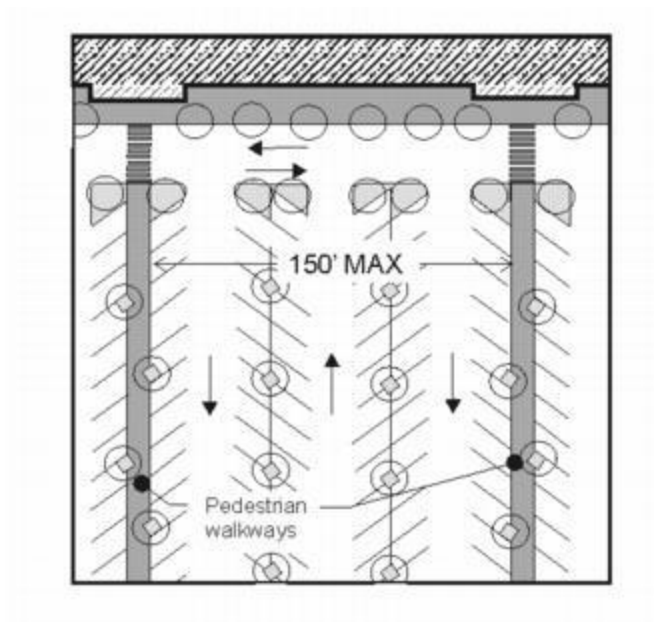

Figure 19. Parking lot pathway standards and example.

4. Internal Walkway Widths and Design.

a. Internal pathways along the front facade of mixed-use and retail buildings 100 feet or more in length (measured along the facade) that are not located adjacent to a street must be at least 12 feet wide with eight feet minimum unobstructed width and include the following:

- i. A minimum of one street tree per every 60 lineal feet of building facade must be provided. The street trees should be placed an average of 30 feet on-center and placed in grates (except where trees are placed in planting strips). Breaks in the tree coverage

will be allowed near major building entries to enhance visibility. However, no less than one tree per 60 lineal feet of building facade must be provided.

ii. Planting strips with a pathway of at least eight feet in width (with a combined pathway and planting strip of at least 14 feet in width) must be provided between any vehicular access or parking area and the pathway.



Figure 20. Internal walkway standards and an example along retail or mixed-use buildings.

b. For all other interior pathways, the applicant shall successfully demonstrate that the proposed walkway is of sufficient width to accommodate the anticipated number of users. See Figure 21 for considerations.

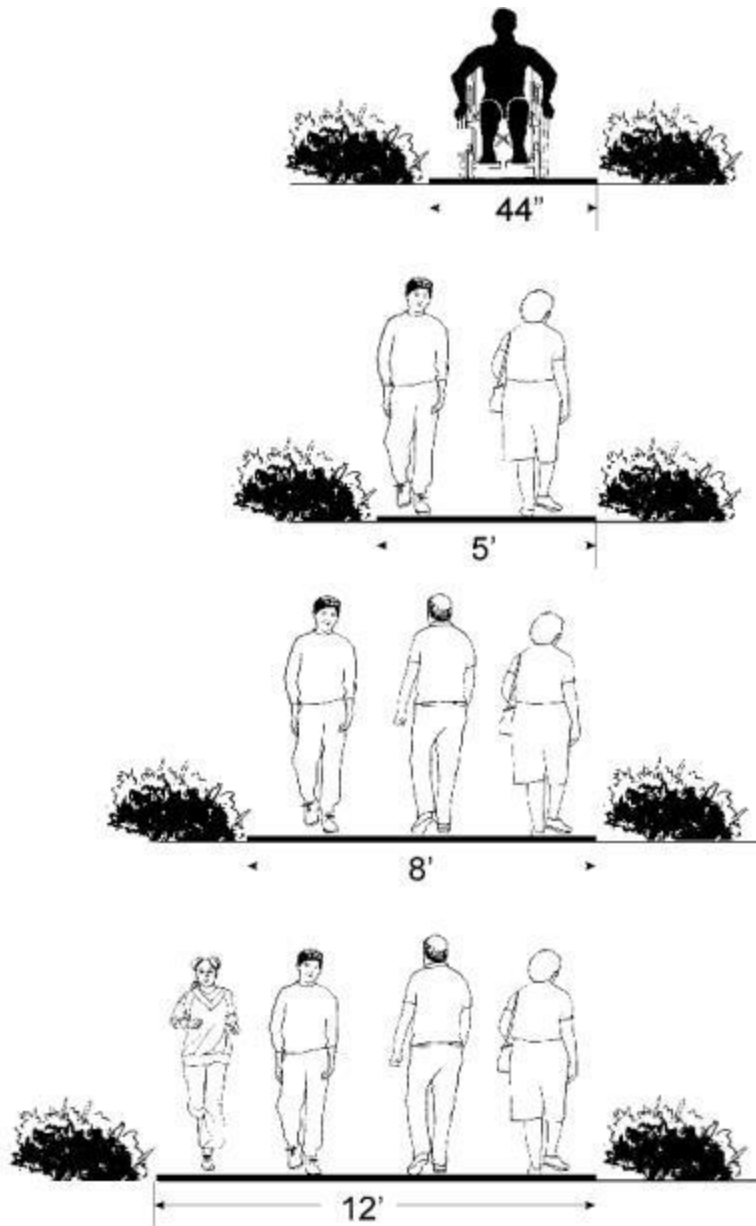

Figure 21. Considerations for pathway walking widths.

c. Pedestrian walks shall be separated from structures by at least three feet of landscaping, except where the adjacent building features a *pedestrian-oriented facade*.

DEPARTURES: The town shall consider alternative treatments to provide attractive pathways. Examples include the use of planter boxes and/or vine plants on walls, sculptural, mosaic, bas-relief artwork, or other decorative wall treatments that meet the intent of the standards. See Figure 23 for an example treatment that would meet the departure criteria.

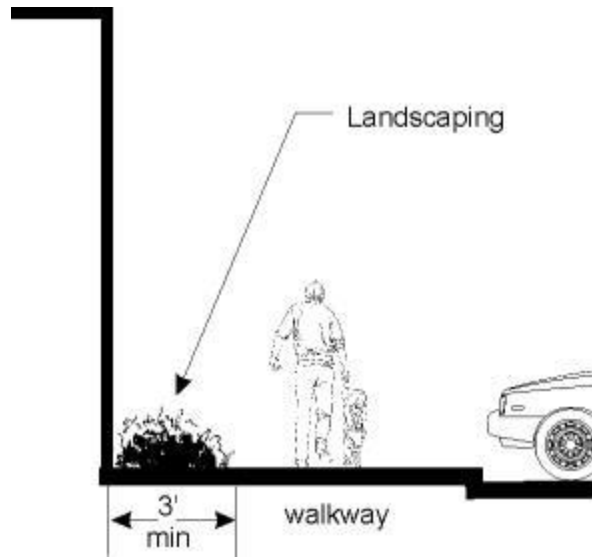

Figure 22. Separate internal pathways from buildings by landscaping.



Figure 23. A good departure example for a walkway along a non-pedestrian-oriented facade.

d. All internal walkways along *pedestrian-oriented facades* and walkways on the edge of parking areas shall feature at least one street tree for every 30 feet of walk. Trees may be spaced to maintain entry sign visibility.

5. Pedestrian Crossings.

- a. Crosswalks are required when a walkway crosses a paved area accessible to vehicles.
- b. Applicants must continue the sidewalk pattern and material across driveways.

B. Pedestrian Amenities.

1. Intent. To create attractive and comfortable pedestrian environments.
2. Durable Pedestrian Furniture. Pedestrian furniture provided in public spaces shall be made of durable, vandal- and weather-resistant materials that do not retain rainwater and can be reasonably maintained over an extended period of time.
3. Streetscape Amenity Options. Streetscape amenities should be included along all designated *storefront* streets, mixed-use streets, and gateway streets (see Figure 1 for applicable street type designations). For each 100 cumulative lineal feet of *storefront* street frontage, at least four of the desired amenity elements listed below should be included. Along designated mixed-use streets, at least two amenity elements shall be included. The type, location, and design of chosen amenities shall contribute to a well-balanced mix of features on the street, as determined by the planning director. Desired amenities include:
 - a. Seating. Each six feet of seating area or four individual seats count as one amenity element. Seating areas should generally be located in areas that provide views of pedestrian activity. Seating ledges must be at least 12 inches wide to qualify.
 - b. Trash Receptacles. To qualify as an amenity, at least one trash receptacle is needed per 100 linear feet of sidewalk. For designated pedestrian-oriented streets, this shall be required.
 - c. Permanent landscaping elements including planting beds and other landscaping elements that add visual interest to the sidewalk as determined by the planning director.
 - d. Special pavement patterns and/or tree grates.
 - e. Bicycle racks.
 - f. Informational kiosks (worth two amenity elements).
 - g. Decorative clocks (count as two amenity elements).
 - h. Artwork (counts as two amenity elements).
 - i. Special lighting.
 - j. Other amenities that meet the intent as determined by the planning director.

Features above that are publicly funded, already required by code, and/or obstruct pedestrian movement shall not qualify as an amenity to meet this standard.

All features are subject to planning director approval.



Figure 24. Streetscape amenity examples. Image 1 includes benches and several large potted plants; Image 2 includes similar features plus a decorative bench and a permanent planting

element; Image 3 is a decorative clock; Image 4 is a historical plaque; Image 5 is an informational kiosk; Image 6 includes decorative paving design/materials.



Figure 25. More streetscape amenity examples. Image 1 includes a decorative tree grate; Image 2 includes decorative artwork/paving related to the character and identity of the area; Image 3 is a

decorative bicycle rack; Image 4 includes a rain garden planting strip; Image 5 is a decorative bench; Image 6 includes a sitting ledge incorporating student artwork.

C. Service Elements and Mechanical Equipment.

1. Intent.

- a. To minimize the potential negative impacts of service elements.
- b. To encourage thoughtful siting of service elements that balance functional needs with the desire to screen negative impacts.

2. Service Element Location and Design. All developments shall provide a designated spot for service elements (refuse and disposal). Such elements shall meet the following requirements:

- a. Service elements shall be located to minimize the negative visual, noise, odor, and physical impacts to the street environment, adjacent (on- and off-site) residents or other uses, and pedestrian areas.
- b. The designated spot for service elements shall be paved with concrete.

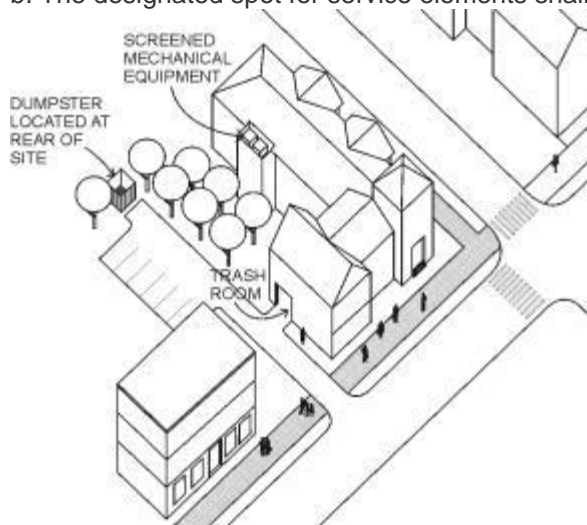



Figure 32. Appropriate service area location and enclosure example.

c. Appropriate enclosure of the common trash and recycling elements shall be required, as determined by the planning director. Requirements and considerations:

i. Service areas visible from the street, pathway, *pedestrian-oriented space* or public parking area (alleys are exempt) shall be enclosed and screened around their perimeter by a wall or fence at least six feet high. Developments are encouraged to use materials and detailing consistent with primary structures on-site. Acceptable materials include brick, concrete block or stone.

ii. The sides and rear of the enclosure must be screened with Type I, II, or III landscaping at least five feet deep in visible locations as determined by the planning director to soften the views of the screening element and add visual interest.

iii. Collection points shall be located and configured so that the enclosure gate swing does not obstruct pedestrian or vehicle traffic, or does not require that a hauling truck project into any public right-of-way.

iv. Weather protection of recyclables shall be ensured by using weather-proof containers or by providing a roof over the storage area.

v. Proximity to adjacent residential units will be a key factor in determining appropriate service element treatment.

vi. Preferably, service enclosures are integrated into the building itself.

3. Utility Meters, Electrical Conduit, and Other Service Utility Apparatus. These elements shall be located and/or designed to minimize their visibility to the public. Project designers are strongly encouraged to coordinate with applicable service providers early in the design process to determine the best approach in meeting these standards. If such elements are mounted in a location visible from the street, pedestrian pathway, common open space, or shared auto courtyards, they shall be screened with vegetation or by architectural features.



Figure 33. Good and bad utility meter configurations. The examples on the top are consolidated and somewhat screened by landscaping elements, whereas the bottom examples are exposed and degrade the character of these townhomes.

4. Rooftop Mechanical Equipment. All rooftop mechanical equipment shall be organized, proportioned, detailed, screened, landscaped (with decks or terraces) and/or colored to be an integral element of the building and minimize visual impacts from the ground level of adjacent

streets and properties. For example, screening features should utilize similar building materials and forms to blend with the architectural character of the building.

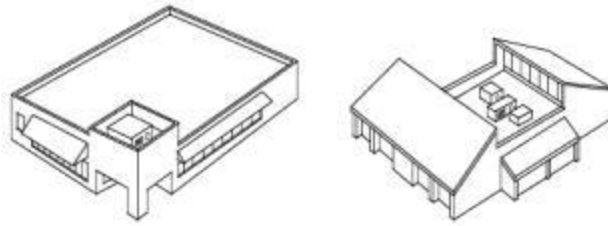

Figure 34. Screening examples of rooftop mechanical equipment.

D. Lighting.

1. Intent.

- a. To encourage the judicious use of lighting in conjunction with other security methods to increase site safety.
- b. To encourage the use of lighting as an integral design component to enhance buildings, landscaping, and other site features.
- c. To encourage night sky visibility and to reduce the general illumination of the sky in Eatonville.
- d. To reduce the horizontal glare and vertical light trespass from a development onto adjacent parcels and natural features.
- e. To discourage the use of lighting for advertising purposes.

2. Lighting Standards and Guidelines. Provide appropriate lighting levels in all areas used by pedestrians or automobiles, including building entries, walkways, parking areas, circulation areas, and other open space areas.

New developments shall provide site lighting that meets the following design criteria through implementing measures such as:

- a. All public areas shall be lighted with average minimum and maximum levels as follows:
 - i. Minimum (for low or non-pedestrian and vehicular traffic areas) of 0.5 foot candles;

ii. Moderate (for moderate or high volume pedestrian areas) of one to two foot candles;
and

iii. Maximum (for high volume pedestrian areas and building entries) of four foot candles.

b. Lighting shall be provided at consistent levels, with gradual transitions between maximum and minimum levels of lighting and between lit areas and unlit areas. Highly contrasting pools of light and dark areas shall be avoided.

c. Parking lot lighting fixtures shall be non-glare and mounted no more than 25 feet above the ground, with lower fixtures preferable so as to maintain a human scale. Requests for higher lighting fixtures may be considered with the approval of the planning director. All fixtures over 15 feet in height shall be fitted with a full cut-off shield.

d. Pedestrian-scaled lighting (light fixtures no taller than 15 feet) is encouraged in areas with high anticipated pedestrian activity. Lighting shall enable pedestrians to identify a face 45 feet away in order to promote safety.

e. Lighting should not be permitted to trespass onto adjacent private parcels nor shall light source (luminaire) be visible at the property line. All building lights shall be directed onto the building itself and/or the ground immediately adjacent to it. The light emissions should not be visible above the roofline of the building. Light fixtures other than traditional cobra heads are encouraged.

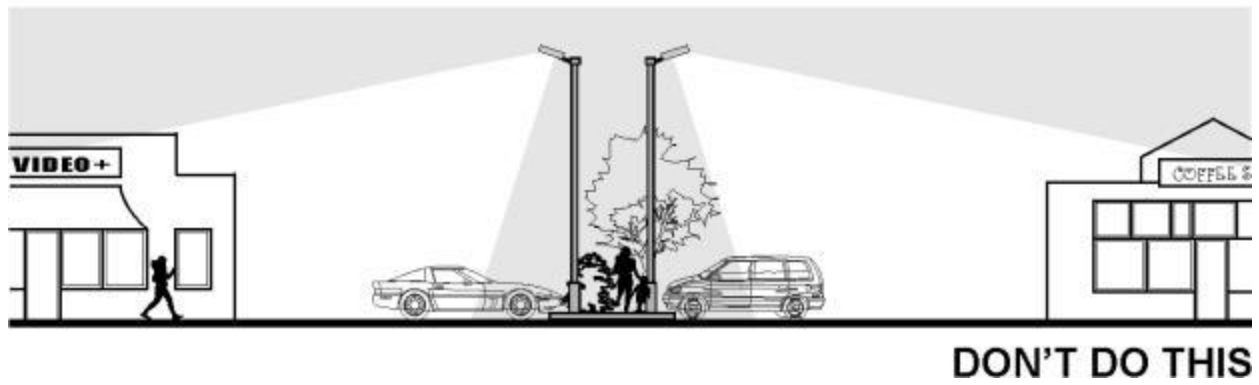
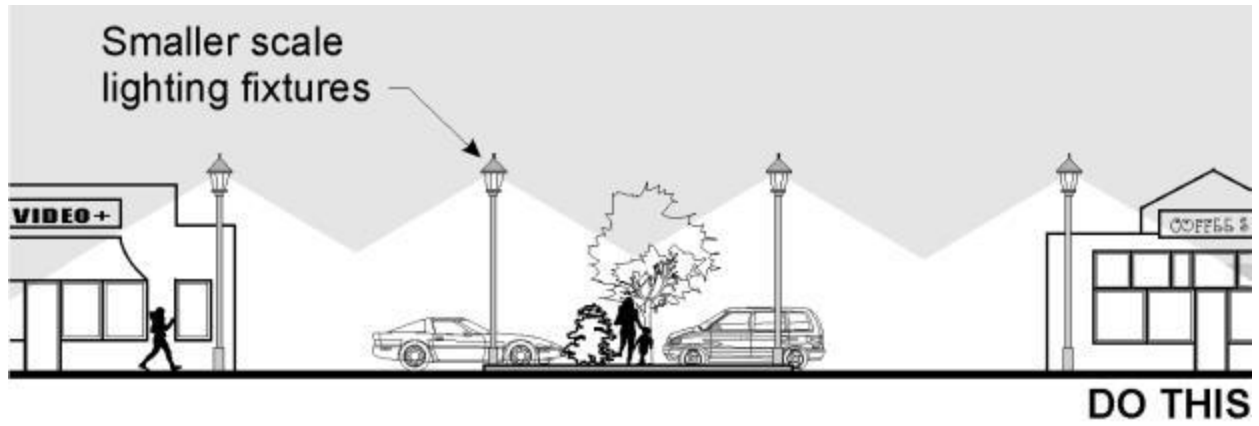

Figure 35. Lighting guidelines.



Figure 35 (continued). Lighting guidelines.

(Ord. 2010-09 § 1, 2010).

19.03.030 Building design.

This chapter addresses standards and guidelines for the design of buildings, including the architectural vision, scale and massing, building corners, building details and materials, and *blank wall* treatments.

A. Architectural Vision.

1. Intent.

a. To promote architectural design that reinforces and strengthens Eatonville's unique small town/historic mill town character/Mt. Rainier gateway location.

2. Architectural Character Standards and Guidelines. The architectural character standards seek to reinforce and strengthen Eatonville's unique small town/historic mill town/Mt. Rainier gateway

character/location by emphasizing the use of natural stone (preferably local), brick (which is evident in many remaining older commercial buildings and was locally produced), the use of heavy timbers, and/or natural wood siding (consistent with the area's location, history, and setting).

All new non-residential structures shall utilize at least one of the following materials on their primary facade:

- a. Natural stone/rock covering at least 10 percent of the ground floor facade. The use of local materials such as round river rock is encouraged.
- b. Use of brick covering at least 20 percent of the ground floor facade.
- c. Use of exposed heavy timbers to accentuate rooflines, building entries, windows, or weather protection elements.
- d. Use of natural wood siding (stained, but not painted) as the predominant material (other than glass). This includes traditional forms of horizontal wood siding, board and batten, and use of shingles, but does not include T-111 siding or other similar plywood or sheet materials.

For other standards relating to building materials see subsection C of this section.

The images in Figure 36 on the following page exemplify the desired architectural character by integrating one or more of the materials used above.

DEPARTURES. The use/mix of alternative materials may be considered by the town where the applicant can successfully demonstrate that the design meets the intent of the standards.



Figure 36. Desirable architectural character incorporating the use of preferred materials.

3. No Corporate Architecture. Architecture that is defined predominantly by corporate identity features is prohibited. For example, some fast food franchises have very specific architectural features that reinforce their identity. Buildings that act as signs are prohibited.



Figure 37. Franchise fast food restaurants that modified their standard corporate design to fit into desired local design character (these do not necessarily fit Eatonville’s desired character, but they show how the franchises can modify their design if they want to be in a particular community).

B. Architectural Scale/Massing.

1. Intent.

a. To ensure that new buildings are consistent with the character and massing of the town’s existing conforming buildings.

b. To enhance the visual character of Eatonville.

2. Building *Articulation – Storefronts*. All buildings adjacent to *storefront* streets or featuring a *pedestrian-oriented facade* built up to the sidewalk edge. Buildings must

include *articulation* features no more than every 40 feet to create a pattern of small *storefronts*. Buildings less than 60 feet wide are exempt from this standard. At least two of the following methods must be employed:

- a. Use of window and/or entries that reinforce the pattern of 40-foot *storefront* spaces.
- b. Use of weather protection features that reinforce 40-foot *storefronts*. For example, for a business that occupies 120 feet of frontage, use three separate awnings to break down the scale of the *storefronts*. Alternating colors of the awnings may be useful as well.
- c. Change of roofline per subsection (B)(6) of this section.
- d. Use of vertical piers that reinforce *storefront* pattern.
- e. Change in building material or siding style.
- f. Other methods that meet the intent of the standards as approved by the planning director.

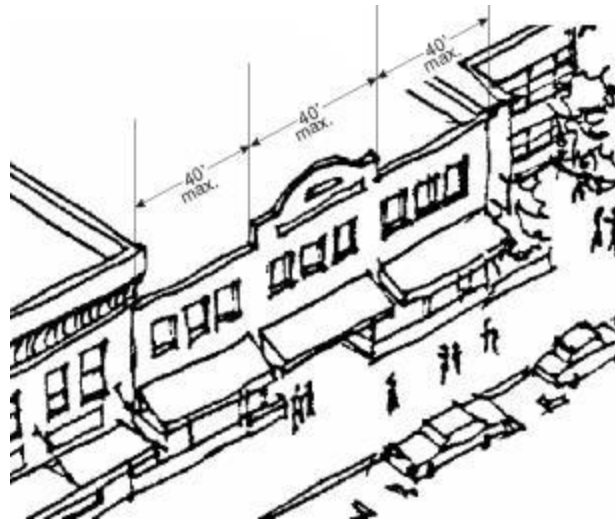

Figure 38. Storefront articulation standards.

DEPARTURES will be considered by the town provided the design meets the intent of the standards. For example, the proposed *articulation* may be longer, but if the building features attractive detailing, materials, interesting roofline treatments, and interesting *storefront* design that helps the design fit into the site's context and contributes to the pedestrian environment and existing/desired character, then perhaps it should be an approved departure.



Figure 39. Facades that meet (top image) and don't meet (bottom image) the storefront articulation standards. The top image uses repeating window/storefront patterns, separate weather protection elements, and vertical piers to successfully articulate the facade. The bottom image uses continuous window and weather protection elements and thus wouldn't comply with the standards.

3. Building *Articulation* – Other Non-Residential/Mixed-Use Buildings. All other buildings featuring non-residential uses on the ground floor (not covered in subsection (B)(2) of this section) shall include at least three of the following *articulation* features along all facades containing the public building entries (alley facades are exempt) at intervals of no more than 60 feet.

- a. Providing vertical building *modulation* of at least two feet in depth and four feet in width if combined with a change in siding materials and/or roofline *modulation* per subsection (B)(6) of this section. Otherwise, the vertical *modulation* shall be at least 10 feet deep and 15 feet wide to qualify.

- b. Providing horizontal *modulation* (upper level stepbacks). To qualify for this measure, the minimum upper level stepback shall be at least five feet and the treatment shall be used consistently with other *articulation* elements or utilized along at least 75 percent of the facade.
- c. Repeating distinctive window patterns at intervals less than the *articulation interval*.
- d. Providing a covered entry or separate weather protection feature for each *articulation interval*.
- e. Use of vertical piers that reinforce *storefront* pattern. To qualify for this measure, the piers must project at least two inches from the facade and extend from the ground to the roofline.
- f. Change of roofline per subsection (B)(6) of this section.
- g. Changing materials and/or color with a change in building plane.
- h. Providing lighting fixtures, *trellis*, tree, or other landscape feature within each interval.
- i. Other methods that meet the intent of the standards as approved by the planning director.

DEPARTURES will be considered by the town provided the design meets the intent of the standards. Elements to consider are the level of detailing, quality of building materials, design of *storefronts*, and integration with or enhancement of the surrounding context.

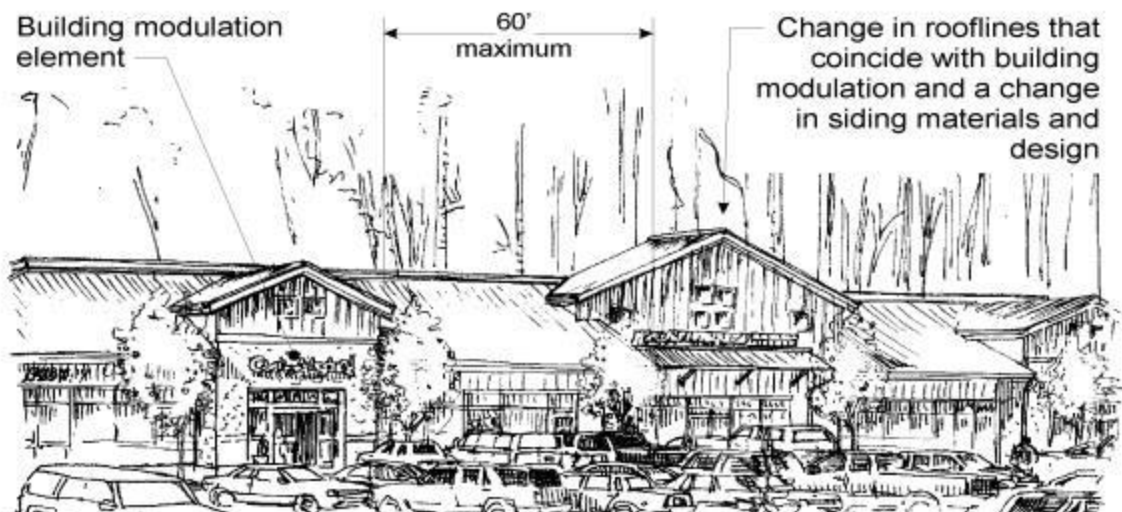

Figure 40. Building articulation example for other non-storefront commercial facades.

4. Building *Articulation* – Multifamily Buildings. All multifamily buildings and residential portions of mixed-use buildings shall include at least three of the following *articulation* features at intervals of no more than 30 feet along all facades facing a street, common open space, and common parking areas:

- a. Repeating distinctive window patterns at intervals less than the required interval.
- b. Providing vertical building *modulation*. Minimum depth and width of *modulation* is 18 inches and four feet (respectively) if tied to a change in color or building material and/or roofline *modulation* as defined in subsection (B)(6) of this section. Otherwise, minimum depth of *modulation* is 10 feet and minimum width for each *modulation* is 15 feet. *Balconies* may not be used to meet the *modulation* option unless they are recessed or projected from the facade and integrated with the building's architecture as determined by the planning director. For example, "cave" balconies or other balconies that appear to be "tacked on" to the facade will not qualify for this option.
- c. Change of roofline per subsection (B)(6) of this section.
- d. Providing horizontal *modulation* (upper level stepbacks). To qualify for this measure, the minimum upper level stepback shall be at least five feet and the treatment shall be used consistently with other *articulation* elements or utilized along at least 75 percent of the facade.
- e. Articulating of the building's top, middle, and bottom. This includes a distinctive ground floor or lower floor design, consistent *articulation* of middle floors, and a distinctive roofline (see Figure 41 for an example).

DEPARTURES will be considered by the town provided the design meets the intent of the standards. Elements to consider are the level of detailing, quality of building materials, types of articulated features, and integration with or enhancement of the surrounding context.



Figure 41. Multifamily facade articulation example. Note roofline changes, use of balconies, and delineation of the facade’s top, middle, and bottom. Changes in materials or siding (noted by use of different shades here) can also be effective in breaking up the scale of the building and adding visual interest.

5. Roofline Design Options. Rooflines visible from a public street, open space or public parking area must meet one of the following design options:

- a. Comply with roofline *modulation* provisions per subsection (B)(6) of this section.
- b. Provide a *cornice* of two parts with the top projecting at least six inches from the face of the building and the bottom part featuring a concave design or projecting at least two inches from the facade, but extending no less than two inches from the facade than the top part (see Figure 42 for examples). The height of the *cornice* (both parts combined) shall be at least 12 inches for buildings 20 feet or less in height; 18 inches for buildings greater than 20 feet and less than 30 feet in height; and 24 inches for buildings 30 feet and greater in height. *Cornices* shall not project over property lines, except where permitted on property lines abutting public rights-of-way. The *cornice* line must extend along at least 75 percent of the facade.
- c. Provide a *cornice* element that projects at least 18 inches from the facade. The *cornice* line must extend along at least 75 percent of the facade.

See Figures 42 and 43 below for acceptable *cornice* examples.

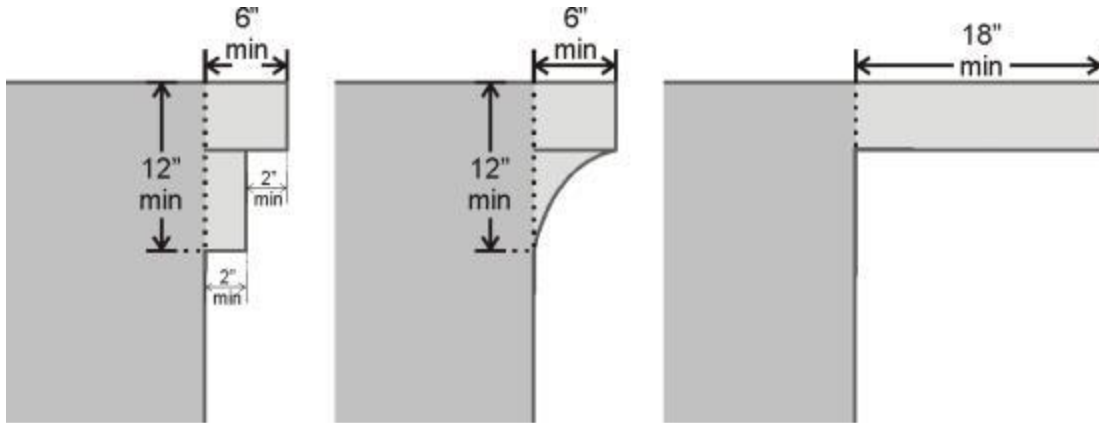

Figure 42. Acceptable cornice design options.



Figure 43. Acceptable cornice examples.

6. Roofline *Modulation*. In order to qualify as a roofline *modulation* treatment in the standards herein, rooflines shall be varied by emphasizing dormers, chimneys, stepped roofs, gables, or a broke or articulated roofline consistent with the required *articulation interval*. *Modulation* shall consist of either:

a. For flat roofs or facades with horizontal eave, fascia, or parapet, the minimum vertical dimension of roofline *modulation* is the greater of two feet or 0.1 multiplied by the wall height (finish grade to top of the wall) when combined with vertical building *modulation* techniques described in subsections (B)(2), (B)(3), and (B)(4) of this section. Otherwise, the minimum vertical dimension of roofline *modulation* is the greater of four feet or 0.2 multiplied by the wall height.

b. A sloped or gabled roofline segment of at least 20 feet in width and a minimum slope of 6:12. The roofline must include modulated segments at no more than the interval required per the applicable standard above.

c. A combination of the above.

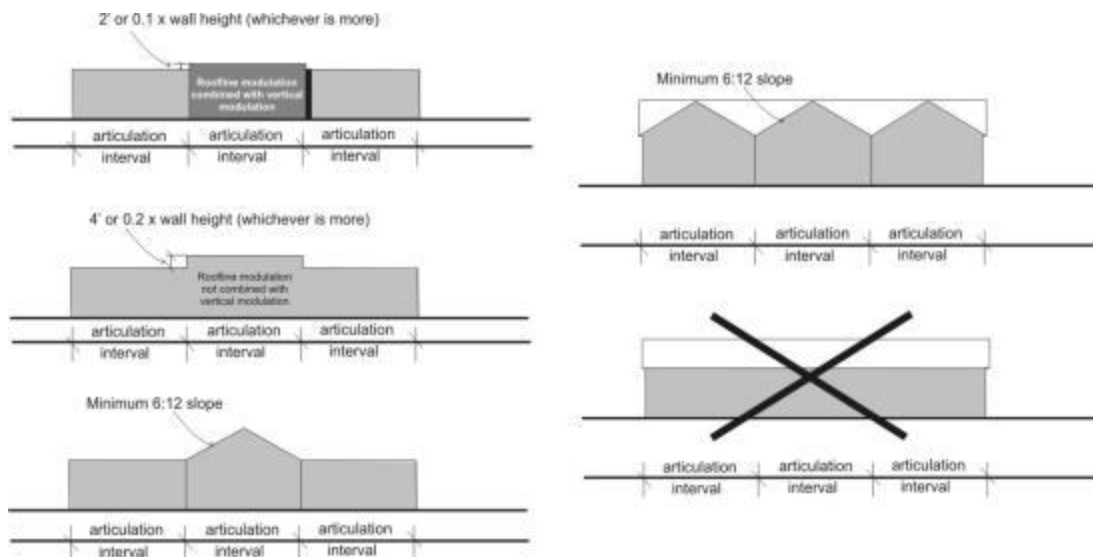

Figure 44. Roofline modulation standards.

7. Maximum Facade Width. The maximum facade width (facades facing the street or customer parking lot) is 100 feet.

Exceptions: Buildings exceeding 100 feet in width shall incorporate significant *modulation* and/or *articulation* features that effectively break up the scale of the building and add visual interest from the street. Such buildings shall incorporate at least one of the following design elements:

a. Provide vertical building *modulation* at least 10 feet deep and 20 feet wide. For multi-story buildings the *modulation* must extend through more than one-half of the building floors.

b. Use of a contrasting vertical modulated design component featuring all of the following:

i. Component extends through all floors above the first floor fronting on the street.

Exception: Upper floors that are stepped back more than 10 feet from the facade are exempt.

ii. Utilizes a change in building materials that effectively contrast from the rest of the facade.

iii. Component is modulated vertically from the rest of the facade by an average of six inches. The planning director may exempt *storefront* buildings from this provision provided all other standards herein are met and the design effectively meets the intent of the standards.

iv. Component is designed to provide roofline *modulation* per subsection (B)(6) of this section.

c. Facade employs building walls with contrasting *articulation* that make it appear like two distinct buildings. To qualify for this option, these contrasting facades must employ both of the following:

i. Different building materials and/or configuration of building materials.

ii. Contrasting window design (sizes or configurations).

DEPARTURES will be considered by the town provided the design meets the intent of the standards. Elements to consider are the level of detailing, quality of building materials, type of articulated features, and integration with or enhancement of the surrounding context (considering views from all publicly observable locations within town).

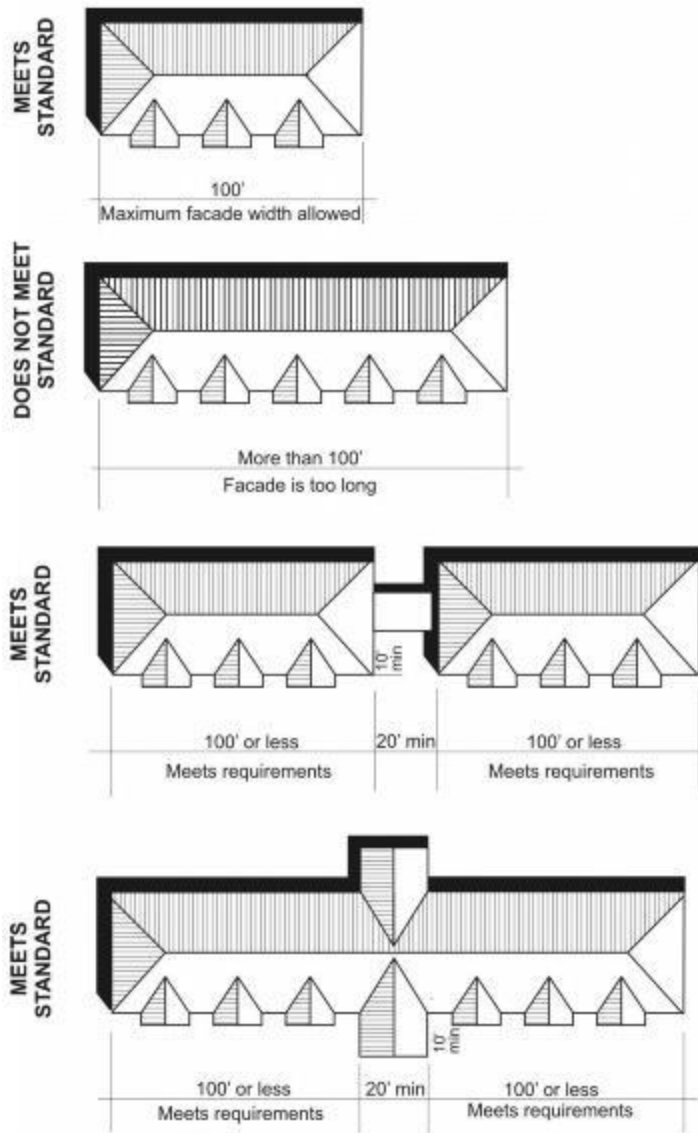

Figure 45. Maximum facade width standards and good/bad examples. Photo example A successfully uses a change in building materials, roofline, and window fenestration. Photo example B, while showing a building somewhat large for Eatonville, shows how a combination of facade and roofline modulation helps to break down the scale of the building and add visual interest. Photo example C does not include any of the optional design elements and thus would not meet the maximum facade width requirements.

C. Building Corners – Applicability. The standards herein apply only to buildings located within 30 feet of a designated high visibility street corner per Figure 16.

1. Intent.

- a. To promote distinctive building design features at high visibility street corners.

2. High Visibility Street Corner Building Design Options. Applicable street corner buildings shall provide one or more of the elements listed below on both sides of an axis running diagonally through the corner of the building and bisecting the angle formed by the two building facades:

- a. A cropped building corner with corner pedestrian entry.
- b. A *bay window* or *turret*.
- c. *Balconies* above the ground floor.
- d. Sculpture or artwork element; must be a one-of-a-kind design element.
- e. Distinctive use of facade materials.
- f. Other special or unique corner building treatment, other than the use of fabric or vinyl awnings, for pedestrian weather protection at the corner of the building as determined by the planning director.

All corner building design elements must be sized to be proportional to the building and the size of the applicable intersection, as determined by the planning director (for example, larger intersections warrant more substantial design treatments).





Figure 46. Desirable building corner examples.

D. Building Details.

1. Intent.

- a. To encourage the incorporation of design details and small-scale elements into building facades to enhance the pedestrian environment.

2. Facade Details Toolbox. All non-residential and mixed-use buildings shall be enhanced with appropriate details. All new buildings must employ at least one detail element from each of the three categories below for each facade facing a street or public space. For example, a large building with multiple *storefronts* will likely need more than one decorative sign, one transom window, and one decorative kick-plate to meet the intent of the standards.

a. Window and/or entry treatment:

- i. Display windows divided into a grid of multiple panes.
- ii. Transom windows.
- iii. Roll-up windows/doors.
- iv. Other distinctive window treatment that meets the intent of the standards.
- v. Recessed entry.
- vi. Decorative door.

vii. *Arcade*.

viii. Landscaped *trellises* or other decorative element that incorporates landscaping near the building entry.

b. Building elements and facade details:

i. Custom-designed weather protection element such as a steel canopy, cloth awning, or retractable awning.

ii. Decorative, custom hanging sign(s).

iii. Decorative building-mounted light fixtures.

iv. *Bay windows*, *trellises*, towers, and similar elements.

c. Building materials and other facade elements:

i. Decorative building materials/use of building materials. Examples include decorative use of brick, tile, or stonework.

ii. Artwork on building (such as a mural) or bas-relief sculpture.

iii. Decorative kick-plate, pier, beltcourse, or other similar feature.

iv. Hand-crafted material, such as special wrought iron or carved wood.

“Custom,” “decorative,” or “hand-crafted” elements referenced above must be distinctive or “one-of-a-kind” elements or unusual designs that require a high level of craftsmanship as determined by the planning director.



Figure 47. Acceptable facade detailing examples. The left image includes decorative window and roofline treatment on the corner plus decorative brick and stonework and metal awnings. The right image uses decorative stone and shinglework, decorative windows, and a decorative entry feature.

3. Window Design. Buildings shall employ techniques to recess or project individual windows above the ground floor at least two inches from the facade or incorporate window trim at least four inches in width that features color that contrasts with the base building color.

DEPARTURES will be considered by the town where buildings employ other distinctive window or facade treatment that adds a sense of depth to the facade and/or visual interest to the building.



Figure 48. Acceptable and unacceptable (far right image) window design on upper floors. Note that the two windows on the left are recessed; the image right center shows a window with trim. The image on the right includes no trim or recess/projection.

4. Year of Construction Plaque. All new commercial and mixed-use buildings must note the year of construction of a building by the installation of a plaque attached to the building. Numbers etched

into stone, brick, or concrete may be used in lieu of a plaque. The year of construction is to be noted by numbers not less than six inches high. Other information associated with the building that may be of public interest may be included.

E. Building Materials – Applicability. The standards below are in addition to the material standards in subsection A of this section, Architectural Vision.

1. Intent.

- a. To encourage high-quality building materials that reinforce the historic small town character of Eatonville.
- b. To discourage poor materials with high life-cycle costs.
- c. To encourage the use of materials that reduce the visual bulk of large buildings.

2. Metal Siding Standards. Metal siding may be used if it is incorporated with one of the materials required in subsection (E)(1) of this section and it complies with the following:

- a. It features visible corner molding and trim and does not extend lower than two feet above grade. Masonry, concrete, or other durable material must be incorporated between the siding and the ground plane.
- b. Metal siding shall be factory finished, with a matte, non-reflective surface.

3. Concrete Block Standards. Concrete block may be used if it is incorporated with one of the materials required in subsection (E)(1) of this section and it complies with the following:

- a. When used for the primary facade, buildings must incorporate a combination of textures and/or colors to add visual interest. For example, combining split or rock-facade units with smooth blocks can create distinctive patterns.
- b. Concrete block may comprise no more than 50 percent of a facade facing a public right-of-way or open space.

4. Standards for Stucco or Other Similar Troweled Finishes. Such material/finishes may be used if it is incorporated with one of the materials required in subsection (E)(1) of this section and it complies with the following:

a. Stucco and similar troweled finishes (including exterior insulation and finish system or “EIFS”) must be trimmed in wood, masonry, or other material and must be sheltered from extreme weather by roof overhangs or other methods and are limited to no more than 50 percent of the facade area facing a public right-of-way or open space.

b. Horizontal surfaces exposed to the weather must be avoided.

c. Stucco, EIFS, and similar surfaces should not extend below two feet above the ground plane. Concrete, masonry, or other durable material must be used below the two-feet-above-grade line to provide a durable surface where damage is most likely.



Figure 49. Acceptable mixes of building materials. Image A emphasizes brick; Image B mixes stucco, brick, and concrete block with metal weather protection elements; Image C mixes metal siding with heavy timbers; and Image D emphasizes stonework on the building's corner.

5. Prohibited Materials.

- a. Mirrored glass where used on more than 10 percent of the facade.
- b. T-111 siding and similar processed sheet products.
- c. Chain-link fencing (except for temporary fencing and for parks).
- d. Fiberglass products and similar sheet products.
- e. Back-lit vinyl awnings used as signs.

F. *Blank Walls*.

1. Intent.

- a. To avoid untreated *blank walls*.

2. *Blank Wall* Definition. A wall (including building facades and retaining walls) is considered a *blank wall* if:

- a. A ground floor wall or portion of a ground floor wall over six feet in height has a horizontal length greater than 15 feet and does not include a transparent window or door; or
- b. Any portion of a ground floor wall having a surface area of 400 square feet or greater does not include a transparent window or door.

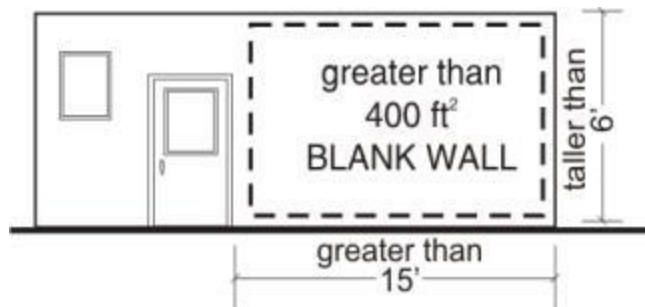

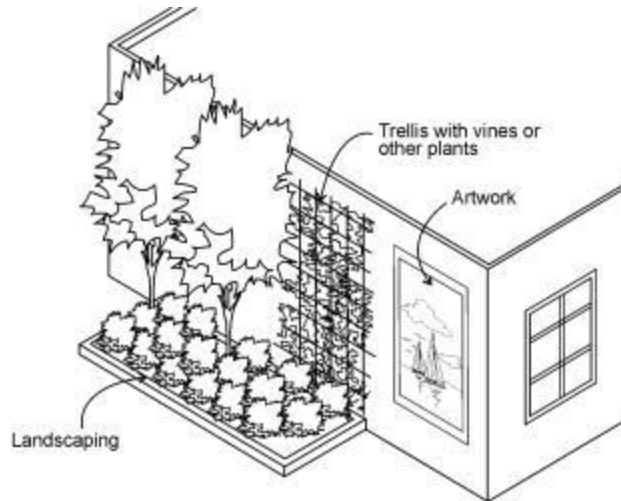

Figure 50. Blank wall definition and treatment examples.

3. *Blank Wall Standards*. Untreated *blank walls* visible from a public street or pedestrian pathway are prohibited. Methods to treat *blank walls* can include:

- a. Display windows at least 16 inches of depth to allow for changeable displays. Tack on display cases shall not qualify as a *blank wall* treatment.
- b. Landscape planting bed at least five feet wide or a raised planter bed at least two feet high and three feet wide in front of the wall with planting materials that are sufficient to obscure or screen at least 60 percent of the wall's surface within three years.
- c. Installing a vertical *trellis* in front of the wall with climbing vines or plant materials.
- d. Special building detailing that adds visual interest at a pedestrian scale. Such detailing must use a variety of surfaces; monotonous designs will not meet the intent of the standards.

For large visible *blank walls*, a variety of treatments may be required to meet the intent of the standards.



Figure 51. Good and bad blank wall treatment examples. Image A illustrates that heavy landscaping can be very effective in treating a large blank wall. Image B uses a combination of planted trellises and display ads integrated with the building’s architecture along a facade facing a drive-through. Image C simply doesn’t use enough treatments and the result is a stark and unwelcome streetscape.

(Ord. 2010-09 § 1, 2010).

Chapter 19.04 DESIGN STANDARDS FOR DETACHED SINGLE-FAMILY USES AND DUPLEXES

Sections:

- 19.04.010 Purpose and applicability.**
- 19.04.020 Detached single-family uses.**
- 19.04.030 Duplexes.**

19.04.010 Purpose and applicability.

A. Purpose.

1. To ensure that developments are compact, pedestrian friendly, and contribute to the character of the town and surrounding neighborhood.
2. To create variety and interest in residential streets.
3. To integrate open space and natural features into developments.
4. To minimize impacts to the natural environment.

B. Applicability. The standards in this chapter shall apply to detached single-family uses, accessory dwelling units, and duplexes in any zone they are built within.

C. Requests for exceptions within this chapter shall not exceed three. (Ord. 2018-14 § 2 (Exh. A) 2018; Ord. 2010-09 § 1, 2010).

19.04.020 Detached single-family uses.

A. Garage Placement and Design.

1. Where lots front on a public street and where vehicular access is from the street, garages or carports shall be set back at least five feet behind the front wall of the house or front edge of an unenclosed porch. On corner lots, this standard shall only apply to the designated front yard. Lots within a designated low impact subdivision (see EMC [19.06.030](#)) are exempt from this standard.

Exceptions:

a. Garages may project up to six feet closer to the street than the front wall of the house or front edge of an unenclosed porch provided it is set back at least 20 feet from the street and incorporates at least two of the design/detail features below. Garages placed flush with the front wall of the house shall incorporate at least one of the design/detail features below:

- i. A decorative *trellis* over the entire garage.
- ii. A *balcony* that extends out over the garage and includes columns.
- iii. Two separate doors for two car garages instead of one large door.
- iv. Decorative windows on the garage door.
- v. Decorative details on the garage door. Standard squares on a garage door will not qualify as a decorative detail.
- vi. A garage door color (other than white) that matches or complements the color of the house.
- vii. Other design techniques that effectively deemphasize the garage, as determined by the planning director.

b. Garages may be placed closer to the street than the front wall of the house or front edge of an unenclosed porch provided it faces towards the side yard and features a window facing the street so that it appears to be habitable.

2. The garage face shall occupy no more than 50 percent of the ground-level facade facing the street.

3. Where lots abut an opened alley, the garage or off-street parking area shall take access from the alley, unless precluded by steep topography.

4. Exceptions.

a. A garage proposed on a lot greater than one-half acre in size may request an exception from the garage placement and design standards of subsections (A)(1), (2) and (3) of this section; or

b. A garage proposed on a lot that is less than one-half acre in size may request an exception from the garage placement and design standards of subsections (A)(1), (2) and (3) of this section when the proposed garage is more than 150 feet from another lot with a garage that does not comply with the garage placement and design standards herein; or

c. A garage proposed on a lot having a unique configuration, attribute or overall project design element may request an exception from the garage placement standards of subsections (A)(1), (2) and (3) of this section. It shall be the applicant's responsibility to successfully demonstrate:

i. The unique and individual circumstances that justify an exception; and

ii. If granted, how the resulting development will meet the intent of the design standards and be compatible with the existing and/or future development of the neighborhood.

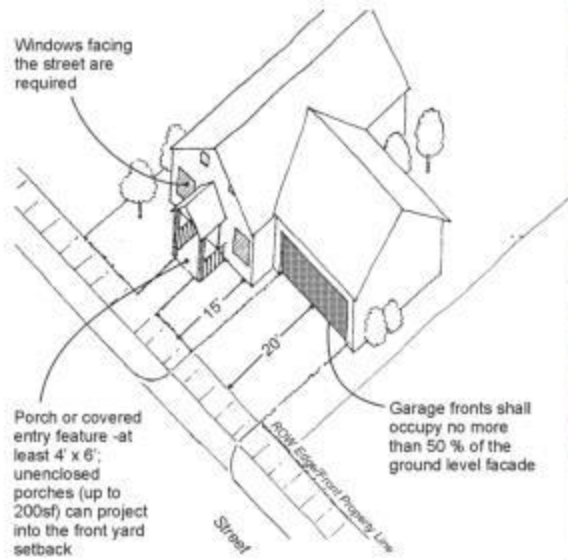

Figure 1. Garage placement/frontage standards and design example.



Figure 2. Examples of garage design/detail examples.

B. Vehicular Access and Driveway Standards. All lots with alleys shall take vehicular access from the alley. Standards for all other lots without alleys:

1. No more than one driveway per dwelling unit.
2. Driveways for individual lots 50 feet or wider may be up to 20 feet in width.
3. Driveways for individual lots less than 50 feet wide may be up to 12 feet in width. Tandem parking configurations may be used to accommodate two-car garages.

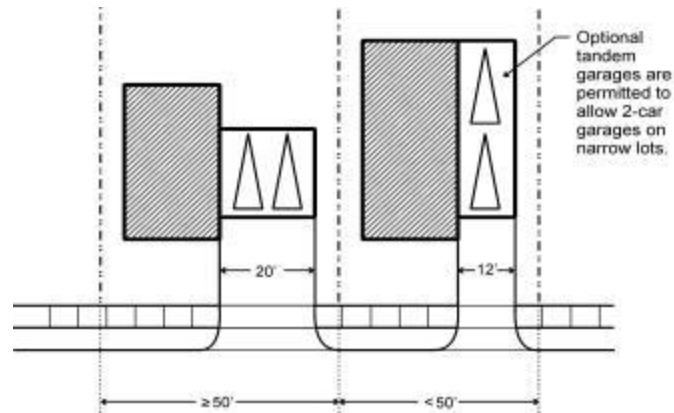

Figure 3. Driveway standards.

4. Exceptions.

a. Vehicular access and driveways proposed on lots that are greater than one-half acre in size and are not less than 100 feet in width along the lot frontage may have a driveway width of up to 24 feet; or

b. A lot determined by the director to have a unique configuration or attribute that warrants consideration of an exception may request an exception to the vehicular access and driveway standards. It shall be the applicant's responsibility to successfully demonstrate:

- i. The unique and individual circumstances that justify an exception; and
- ii. If granted, how the resulting development will meet the intent of the design standards and be compatible with the existing and/or future development of the neighborhood.

C. Building Design.

1. Covered Entry. All houses shall provide a covered entry with a minimum dimension of four feet by six feet. Porches up to 200 square feet may project into the required front yard by up to six feet. See Figure 1 for an example.

2. Windows and Transparency.

a. Transparent windows and/or doors facing the street are required. To meet this requirement, at least 10 percent of the facade must be transparent. The facade is measured from the base of the house to the start of the roofline and any other vertical walls facing the street, except for

gabled portions of the facade not containing livable floor area (see Figure 4 for clarification).
Garages facing the street shall count as part of the facade.

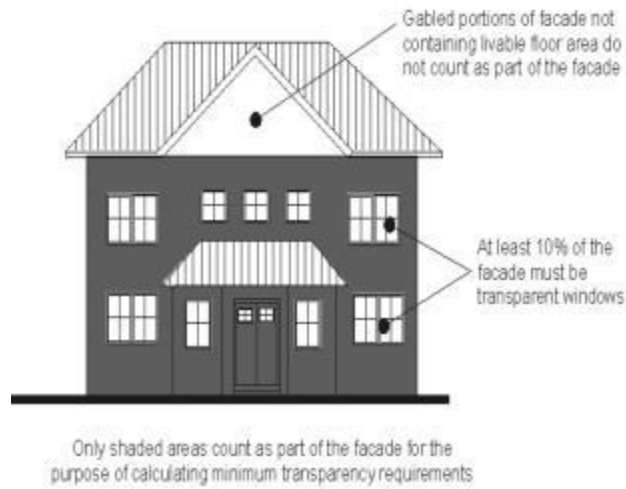

Figure 4. Facade transparency.

b. Building facades visible from a public street shall employ techniques to recess or project individual windows above the ground floor at least two inches from the facade or incorporate window trim at least four inches in width that features color that contrasts with the base building color. Exceptions will be considered where buildings employ other distinctive window or facade treatment that adds depth and visual interest to the building.



Figure 5. Acceptable (left and middle) and unacceptable (right) window design.

3. Architectural Details. Provide for architectural details that add visual interest to the neighborhood and are well proportioned to achieve good human scale. Specifically, incorporate at least three of the following detail elements into the facade of the house:

- a. Decorative porch design, including decorative columns or railings.
- b. *Bay windows* or balconies.
- c. Decorative molding/framing details around all ground floor windows and doors.
- d. Decorative door design including transom and/or side lights or other distinctive feature.
- e. Decorative roofline elements including brackets, multiple dormers, and chimneys.
- f. Decorative building materials, including decorative masonry, shingle, brick, tile, stone, or other materials with decorative or textural qualities.
- g. Landscaped *trellises* or other decorative elements that incorporate landscaping near the building entry.
- h. Distinctive paint schemes.
- i. Exceptions: Other decorative facade elements or details that meet the intent and standards as determined by the planning director.



Figure 6. Examples of how houses can meet architectural detail criteria. Image A includes decorative windows, building material treatment, and roofline elements. Image B includes decorative brick use, window treatments, entry design, and ventilation circles. Image C includes decorative building materials, door/entry feature, windows, and roofline elements.

4. Architectural Variety. Developments shall achieve architectural variety by accommodating a variety of architectural styles, variations of the same architectural style, and through the use of multiple design elements. Specifically:

a. Duplicative house designs adjacent to each other are prohibited. Simple reverse configurations of the same house design on adjacent lots are not sufficient to meet architectural variety goals. Exceptions may be granted by the planning director in special circumstances where similar architectural consistency provides a distinct character for a cluster of homes surrounding an open space or on a particular street (cottage homes around a common open space are an example).

b. Generally, the more houses in a subdivision, the greater the number of different facade elevations will be required. Specifically:

- i. Ten to 19 homes, a minimum of four different facade elevations shall be used.
- ii. Twenty to 39 homes, a minimum of five different facade elevations shall be used.
- iii. Forty to 69 homes, a minimum of six different facade elevations shall be used.
- iv. Seventy or more homes, a minimum of seven different facade elevations shall be used.



Figure 7. Examples of homes featuring different facade elevations. Notice the different rooflines, entry features, window designs/locations, exterior materials, and colors.

c. In order to qualify as a different facade elevation, dwellings shall have different roofline configurations, different color palettes, and different porch/entry design. In addition, a minimum of two of the following alternatives shall be utilized:

- i. Different window openings (location and design).
- ii. One and two story houses.
- iii. Different exterior materials and finishes.
- iv. Different garage location, configuration, and design.
- v. Exceptions: Other different design element that helps to distinguish one facade elevation from another as determined by the planning director.

5. Exterior Materials.

- a. Traditional materials consistent with local and regional architectural styles are encouraged (horizontal wood siding and brick).
- b. Stucco and other troweled finishes should be trimmed in masonry or wood.
- c. Mirrored glass and exposed concrete block (except for foundation/crawl space walls where not visible from the street) are not in keeping with the historic character of Eatonville and are prohibited.
- d. T-111 siding and other plywood types of siding (board and batten is an exception) shall not be used for facades adjacent to or directly viewable from a street.

6. Roof Design. Provide pitched or articulated roof line, or other roof element such as eyebrow roof forms or dormers that emphasize building form and help it to fit in with neighboring structures with prominent roofs. Pitched roofs shall utilize a minimum slope of 4:12. Encourage rooflines along the side yard that maximize solar access to adjacent homes and/or private open space.

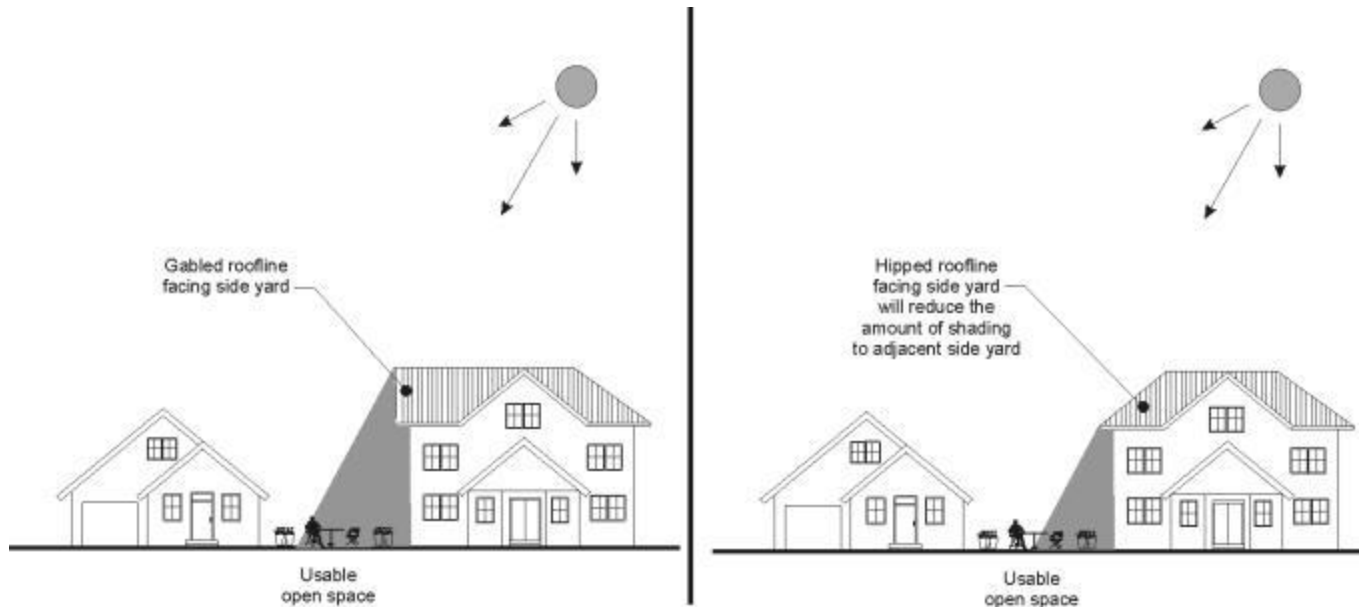

Figure 8. Encourage rooflines along the side yard that maximize solar access to adjacent homes and/or private open space.

7. Accessory Buildings. Accessory buildings (including detached garages) with more than 200 square feet of floor area shall be designed compatible with the house by using consistent materials, detailing, and roofline, as determined by the planning director.

8. Exceptions.

a. Building designs associated with proposed minor remodeling may request an exception to the building design standards. It shall be the applicant's responsibility to successfully demonstrate:

- i. If granted, how the resulting development will meet the intent of the design standards and be compatible with the existing and/or future development of the neighborhood; and
- ii. The minor remodel will cost less than \$5,000; and
- iii. The minor remodel costs are calculated at fair market value; and
- iv. Provide three complete project cost estimates (unless waived by the director); and
- v. Remodel costs associated with approved exceptions shall not exceed \$5,000 every two years. (Ord. 2018-14 § 2 (Exh. A), 2018; Ord. 2010-09 § 1, 2010).

19.04.030 Duplexes.

Duplexes should be designed similar in nature to single-family homes and shall feature a visible entry and windows facing the street. The visibility of driveways and garages shall be minimized and sufficient private open space provided. Specifically, duplexes shall comply with all detached single-family design standards in EMC [19.04.020](#) with the following exceptions and additional provisions:

- A. For sites without alleys, duplexes may include a 20-foot-wide shared driveway or two 12-foot driveways on opposite ends of the lot.
- B. Separate covered entries for each unit are required with a minimum dimension of four feet by six feet. Porches up to 200 square feet may project into the required front yard by up to six feet.
- C. Duplexes on corner lots shall place pedestrian entries on opposite streets.
- D. At least 10 percent of the street-facing facade shall be windows or other glazing (e.g., door glazing).

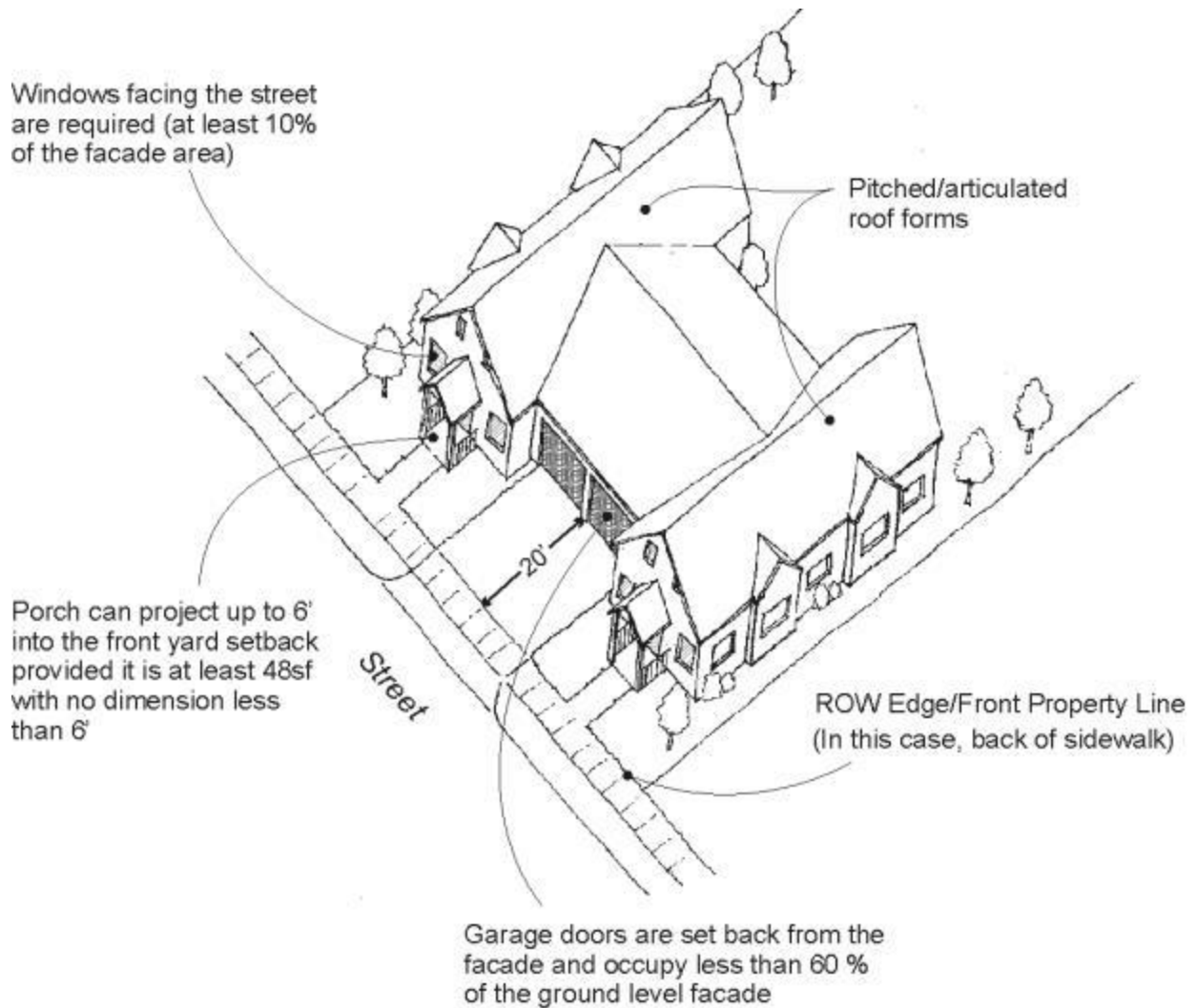

Figure 9. Duplex design standards.

(Ord. 2010-09 § 1, 2010).

Chapter 19.06 COTTAGE HOUSING STANDARDS

Sections:

- 19.06.010 Purpose.**
- 19.06.020 Generally.**
- 19.06.030 Density and dimensions.**
- 19.06.040 Dimensional standards.**
- 19.06.050 Design standards.**

19.06.010 Purpose.

The purpose of the cottage housing regulations is to:

- A. To provide for a housing type that responds to changing household sizes and ages.
- B. To provide centrally located and functional common open space that fosters a sense of community in developments.
- C. To ensure that the overall size of cottages remain smaller and incur less visual impact than regular single-family homes.
- D. To provide for a density bonus to encourage cottage housing units, particularly since they are smaller than traditional single-family homes.
- E. To minimize impacts to the natural environment.
- F. To minimize visual impact of vehicular use and storage areas on residents and streetscape.
- G. To maintain a single-family character along public streets. (Ord. 2010-12 § 7, 2010).

19.06.020 Generally.

- A. Cottage housing may be constructed only where the underlying zone allows the cottage housing as a principally permitted use or conditional use.
- B. An application for cottage housing must be submitted on the forms for conditional uses provided by the town, and in order to be complete, the application must include the following:
 - 1. A site plan and landscaping plan as specified in EMC [18.09.030\(B\)](#).
 - 2. A SEPA checklist.
- C. The cottage housing conditional use permit application shall be reviewed and processed according to the conditional use permit processing procedure set forth in EMC [18.09.030](#). The decision maker on the conditional use permit and appeals is the same as set forth in the code for conditional use permits.
- D. The criteria for approval of a cottage housing conditional use permit are as follows:
 - 1. Compliance with this chapter.
 - 2. Compliance with EMC [18.09.030\(D\)](#), Standards and Criteria for Granting.

3. Compliance with the requirements of either Chapter [17.14](#) EMC, Binding Site Plans, or Chapter [17.20](#) EMC, Preliminary Subdivision/Plats. (Ord. 2010-12 § 7, 2010).

19.06.030 Density and dimensions.

Cottage developments shall conform to density requirements of the underlying zoning district, except that in single-family zones each cottage dwelling unit shall be counted as one-half a dwelling unit for the purpose of determining allowed density on-site due to the strict size limitations of cottage dwelling units. (Ord. 2010-12 § 7, 2010).

19.06.040 Dimensional standards.

Dimensional standards for cottages are identified in Table 1 below.

**Table 1. Dimensional Standards
for Cottage Housing**

Standard	Requirement
Maximum Floor Area/Cottage	1,200 SF
Maximum Floor Area/Ground or Main Floor	800 SF (1,000 SF for single story cottages)
Minimum Common Space (see EMC 19.06.050 , Design Standards, for more info)	400 SF/unit
Minimum Private Open Space (see EMC 19.06.050 , Design Standards, for more info)	200 SF/unit
Maximum Height for Cottages	25' (all parts of the roof above 18' shall be pitched)

**Table 1. Dimensional Standards
for Cottage Housing**

Standard	Requirement
Setbacks (to exterior property lines)	Same as applicable zoning district
Minimum Distance Between Structures (including accessory structures)	10'
Maximum Height for Accessory Structures	18'
Minimum Parking Spaces per Cottage	1.5

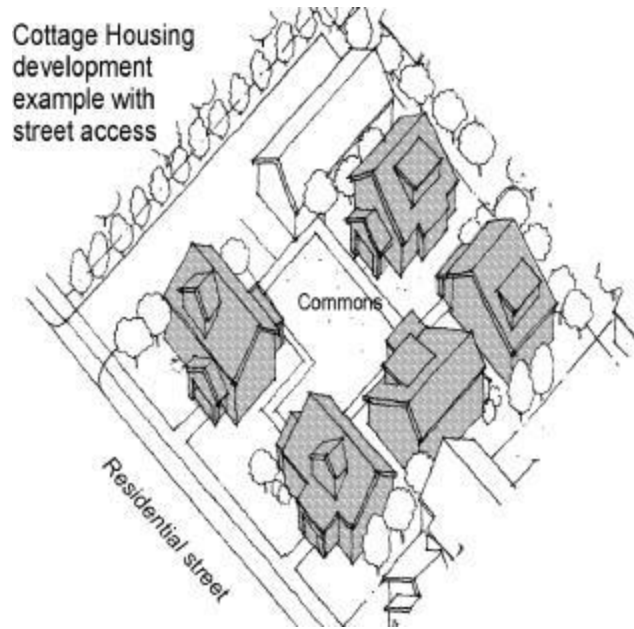



Figure 1. Cottage development examples.

(Ord. 2010-12 § 7, 2010).

19.06.050 Design standards.

A. Units in Each Cluster. Cottage housing developments shall contain a minimum of four and a maximum of 12 cottages located in a cluster to encourage a sense of community among the residents. A development site may contain more than one cottage housing development.

B. Common Open Space Requirements.

1. The common open space shall abut at least 50 percent of the cottages in a cottage housing development.
2. Cottages shall abut on at least two sides of the common open space.
3. Cottages shall be oriented around and have the main entry from the common open space.
4. Cottages shall be within 60 feet walking distance of the common open space.
5. Open space shall include at least one courtyard, plaza, garden, or other central open space, with access to all units. The minimum dimensions of this open space are 15 feet by 20 feet.

C. Required Private Open Space. Required private open space shall be adjacent to each dwelling unit, for the exclusive use of the cottage resident(s). The space shall be usable (not on a steep slope) and oriented toward the common open space as much as possible, with no dimension less than 10 feet.

D. Porches. Cottage facades facing the common open space or common pathway shall feature a roofed porch at least 80 square feet in size with a minimum dimension of eight feet on any side.

E. Covered Entry Facing Street. Cottages located adjacent to a public street shall provide a covered entry feature (with a minimum dimension of six feet by six feet) facing the street.



Figure 2. Cottage development examples. Note common open spaces and porches and semi-private open spaces oriented towards the commons.

F. Character. Cottages and accessory buildings within a particular cluster shall be designed within the same “family” of architectural styles. Example elements include:

1. Similar building/roof form and pitch;
2. Similar siding materials;

3. Similar porch detailing; and/or

4. Similar window trim.

G. Diversity. A variety of cottages within the same “family” of architectural styles shall be provided in each cottage cluster. Diversity of cottages can be achieved within a “family” of styles by:

1. Alternating porch styles (such as roof forms);

2. Alternating siding details on facades and/or roof gables; and/or

3. Different siding color.

H. Parking and Driveway Location and Design.

1. Parking shall be located on the same property as the cottage development.

2. Parking areas shall be located to the side or rear of cottage clusters and not between the street and cottages. Parking is prohibited in the front and interior setback areas.

3. Parking and vehicular areas shall be screened from public street and adjacent residential uses by landscaping or architectural screens. For parking lots adjacent to the street, at least 10 feet of Type III landscaping shall be provided between the sidewalk and the parking area. For parking lots along adjacent residential uses, at least five feet of Type I, II, or III shall be required. The planning director will consider alternative landscaping techniques provided they effectively mitigate views into the parking area from the street or adjacent residential uses and enhance the visual setting for the development.

4. Parking shall be located in clusters of not more than five adjoining uncovered spaces (except where adjacent to an alley). Exceptions will be considered by the planning director provided alternative configurations improve the visual setting for development.

5. Garages may be attached to individual cottages provided all other standards herein are met and the footprint of the ground floor, including garage, does not exceed 1,000 square feet. Such garages shall be located away from the common open spaces.

6. No more than one driveway per cottage cluster shall be permitted, except where clusters front onto more than one street. (Ord. 2010-12 § 7, 2010).