

snapmaker Dual Extrusion 3D Printing Module

QUICK START GUIDE



MAKE SOMETHING WONDERFUL



CONTENTS

04 Before You Start

13 Machine Assembly

29 3D Printing

58 Maintenance

BEFORE YOU START

1.1 Disclaimer

Make sure that anyone who uses this product knows and understands the contents of the Quick Start Guide. Failure to observe this guide may lead to personal injury, inferior results, or damage to the Snapmaker products. Snapmaker does not assume responsibility and expressly disclaims liability for any personal injury, inferior results, or damage to the product arising out of or in connection with your improper operations or failure to follow the instructions of the guide.

When using Snapmaker products, you should comply with the following requirements:

- Follow the instructions of this guide, the applicable laws and regulations, and the safety regulations in the assembly, handling, storage, use, maintenance, or disposal of this product.
- Ensure there is no infringement on any third-party intellectual property rights or violation of any applicable laws or regulations when making objects using this product.

The conditions or methods of using Snapmaker products are beyond the control of Snapmaker. For this reason, Snapmaker does not assume responsibility and expressly disclaims liability for any consequences resulting from:

- your improper methods, failure to follow the instructions of this guide or impacts of other uncertain factors when operating this product;
- your infringement on any third-party intellectual property rights or violation of any applicable laws or regulations when making objects using this product;
- personal injury, inferior results, or damage to the product arising out of or in connection with the assembly, handling, storage, use, maintenance, or disposal of this product.

All the Snapmaker filaments are compatible with this product and have been tested for safety. If you use this product with third-party filaments, Snapmaker does not assume responsibility and expressly disclaims liability for any adverse effects from the use or performance of these filaments.

This manual is provided for reference purposes only. We do not warrant the absolute accuracy or completeness of the information provided by this manual. No part of this guide may be reproduced, edited, or revised by any means without the prior written permission of Snapmaker. We reserve the right to modify or revise this manual in our sole discretion at any time without notice. You can download the most up-to-date version of this manual at our Support Center (<https://support.snapmaker.com/>): select **Snapmaker Dual Extrusion 3D Printing Module > Quick Start Guide**.

1.2 Intended Use

Snapmaker dual extrusion 3D printing modules are intended for use under the guidelines provided in this guide. When making objects using Snapmaker dual extrusion 3D printing modules (hereafter Dual Extrusion Module), users remain responsible to qualify and validate the application of the created object for its intended use, especially for applications in strictly regulated areas like medical devices and aeronautics.

1.3 Safety Information

General Safety Information

- Follow the applicable local laws and regulations in the operation and application of this product.
- Follow the instructions of the guide to use and maintain this product for safety purposes.
- Do not expose this product to rain or wet conditions.
- Minors are only allowed to use this product under adult supervision and assistance.
- Ensure that bystanders also read and understand all the safety notes of this product and keep bystanders away while operating this product for safety purposes.
- Stay alert, watch what you are doing, and pay attention to the surrounding environment when operating this product.
- Do not use this product while you are tired or under the influence of drugs, alcohol, or medication.

- Do not reach inside the product or touch the moving parts while the product is still in operation.
- Do not leave the product unattended while it is still powered on.
- Always unplug the power cable from the electrical outlet before performing maintenance or modifications.



Turn off the machine immediately and stop using this product if any of the following occurs:

- You smell burning in this product at any point.
- You see any damage to the interior components of this product.
- The machine stops working unexpectedly.
- Unusual lights, sparks, or sounds come out of this product which has never occurred previously.

3D Printing Safety Information

- Do not touch the nozzle, the print sheet, and the heated bed when the machine is printing, heating, or just finished printing.
- Use this product in combination with air purifying devices or in a well-ventilated environment, for some filaments and materials may release toxic odors or fumes when melted.
- Always check the safety data sheet of each specific filament for safety information before use. You might need to take additional safety measures when using this product with third-party filaments.

1.4 Safety Labels

Labels	Warning	Location
	Avoid contact with hot surfaces.	On the Dual Extrusion Module
	Take care to avoid crushing hands.	On the Dual Extrusion Module

1.5 Specifications^[1]

Dual Extrusion Module	
Product Model	TH-F-DUAL-AS
Dimensions	108 mm × 70 mm × 133 mm
Weight	1 kg
Frame Material	Aluminum Alloy
Input Voltage	24 V DC
Operating Temperature	15-30°C

Work Area ^[2]	<p>A150: Dual Nozzle: 135 mm × 140 mm × 110 mm Left Nozzle: 145 mm × 145 mm × 110 mm Right Nozzle: 135 mm × 140 mm × 110 mm</p> <p>A250: Dual Nozzle: 220 mm × 235 mm × 205 mm Left Nozzle / Right Nozzle: 220 mm × 235 mm × 205 mm</p> <p>A350: Dual Nozzle: 310 mm × 325 mm × 290 mm Left Nozzle / Right Nozzle: 310 mm × 330 mm × 290 mm</p>
Compatible Machine Models	Snapmaker 2.0 A150, Snapmaker 2.0 A150DET, Snapmaker 2.0 A150 Bundle, Snapmaker 2.0 A250, Snapmaker 2.0 A350, Snapmaker 2.0 A250T, Snapmaker 2.0 A350T, Snapmaker 2.0 A250ENT, Snapmaker 2.0 A350ENT, Snapmaker 2.0 A250DET, Snapmaker 2.0 A350DET, Snapmaker 2.0 F250, Snapmaker 2.0 F350, Snapmaker 2.0 F250DE, Snapmaker 2.0 F350DE
Supported Materials ^[3]	PLA, Breakaway Support for PLA, ABS, ASA, PETG, PVA, TPU95-HF, TPU95, TPU90, TPU-foam, HIPS, CoPA, PA6-CF, PA6-GF, PA12-CF

Note:

[1] The specifications listed might be slightly changed in any meaningful way when Snapmaker refines the product.

[2] Due to the installation errors generated by different users on human sensory identification, the above work area may vary from machine to machine and is for reference only.

[3] The hardened steel nozzle should be used when printing with CoPA, PA12-CF, PA6-CF and PA6-GF.

1.6 Parts List

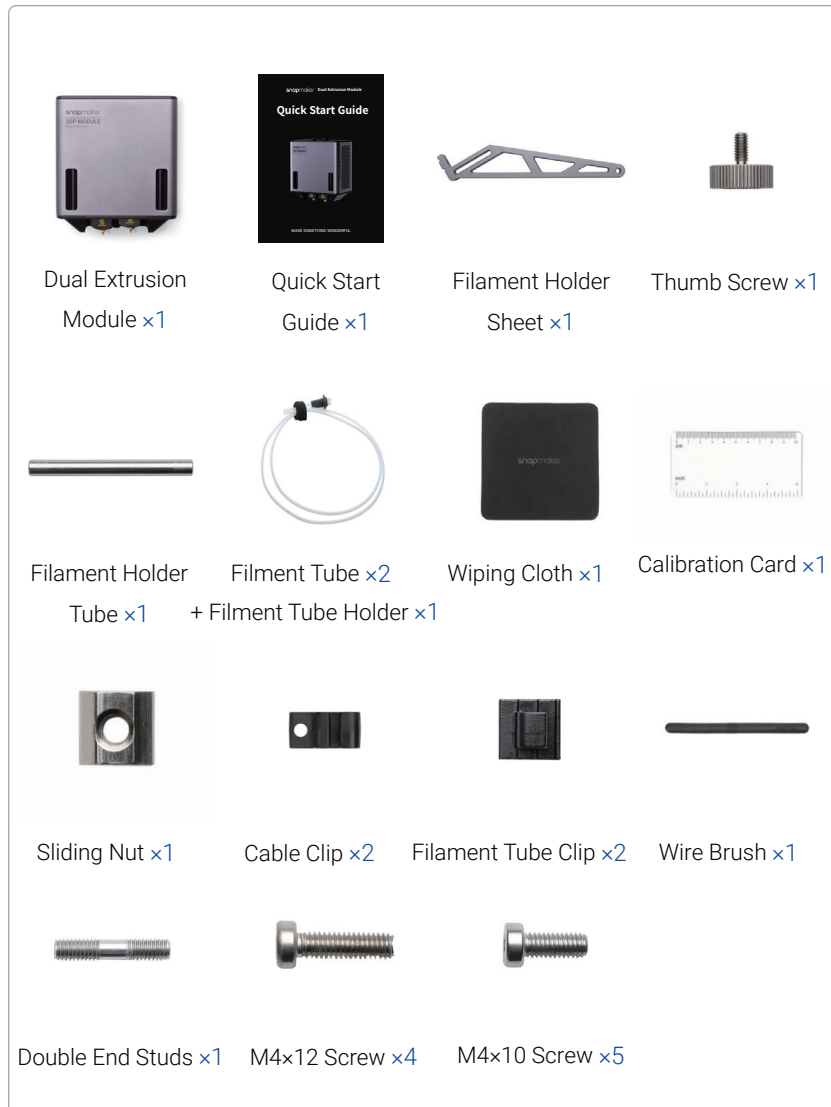



1.7 Used Symbols

-
-  **WARNING** Ignoring this type of message might result in malfunction or damage of the product and injuries to users.

 -  **CAUTION** Details you should be aware of throughout the process.

 -  **EXPLANATION** Provides supplementary information for a better understanding of the instruction.

 -  **TIPS** Tips offer you convenient operations and additional options.

 -  **ORIENTATION** Make sure that the highlighted part is facing the right way.

1.8 Preparations

1.8.1 Software Update



Download the latest version of Snapmaker Luban from <https://snapmaker.com/snapmaker-luban>. If you have already installed Snapmaker Luban on your computer, ensure that its version is 4.5.0 or later. This guide takes version 4.5.0 as a demonstration.

1.8.2 Get the Screwdriver Ready



Get the screwdriver ready. The screwdriver head H2.5 is used for assembling the machine. The other heads are used for maintenance. Before use, ensure that the screw bit holder is put back into the handle.

1.9 About this Quick Start Guide

In the chapter of Machine Assembly, to describe how to assemble the machine under the two scenarios of the machine without the Enclosure and with the Enclosure installed, this guide takes Snapmaker 2.0 A150 and A350T as a demonstration. While in the chapter of 3D Printing, all steps demonstrated on Snapmaker 2.0 A350T apply to all the other compatible machine models.

This Quick Start Guide is intended to guide you through the assembly of Dual Extrusion Module and the first-time operation with concise instructions and graphics. Only one of the workflows has been described for you to get started, for other workflows and more information about Dual Extrusion Module, refer to our online User Manual: On the navigation bar of the Snapmaker official website (<https://support.snapmaker.com/>), click **Support** > **Product Support** > **Snapmaker Dual Extrusion 3D Printing Module** > **User Manual**.

MACHINE ASSEMBLY

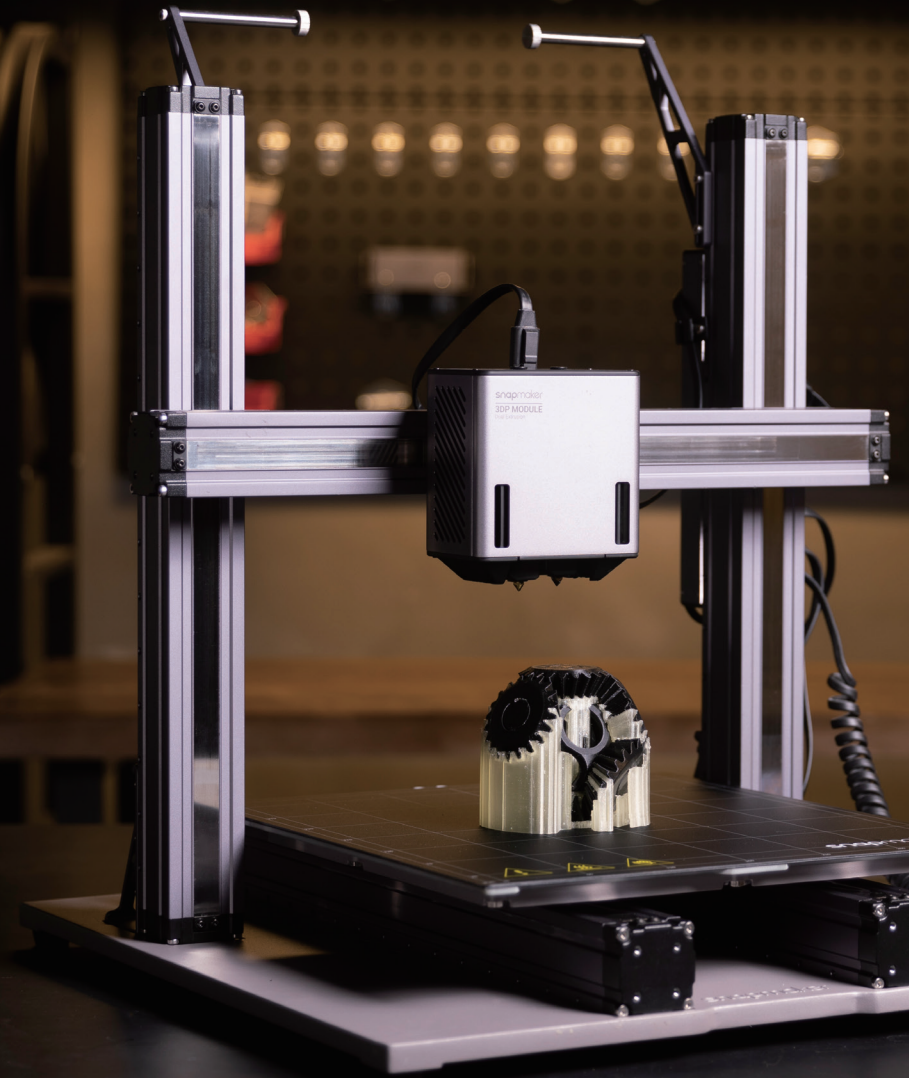

2.1 Scenario 1: Enclosure Not Installed on the Machine

If the Enclosure is not installed on your machine, follow the corresponding steps below to install the Dual Extrusion Module and the Filament Holder(s) in accordance with your machine models.

2.1.1 A150

01

_{/03}

Attach the Dual Extrusion Module to the slider on the X axis.

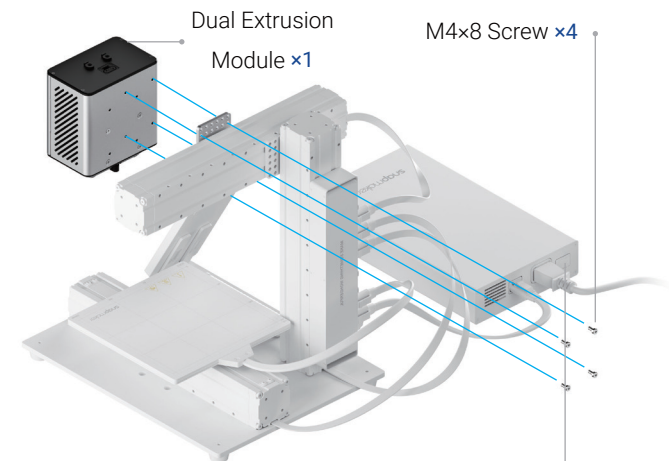
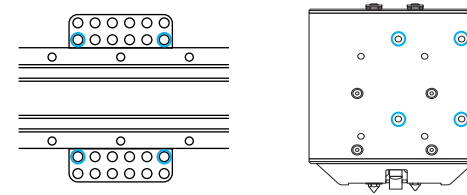

02/03

Connect the Dual Extrusion Module with the controller.



Make sure the connector is in the right direction.

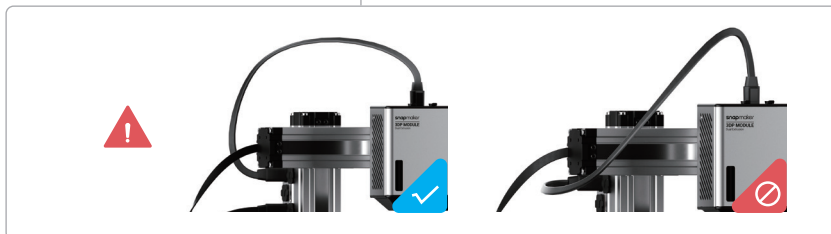
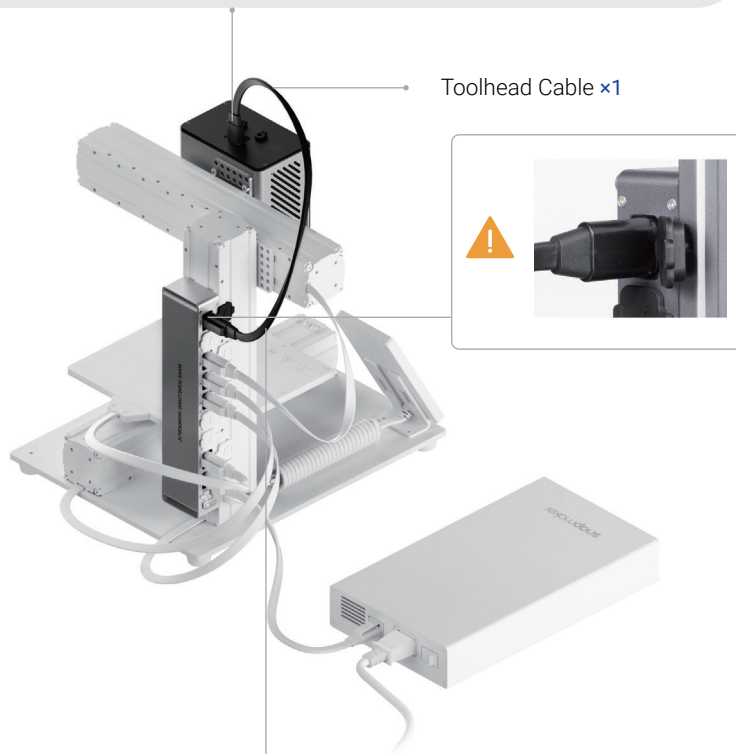

03/03

Extend the Filament Holder Tube on the basis of the original Filament Holder.

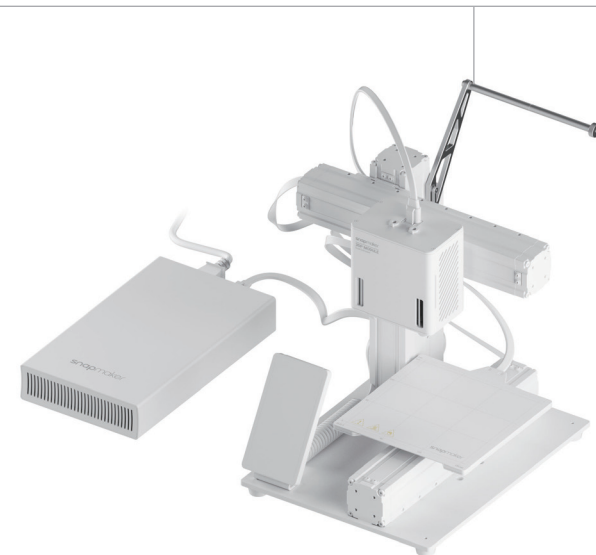
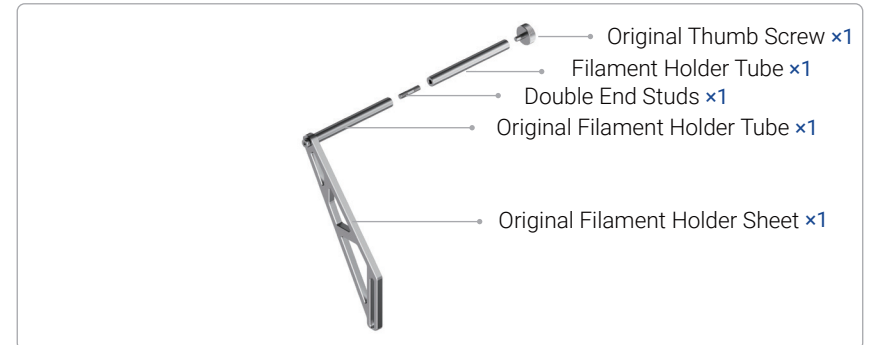

There is no need to detach the original Filament Holder Sheet already installed on the machine.

2.1.2 A250/A250T/F250/A350/A350T/F350

01/04

Attach the Dual Extrusion Module to the slider on the X axis.

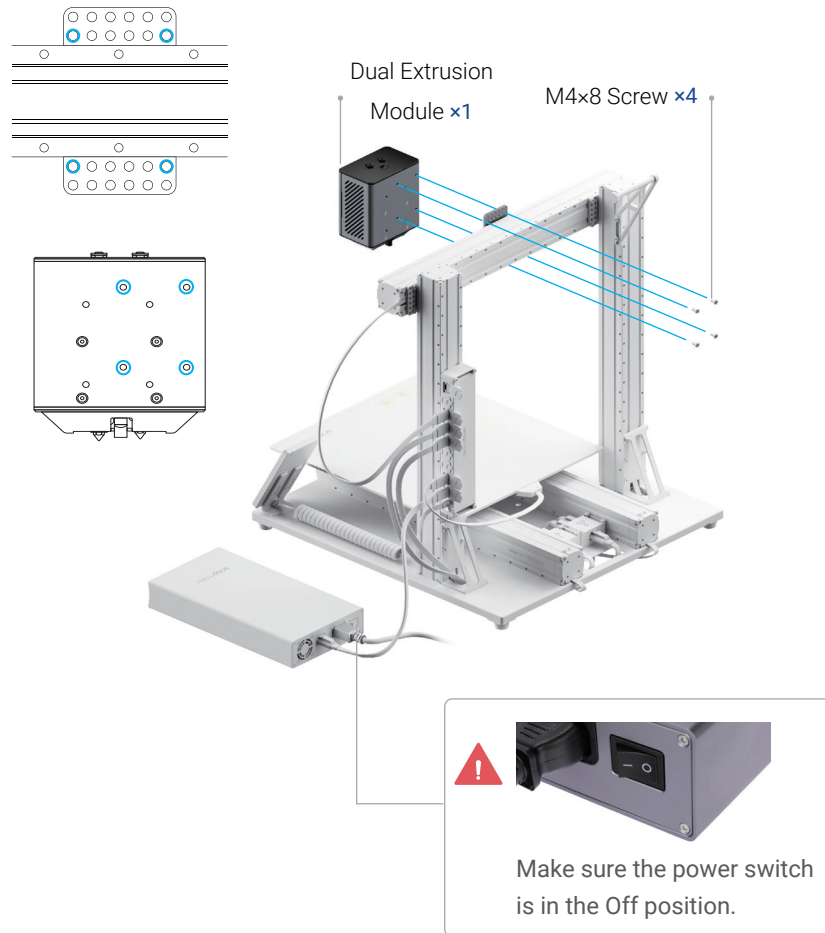

02/04

Attach the two cable clips to the X axis and the Z axis.

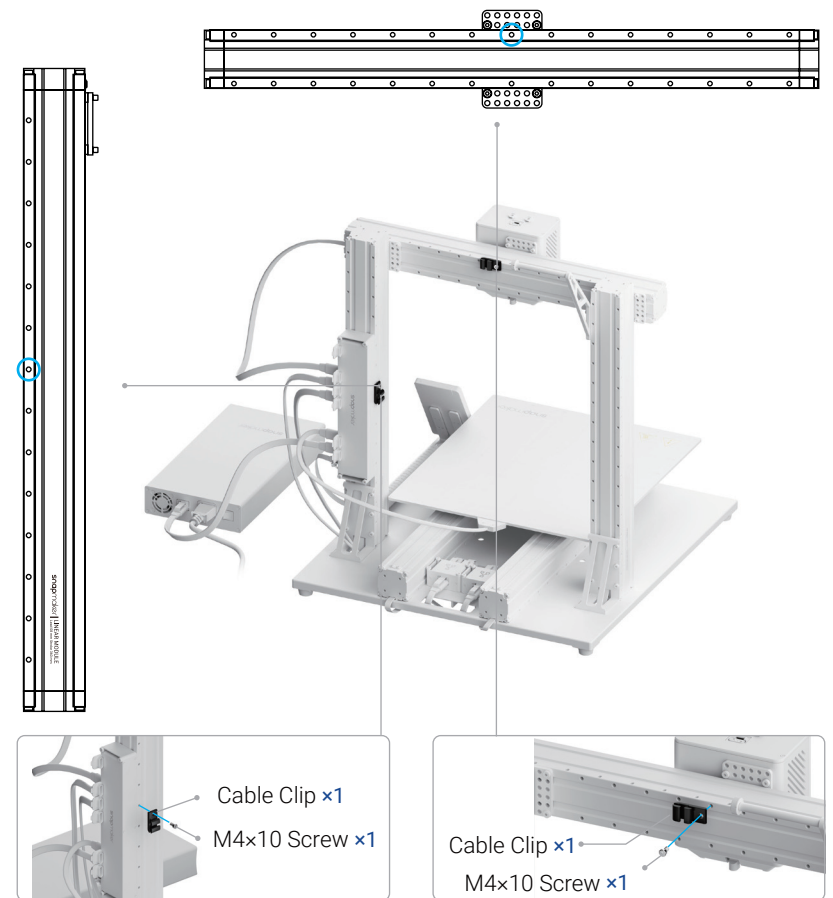

03/04

Connect the Dual Extrusion Module with the controller, and then lock the Toolhead Cable into place.

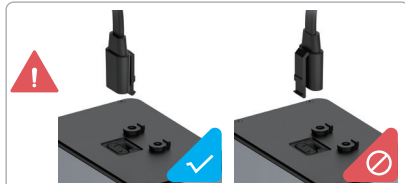

Make sure the connector is in the right direction.



Toolhead Cable ×1

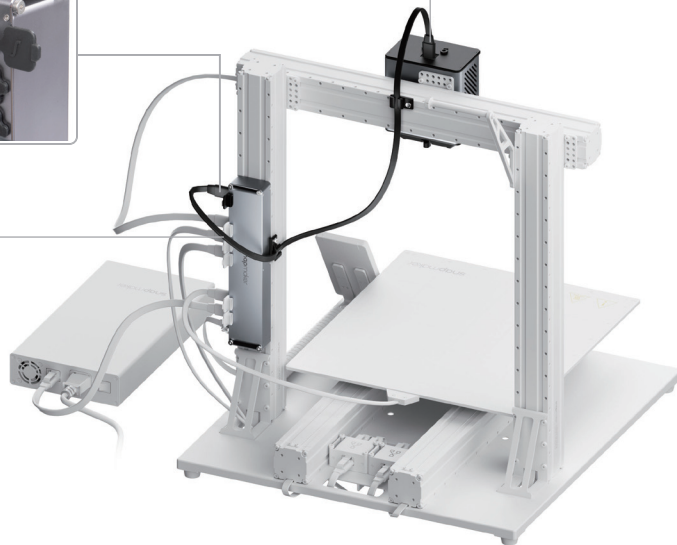

Make sure there is enough cable length for the toolhead to move.

04/04

Remove the cable clip that came with the machine, and then attach the new Filament Holder to the other Z axis.

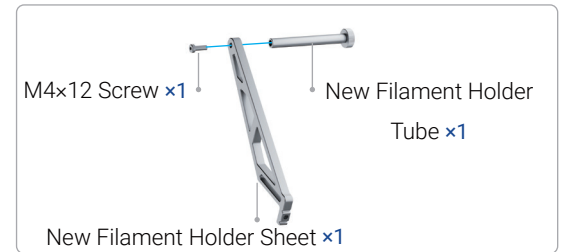

M4x10 Screw ×2

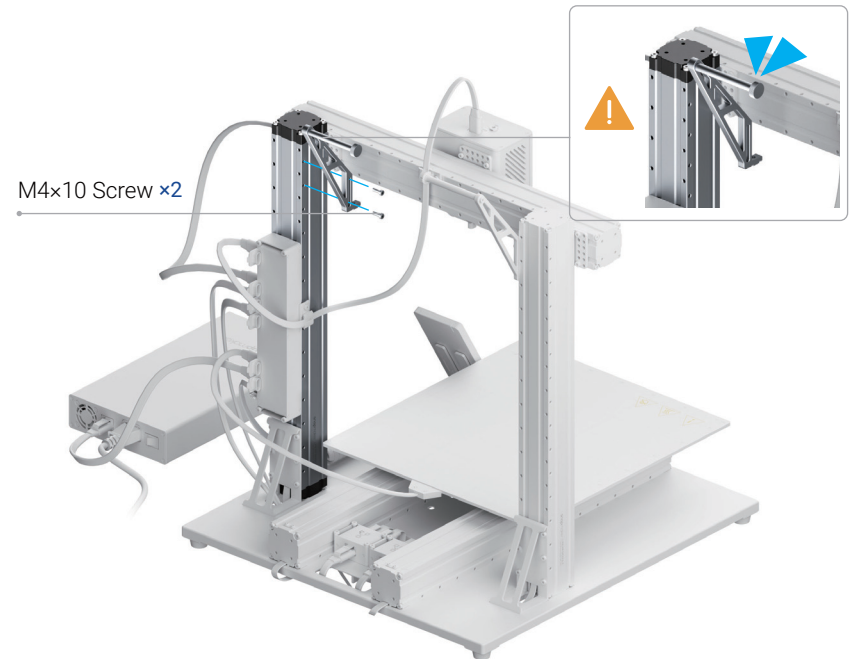

2.2 Scenario 2: Enclosure Installed on the Machine

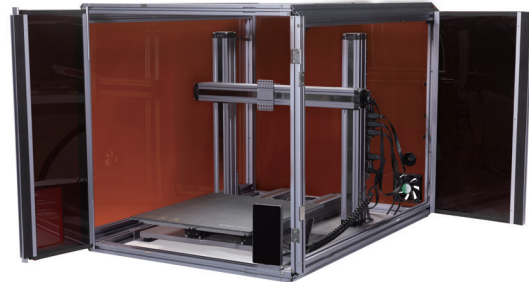
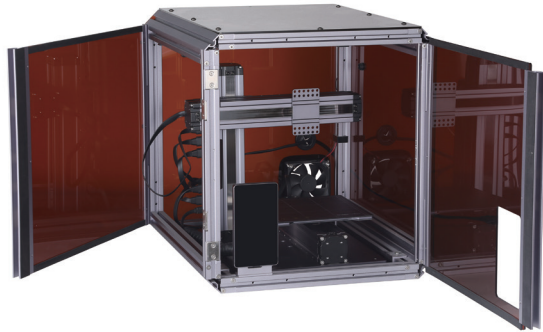

If you already have the Enclosure installed on your machine, move the toolhead and platform to proper places as illustrated above that are convenient for detaching, demonstrated in [3.2 Change Machine Functions](#) in the Quick Start Guide of the Enclosure.

Turn off the machine. Refer to Chapter 2.1 to install the Dual Extrusion Module, and then follow Steps 01-06 to install the Filament Holder and the Filament Tube Holder.

2.2.1 A150/A250/A250T/F250/A350/A350T/F350



This guide takes the Enclosure of Snapmaker A350/A350T/F350 as a demonstration to describe how to install the Filament Holder and the Filament Tube Holder. All steps demonstrated apply to the Enclosure of Snapmaker A150, A250/A250T/F250.

01/06

Detach the original Filament Holder from the Enclosure, and then install the new Filament Holder as illustrated.

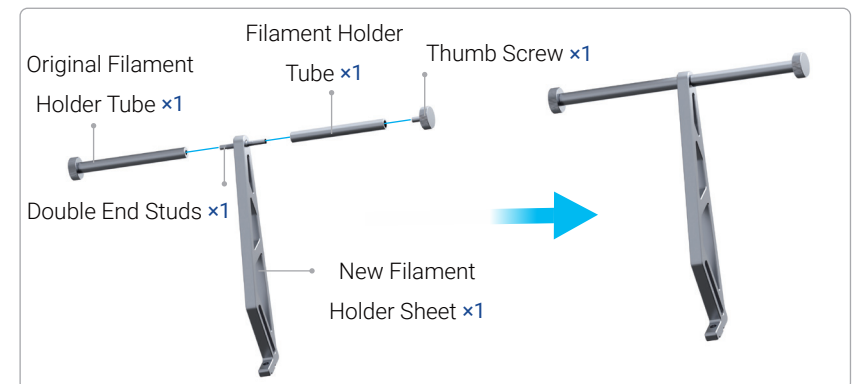

02/06

Insert the Sliding Nut into the 48CA Beam on the left of the Enclosure. Adjust the installation position of the Sliding Nut, in alignment with where the Snap Bushing is.

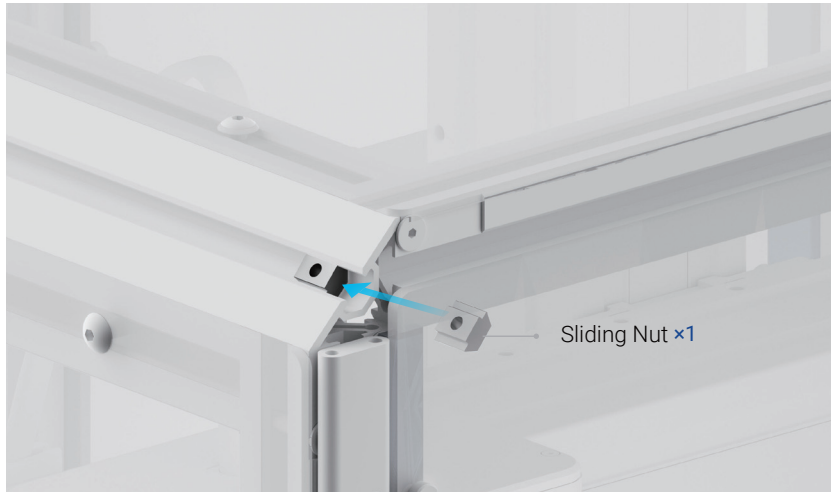
**03/06**

Attach the new Filament Holder to the Sliding Nut.



04/06

Press both sides of the Snap Bushing inside the Enclosure, and then gently push it out of the Side Panel.

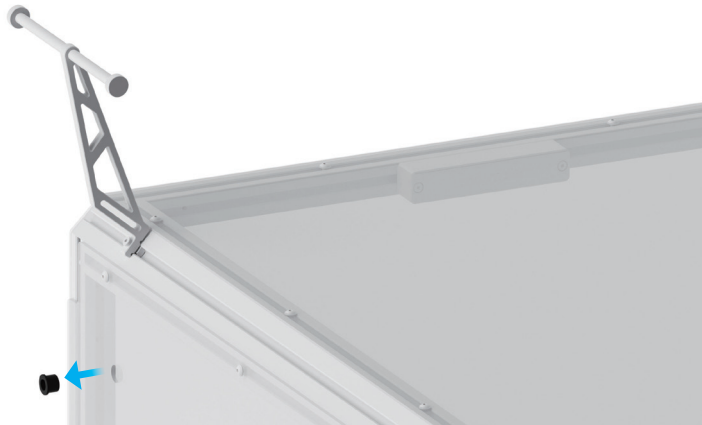
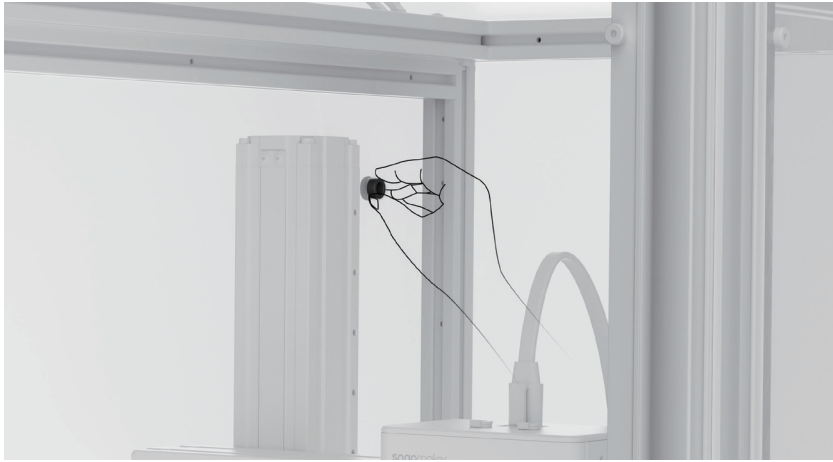
**05/06**

Mount the Filament Tube Holder and the Filament Tube onto the Side Panel.

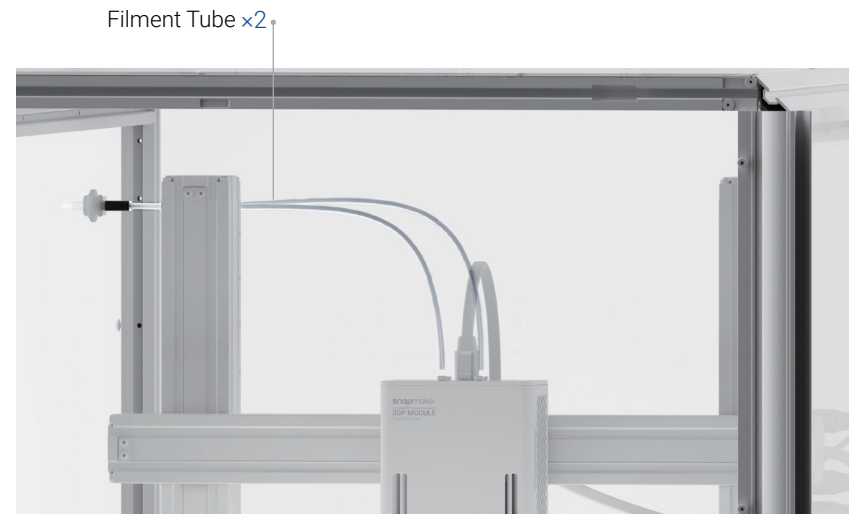

If you are using the A150 Enclosure, cut the Filament Tube as needed.

06/06

Remove the tube fixture from the filament entry, insert the Filament Tube into the module, and finally attach the tube fixture back.

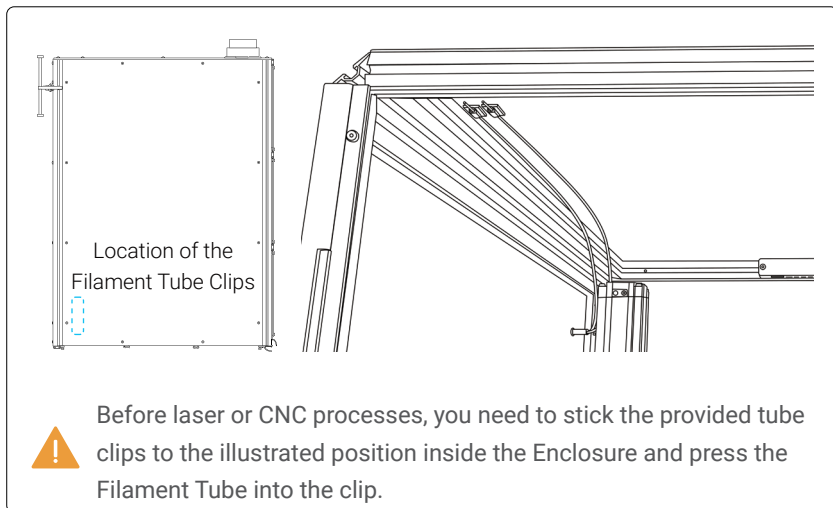

To pull out the Filament Tube from the module, remove the tube fixture first and press tight the round clamp at the filament entry while pulling.

3D Printing

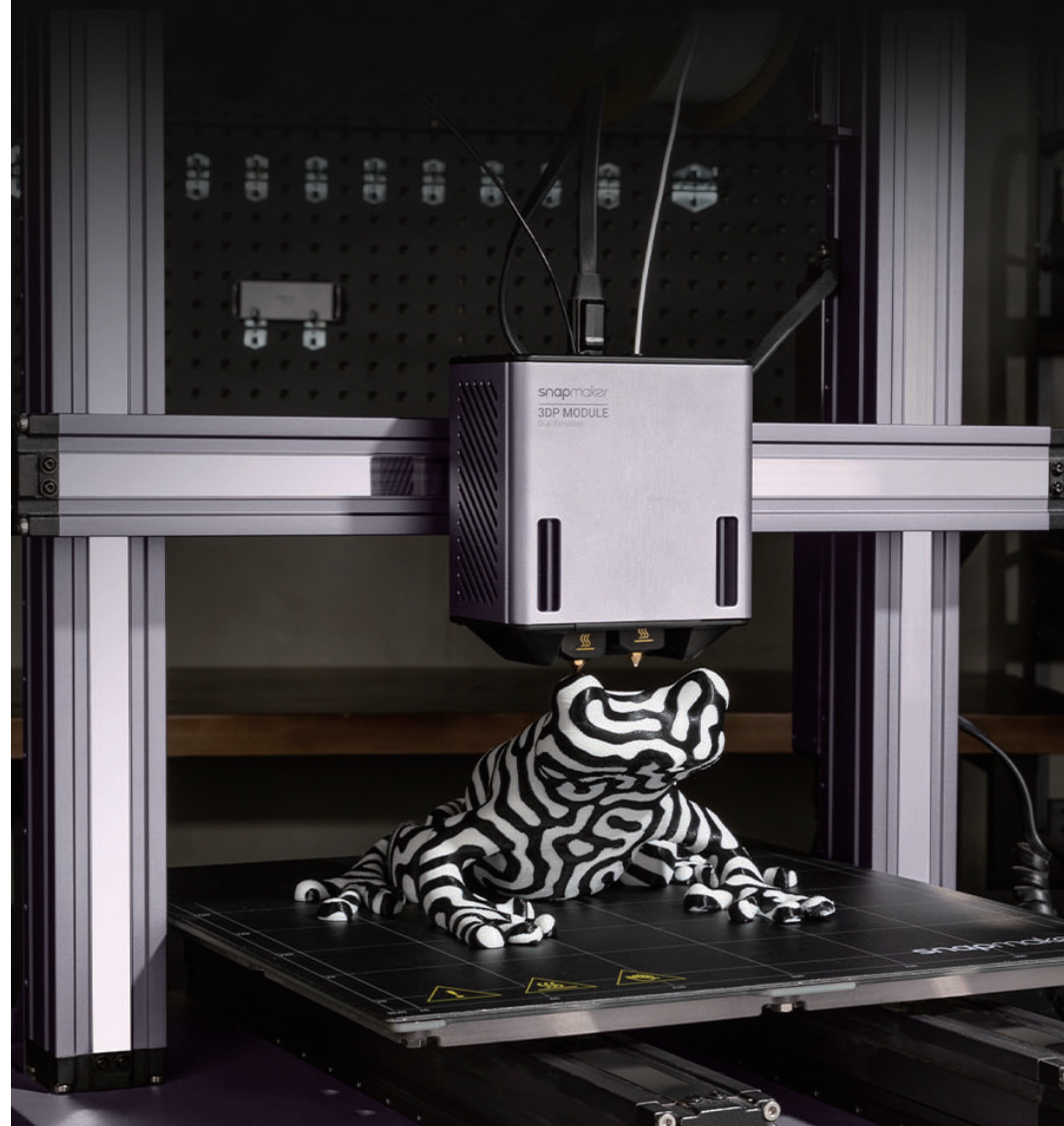

3.1 Firmware Update

Before use, update the firmware to version 1.15.0 or later. For Touchscreen installed with the firmware of V1.9.0 or later, you can update via Wi-Fi or USB flash drive. For firmware previous to V1.9.0, update only via USB flash drive.

: Turn on the machine > connect your machine to a Wi-Fi network > swipe left on the Touchscreen > tap **Settings** > **Firmware Update** > **Check for Updates** > **Update Now** > **Complete**.

: Download our firmware from <https://support.snapmaker.com> > insert the USB flash drive into the controller > turn on the machine > swipe left on the Touchscreen > tap **Files** > tap **USB** > tap the firmware file to update.

3.2 Read Safety Notes

Turn on the machine. Read the Safety Notes, and then tap **Confirm**, the machine will automatically enter the Guide process.

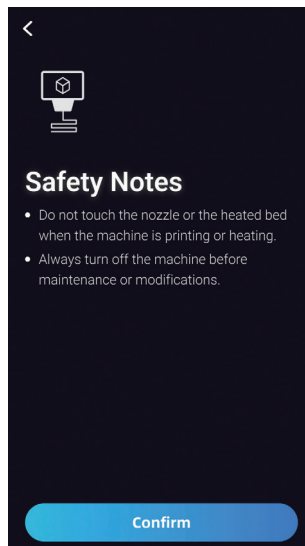

3.3 Calibrate the Dual Extrusion Module

For the first-time use of the 3D printing function, the Touchscreen will walk you through the necessary calibration processes so that the Dual Extrusion Module can work properly.

You will have to complete three processes following the calibration wizard: Leveling & Z Offset Calibration, XY Offset Calibration, and Offset Calibration Check. Before you start the calibration, we recommend that you read this section to learn about each process.

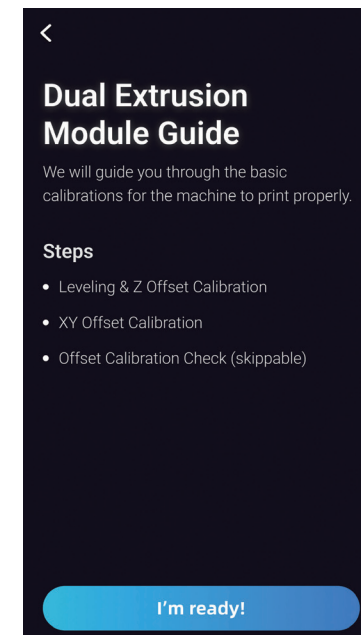

This calibration wizard appears only the first time you use the Dual Extrusion Module. To redo the calibrations later, swipe left on the homepage of the Touchscreen > select **Settings** > **Dual Extrusion Module Guide**.

3.3.1 Leveling & Z Offset Calibration

Brief Introduction

The Dual Extrusion Module features a smart sensor that can be used to automatically level the build plate and adjust the distance between the two nozzles and the build plate. In this way, the machine ensures both nozzles always extrude at a proper and consistent height throughout the printing process to avoid poor first-layer adhesion, build plate abrasion, and collision.

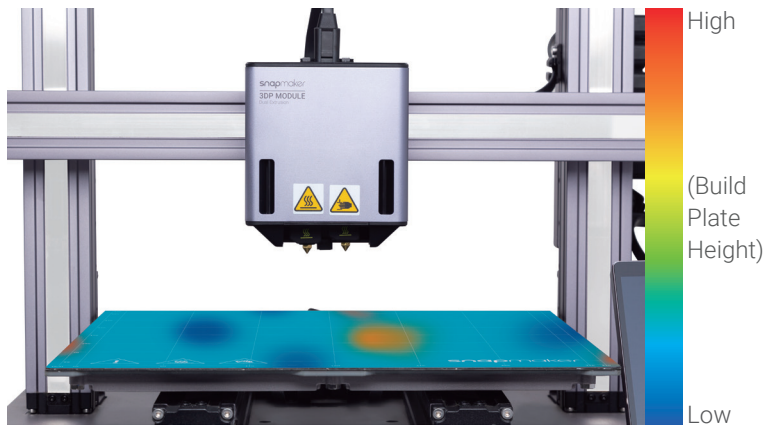

How It Works

In the Z Offset Calibration, the two nozzles will move in turn to obtain the Z-axis height of the module when the nozzle just touches the build plate. Along with the flatness data collected in the Leveling process, the machine will make real-time compensation for the build plate undulations by adjusting the Z-axis movements of the module during printing.

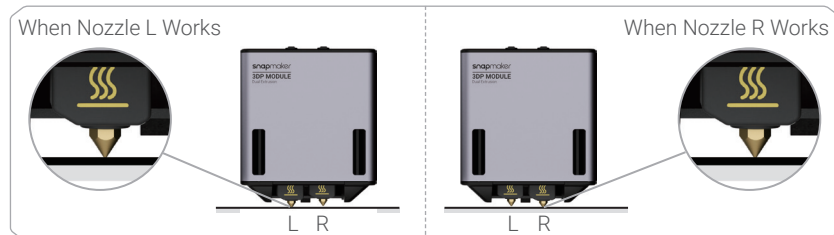

1. Tap **Start**, and the machine will run the Heated Leveling in Auto Mode by default.

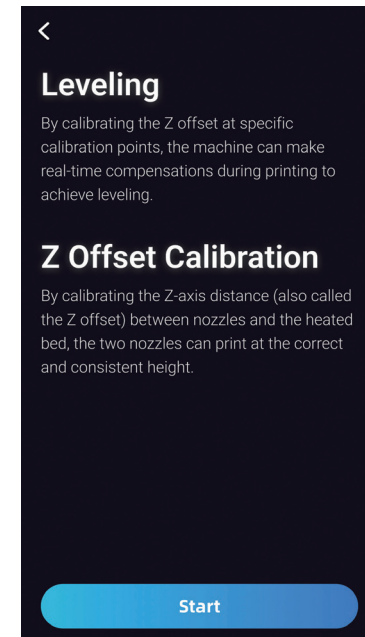

In Heated Leveling mode, to simulate realistic print conditions for better leveling results, the Heated Bed will be heated to the target temperature before performing leveling.



Before doing the Leveling and the Z Offset Calibration, ensure that the surface of both the print sheet and the nozzles is clean.

2. Tap **Got it** to start heating. After the temperature of the Heated Bed reaches the target temperature, tap **Start Leveling**.

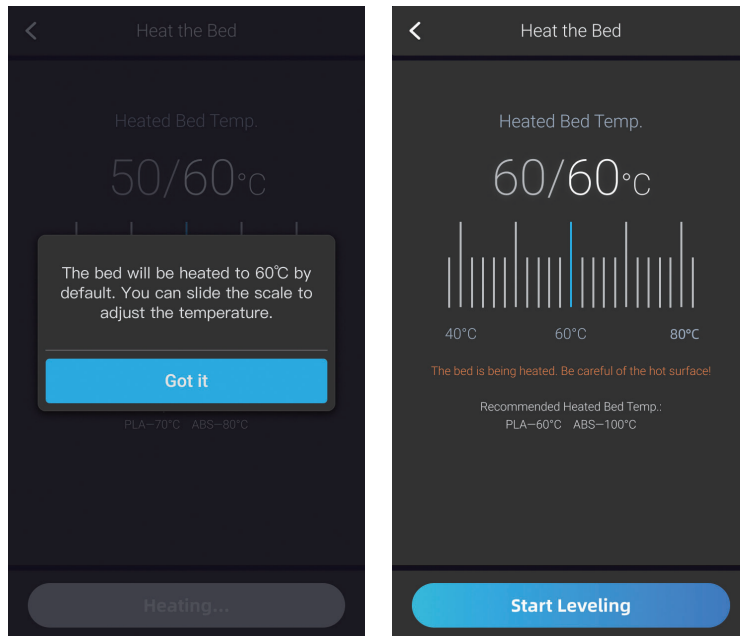

3. Wait for the machine to finish Leveling, and then it will automatically enter the Z Offset Calibration process.

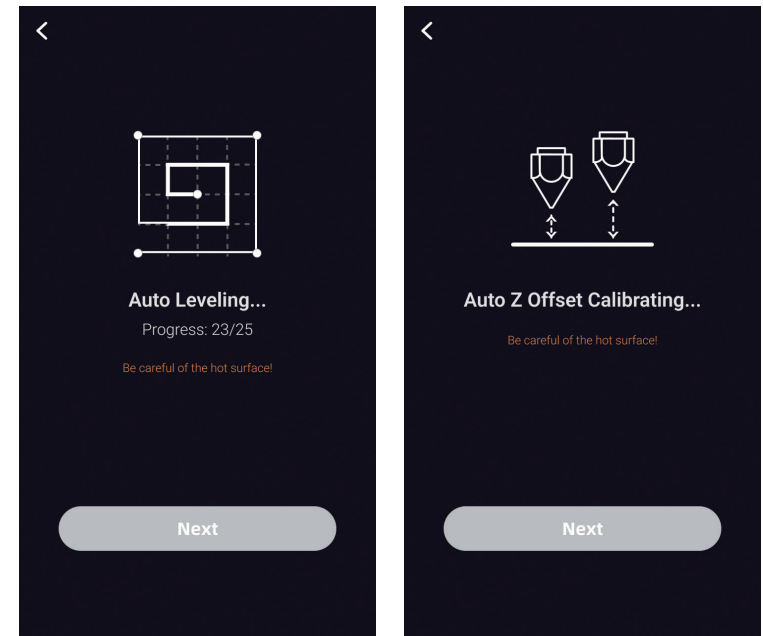

Do NOT touch the Heated Bed with bare hands while using the Heated Leveling mode.



Every time after you have reassembled the module or machine, redo the Leveling and Z Offset Calibration: swipe left on the Home Screen > tap **Calibration** > **Leveling** or **Z Offset Calibration**.

Every time after you have replaced the hot end, redo the XY Offset Calibration and Z Offset Calibration.

4. After finishing the Z Offset Calibration, tap **Next** to enter the XY Offset Calibration process.



3.3.2 XY Offset Calibration

Brief Introduction

Calibrating the offsets of the two nozzles in the X and Y orientations can achieve the optimal print quality of both nozzles in the horizontal direction and avoid crossovers between different colors and materials.

Load Filament

You need to load filaments before calibrating the X and Y offset. Tap **Start**, and the Touchscreen will guide you through loading filaments into the two nozzles.

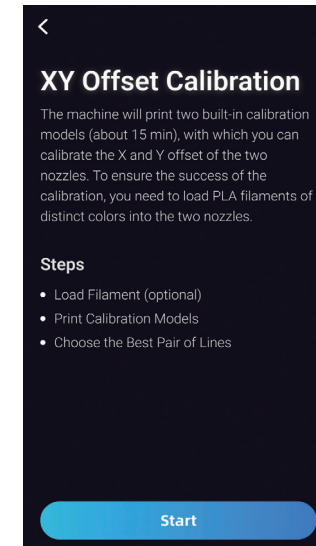

How It Works

The filament is fed into the module via the filament entry, passed by the extruder to the hot end, and extruded out of the nozzle after being heated. Our Dual Extrusion Module adopts the design of the dual-gear extruder, which features better extruding force, achieves stable and smooth loading and unloading, and can effectively avoid filament break and nozzle jam.



Load Filament Without the Enclosure Installed

1. Hang the filaments onto the Filament Holders in the order of "black filament on the left and white filament on the right", and cut the bending end of the filaments using the diagonal pliers.

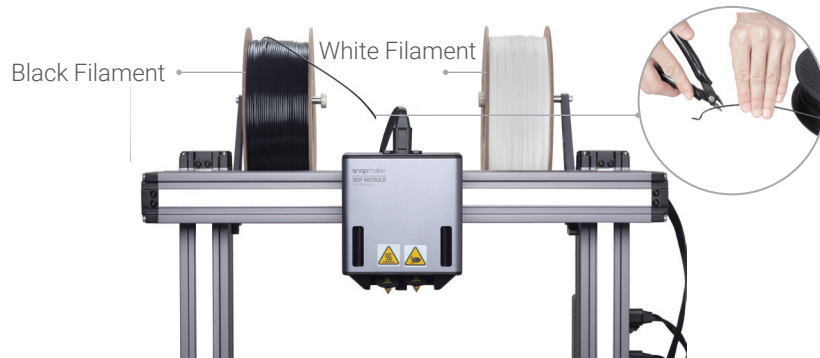

To ensure the success of the calibration, you need to load PLA filaments of distinct colors into the two nozzles.

2. Tap **Load Filament** and follow the prompts on the Touchscreen to heat the nozzles.

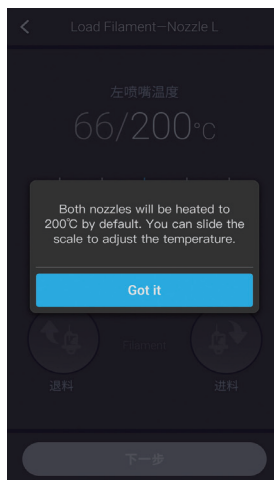

3. When the heating completes, tap **Load** and then insert the black PLA filament into the left nozzle. Tap **Stop Loading** when the filament extrudes successfully.

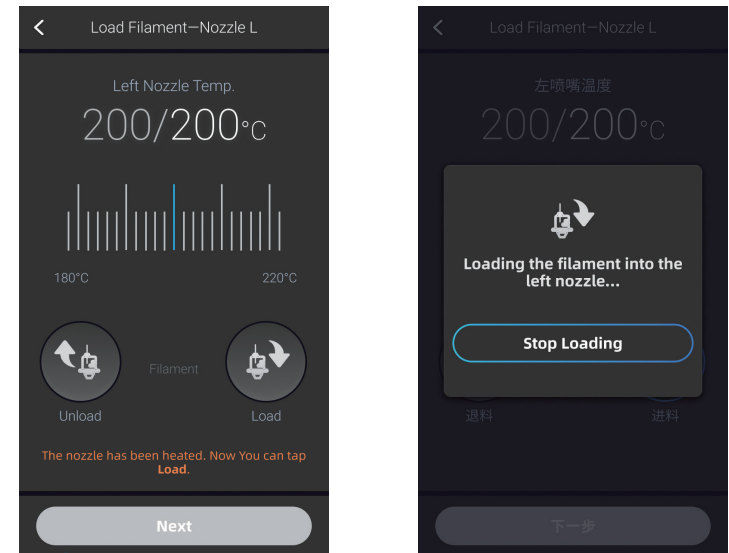

Make sure to load the black PLA filament into the left nozzle and the white PLA filament into the right nozzle, which is required to print the test model.

4. Tap the Touchscreen and shift to the right nozzle, and repeat Step 3 to load the white PLA filament into the right nozzle.

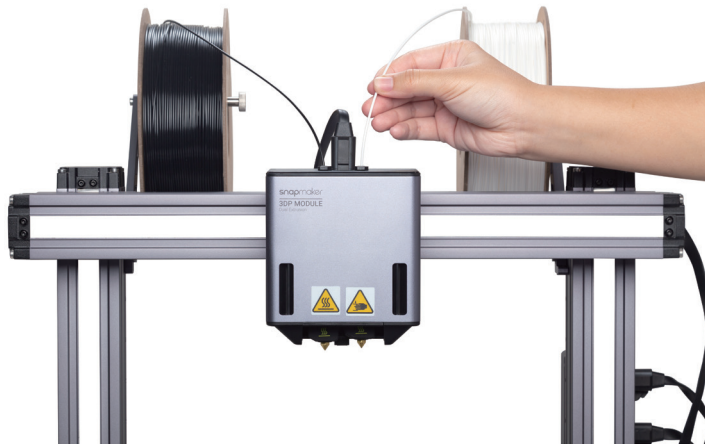

Do NOT touch the nozzle with bare hands during the filament loading process, as the nozzle will be heated to an extremely high temperature.

5. Clean the nozzles using the tweezers, go back to the page before loading and tap **Start**.

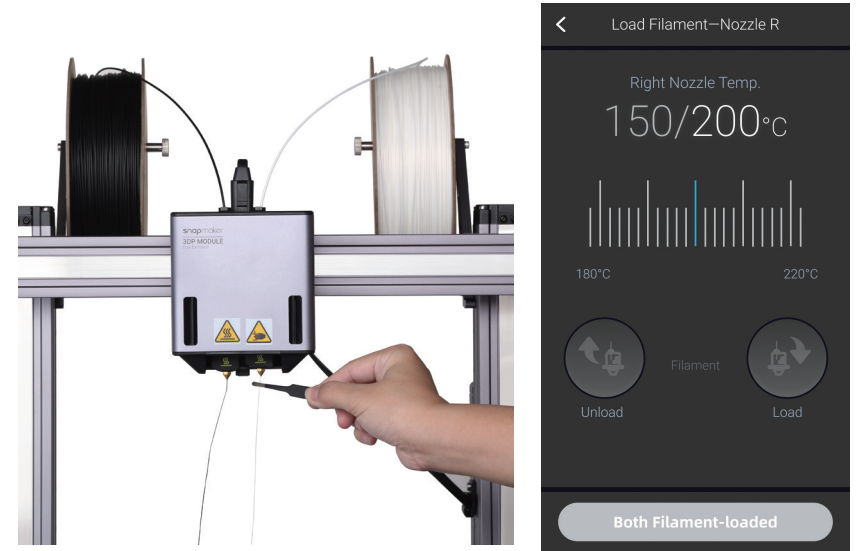

If no filaments are coming out of the nozzles, do not exit the page until you repeat the steps above and the filaments extrude successfully.



To change the filament, take the following steps:

1. Tap **Control** > **Nozzle** on the Home Screen.
2. Select the target nozzle, set the temperature, and tap **Heat**.
3. When the heating completes, tap **Unload** and pull the filament out of the nozzle.
4. Insert the new filament into the module, and tap **Load** until the new filament extrudes successfully.

Load Filament with the Enclosure Installed

1. Hang the filaments onto the Filament Holders, and cut the bending end of the filaments using the diagonal pliers.

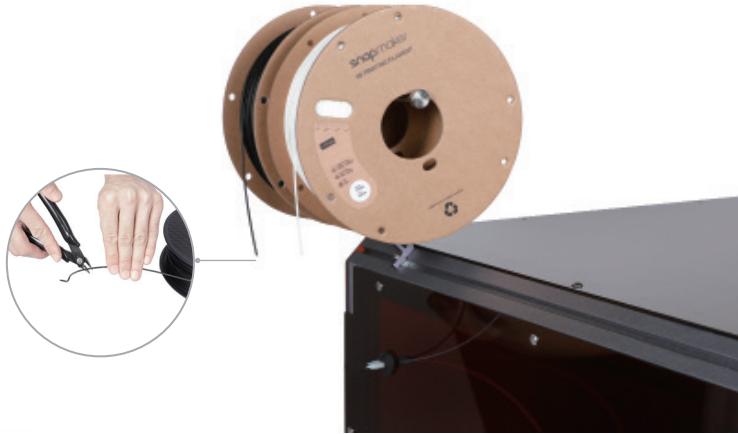

To ensure the success of the calibration, you need to load PLA filaments of distinct colors into the two nozzles.

2. Insert the filaments into the Filament Tubes in the order of "black filament on the left and white filament on the right", and push the filament close to the filament entry.

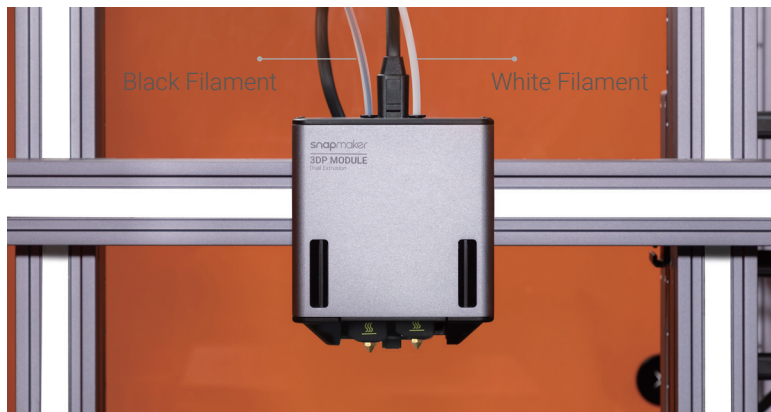

Make sure to load the black PLA filament into the left nozzle and the white PLA filament into the right nozzle, which is required to print the test model.

3. Tap **Load Filament** and follow the prompts on the Touchscreen to heat the nozzles.

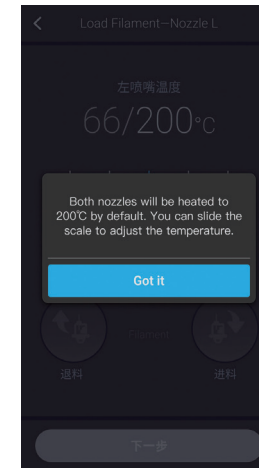

4. When the heating completes, tap **Load** and then insert the black PLA filament into the left nozzle. Tap **Stop Loading** when the filament extrudes successfully.



5. Tap the Touchscreen and shift to the right nozzle, and repeat Step 4 to load the white PLA filament into the right nozzle.

6. Clean the nozzles using the tweezers, go back to the page before loading and tap **Start**.

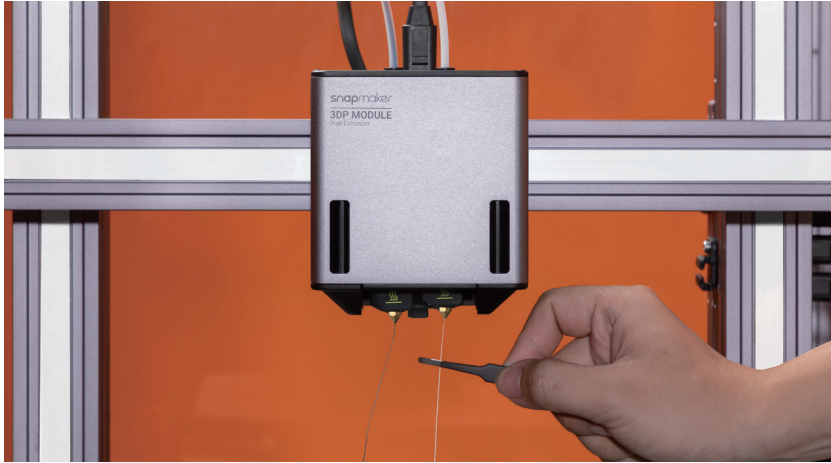

If no filaments are coming out of the nozzles, do not exit the page until you repeat the steps above and the filaments extrude successfully.



To change the filament, take the following steps:

1. Tap **Control** > **Nozzle** on the Home Screen.
2. Select the target nozzle, set the temperature, and tap **Heat**.
3. When the heating completes, tap **Unload** and pull the filament out of the nozzle.
4. Insert the new filament into the module, and tap **Load** until the new filament extrudes successfully.

How It Works: XY Offset Calibration

The machine will print a calibration model in the X and Y orientations, respectively. After you have selected the best pair of lines (where the top line is most horizontally centered on the bottom line) in the two models, the machine will automatically calibrate the X and Y offsets of the two nozzles accordingly by making real-time compensation.

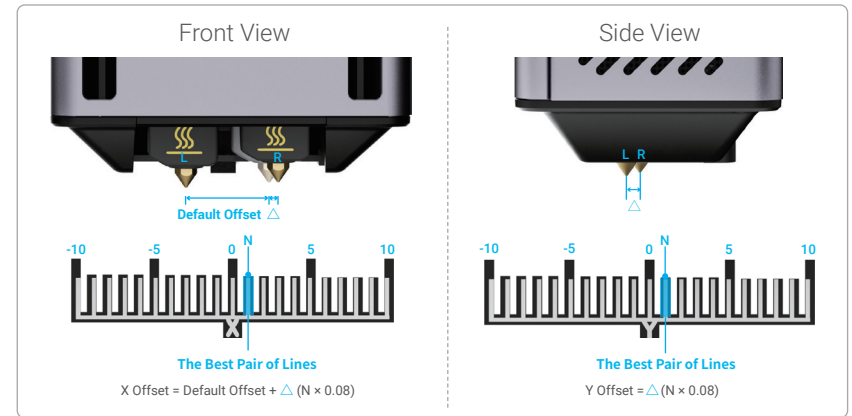

* The XY offsets and the best pair of lines in the graphics above are just examples for better illustration.



Before doing the XY Offset Calibration, ensure that the Print Sheet is clean.



Every time after you have replaced the hot end, you need to redo the XY Offset Calibration and Z Offset Calibration: swipe left on the Home Screen > tap **Calibration** > **XY Offset Calibration** or **Z Offset Calibration**.

1. When the filament loading completes, the machine will automatically print the calibration models.

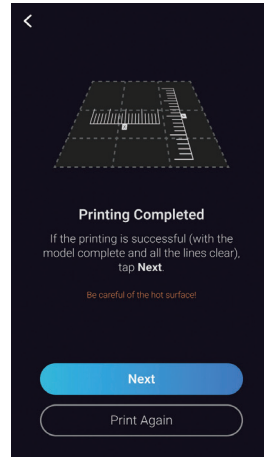
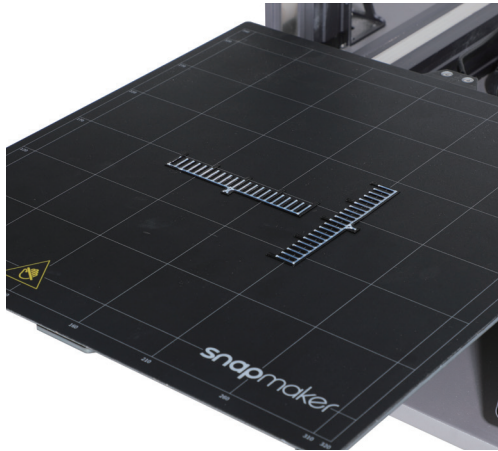

3. Slide to choose the best pair of lines.

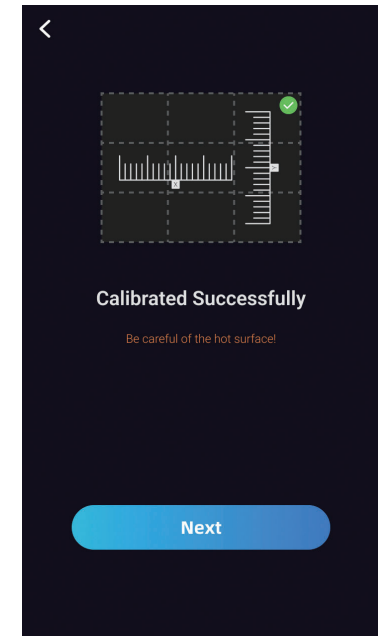
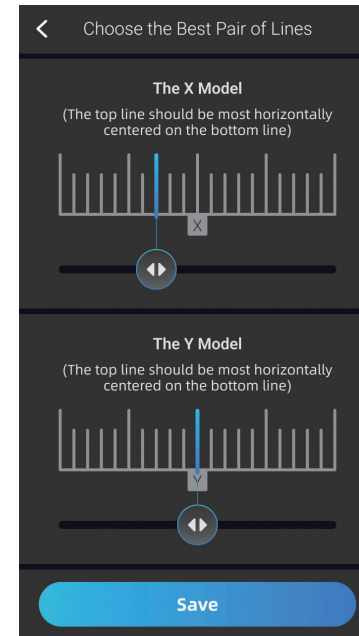

If the printing is unsuccessful, clean the Print Sheet. Now you can either tap **Print Again**, or return to **Calibration** and redo the **Leveling** and **Z Offset Calibration**. Then, try printing the calibration models again.

2. Follow the prompts on the Touchscreen to find the best pair of lines.

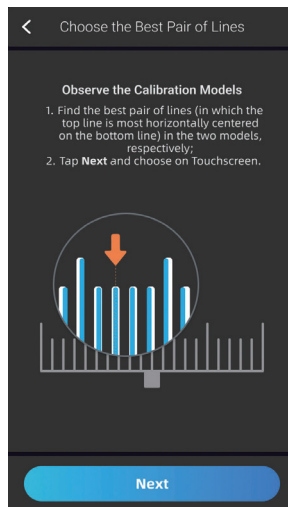

3.3.3 Offset Calibration Check

After the Leveling, Z Offset Calibration and XY Offset Calibration completes, you can print a built-in model to check if the offset calibrations are successful.

1. Tap **Start** to start printing. After the printing completes, remove the print from the Print Sheet.

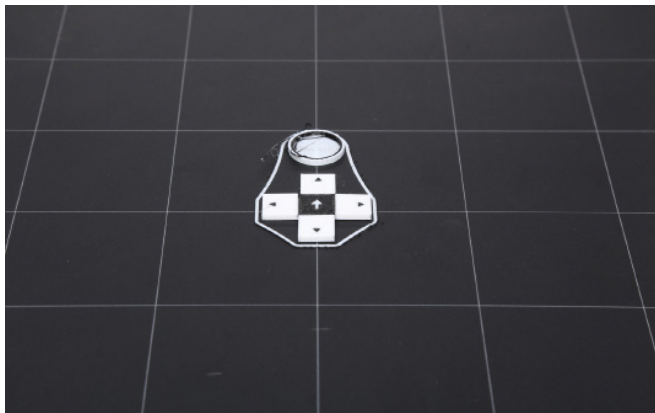
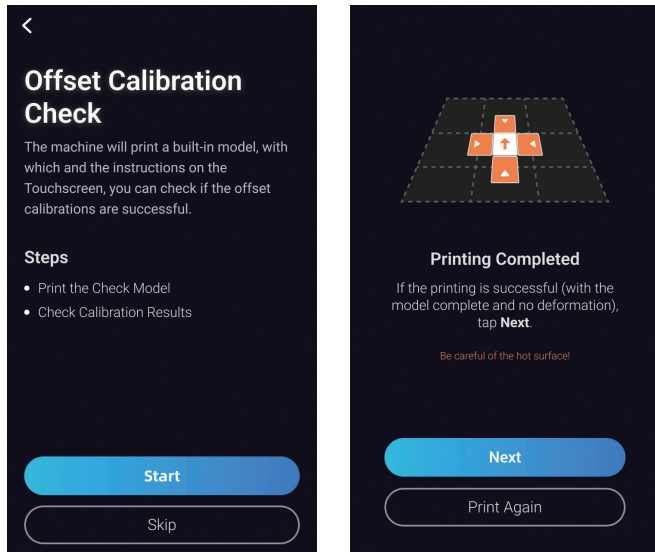

2. Follow the prompts on the Touchscreen to check the Z Offset Calibration results.

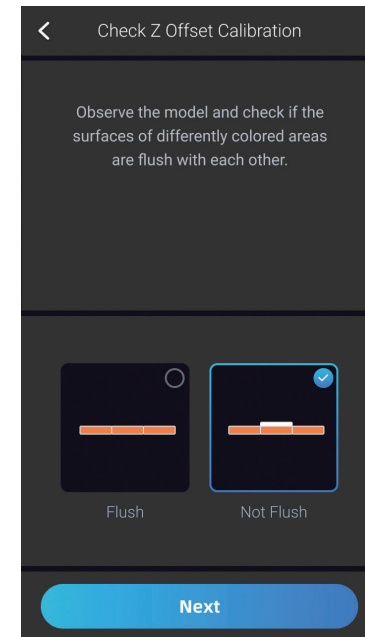

If the printing is unsuccessful, clean the Print Sheet. Now you can either tap **Print Again**, or return to **Calibration** and redo the **Leveling**, **Z Offset Calibration** and **XY Offset Calibration**. Then, try printing the calibration models again.

3. Follow the prompts on the Touchscreen to check the XY Offset Calibration results.

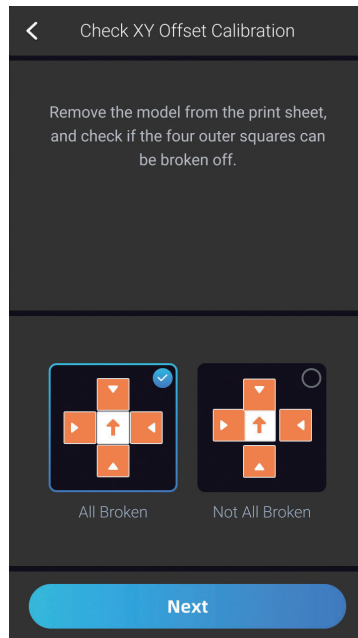

4. If all the offset calibrations are successful, tap **Complete** and now you can start printing. If not, the calibration failed will be marked with a red dot. Tap **Complete** and return to **Calibration**, redo the Z Offset Calibration or XY Offset Calibration.

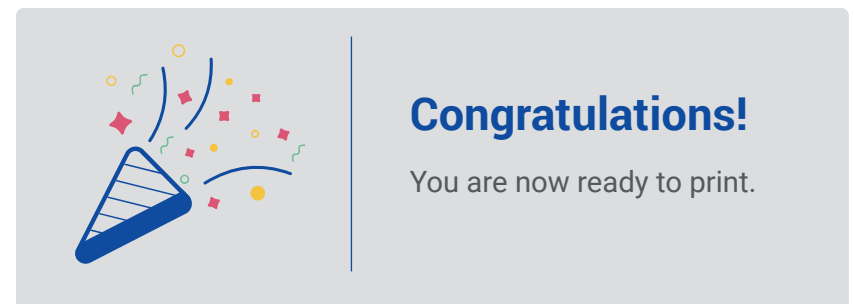
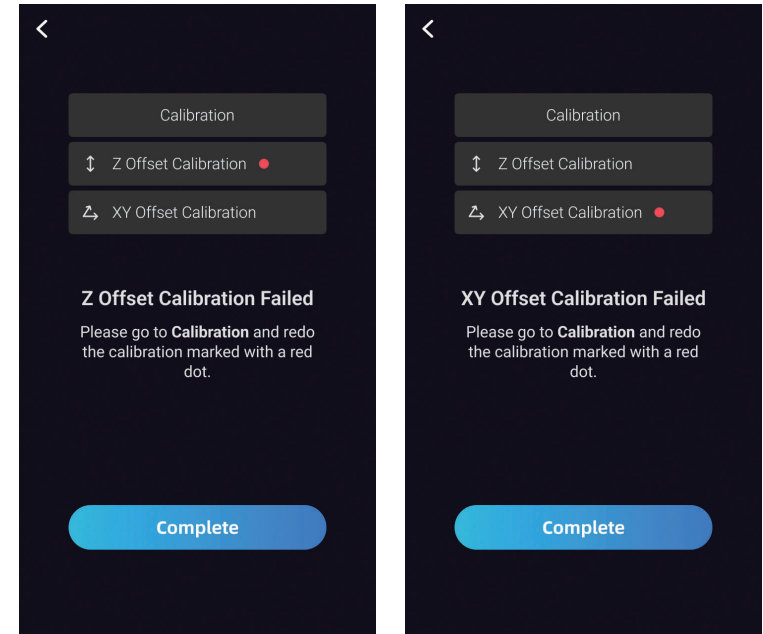



3.4 Getting Started

3.4.1 Generate the G-code File

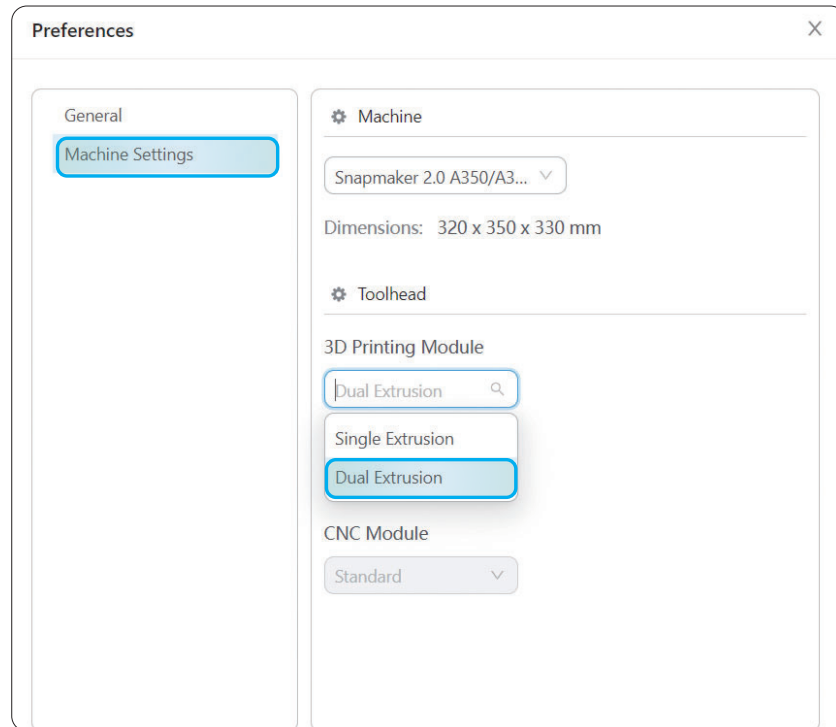
1. Launch Snapmaker Luban, click **Settings** > **Preferences** in the menu bar to select the machine model and module type.



2. Ensure that your computer and machine are connected to the same Wi-Fi network, and take the following steps to connect Snapmaker Luban with your machine:

- On the Home page of Snapmaker Luban, click  to enter **Workspace**;
- On the **Connection** panel at the top left corner, click **Wi-Fi**;
- Click , select your machine from the drop-down list, and click **Connect**;
- Tap **Yes** on the Touchscreen to allow the connection.

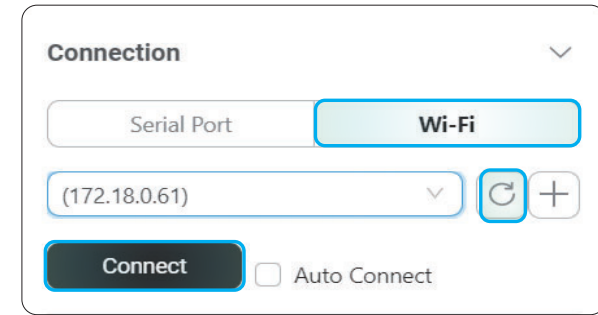

You can also connect Snapmaker Luban with your machine via the USB cable.

3. At the top-left corner of **Workspace**, click **Back** to return to the Home page. Then, click **3D Printing** to enter the **3D Printing G-code Generator**.

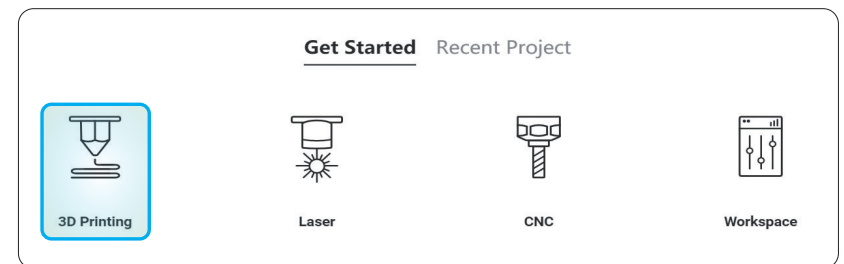

4. Follow the Beginner's Guide to get familiar with the basic operations. During this process, Luban will automatically load the test model and configure the parameters.



If the Beginner's Guide does not pop up or quits unexpectedly, you can click **Help > Beginner's Guide** in the menu bar.



You can also click  to import your own files and configure the parameters.

5. Generate the G-code file, and then click **Export > Load G-code to Workspace** at the bottom-right corner.

3.4.2 Start Your First Print

1. In the **Preview** window, click **Start Job > Start on Luban** to create your first print! If the Wi-Fi network is unstable or disconnected during the printing, the ongoing printing process will not be affected.

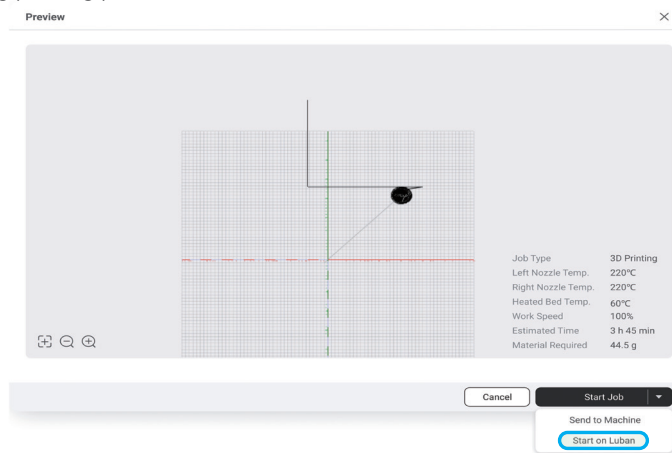

Keep the front cover of the Dual Extrusion Module closed throughout the printing process.



You can also send the G-code file to your machine at **Workspace** or via the USB flash drive.



After the printing starts, you need to pay close attention to the first layer adhesion to detect any problems in time to avoid wasting filaments. In case of poor adhesion, you can try the following solutions:

Solution 1: Adjust the Z Offset during printing to slightly reduce the distance between the nozzle and the build plate. However, please note that the nozzle may fail to extrude successfully or even damage the build plate and itself if too close to the build plate.

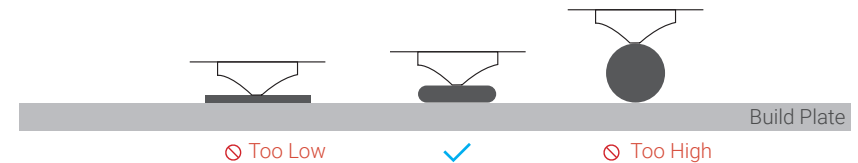

Solution 2: Stop the current printing and remove the print from the Print Sheet. Then, swipe left on the Home Screen, tap **Calibration** and redo the Leveling and Z Offset Calibration. The machine will run the calibration processes in Auto Mode by default.

If the calibration results remain unsatisfactory, you can try the following operations:

- Heated Bed Leveling: Switch to Manual Leveling, increase the calibration points or the bed temperature, and then redo the calibration.
- Z Offset Calibration: Select a different mode, and then redo the calibration.

Solution 3: Apply an even layer of water-washable adhesive (like PVP glue sticks) on the printing area to improve the first layer adhesion. After the printing you can wet the cloth with water to wipe off the residual adhesive on the Print Sheet.

3.4.3 Remove the Print

Wait for the nozzles and the Heated Bed to cool down (temperatures displayed on the Touchscreen). Remove the Print Sheet from the Heated Bed, and place it down on a stable and flat surface. Now you can remove the print.



Do NOT touch the nozzles and the Heated Bed with bare hands, as they are still extremely hot right after the printing.



Be careful with the palette knife!

Filament Runout Recovery & Power-Loss Recovery

Your printer supports filament runout recovery and power-loss recovery, so there is no need to worry about resuming printing anymore! When the filament runs out, tap **Go to Load** and load new filament to resume printing. In case of power-loss, tap **Recover** to resume printing after the power has been restored.



Filament Runout Recovery

The left nozzle has run out of filament. Tap **Go to Load** to add new filament to continue the printing.

Go to Load

Cancel



Power-Loss Recovery

There has been a power outage. Do you want to recover the job?

Recover

Cancel

Maintenance

4.1 Clean the Dust Screen

Why

The dust in the air will adhere to its dust screen on both sides of the Dual Extrusion Module in daily use. If not removed in time, the accumulated dust may hinder heat dissipation and affect the working efficiency of the module.

When

At least once every two weeks.

How

1. Prepare the cleaning tool: a cotton swab (or tissues) and water;



2. Power off the machine and detach the Dual Extrusion Module from the machine;

3. Moisten a cotton swab with water, and stick it inside the air inlet to clean the dust screen until there is no dust or water.



The cotton swab is a single-use tool. If there is still dust remaining on the dust screen after you clean it once, take a new cotton swab and repeat Step 3 to clean it again.

4.2 Clean the Nozzle

Why

During the 3D printing process, some of the extruded filament may stick to the nozzle surface. After the nozzle cools, these filament residues will solidify on its surface. If not cleaned in time, they may cause nozzle jams or leave dark marks on your next print.

When

At least once every two weeks.

How

1. Prepare the cleaning tool: the wire brush;



2. Power on the machine. Swipe left on the homepage of the Touchscreen, tap **Control** > select the target nozzle, and heat it to 200°C ;



3. After the nozzle is heated, scrape off the filament residue from the nozzle surface with the wire brush.



Be careful of the hot nozzle surface!



Do NOT scrape against the black thermal insulating casing during cleaning.

4.3 Clean the Extruder Gears

Why

Strong friction will be generated between the extruder gears and the filament during printing, due to which lots of small shavings will be ground away from the filament. If not cleaned regularly, the teeth of the extruder gears may be flattened by the accumulated shards and particles, which will inhibit the gears from gripping and pushing the filament through the hot end and finally affect the printing results.

When

At least once every two weeks.

How

1. Prepare the cleaning tool: a banister brush (not provided);
2. Unload the filament from the module;
3. Power off the machine, open the front cover of the module, and press the extruder buckle downwards to expand the dual-gear extruder;



4. Clean the filament shavings from the extruder gears with the banister brush.

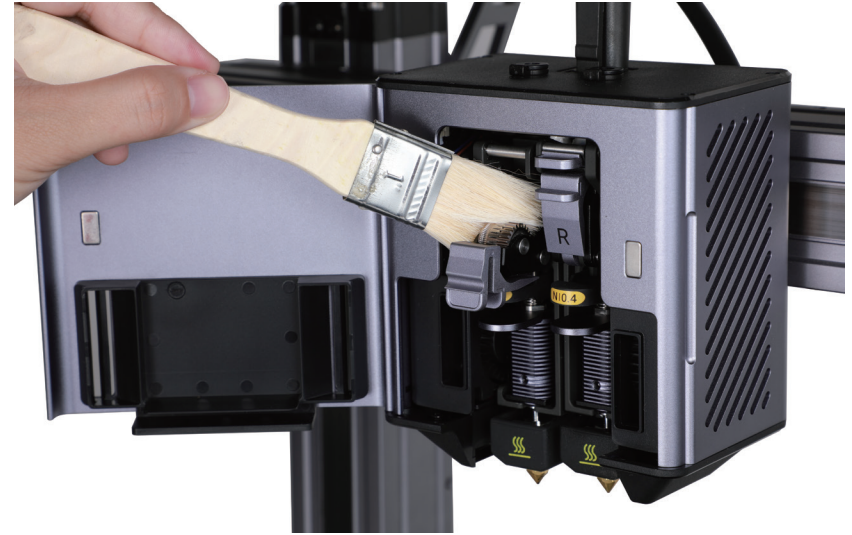

4.4 Store the Filament

Most 3D printing filaments (especially PA, PVA, and PETG) absorb moisture from the air, while printing with wetted filament is likely to clog the nozzles or affect the printing quality. Therefore, the filament should be used up within one month once unpacked.

If a spool of filament will be left unused for a long time, take the following steps to store it properly:

1. Unload the filament from the module;
2. Store the filament in a vacuum-sealed bag filled with desiccant;
3. Mark the unpacking date on the bag.



Original Instruction

Y.3.B.A.0093-02 V1.1.0