

snapmaker | F250

QUICK START GUIDE

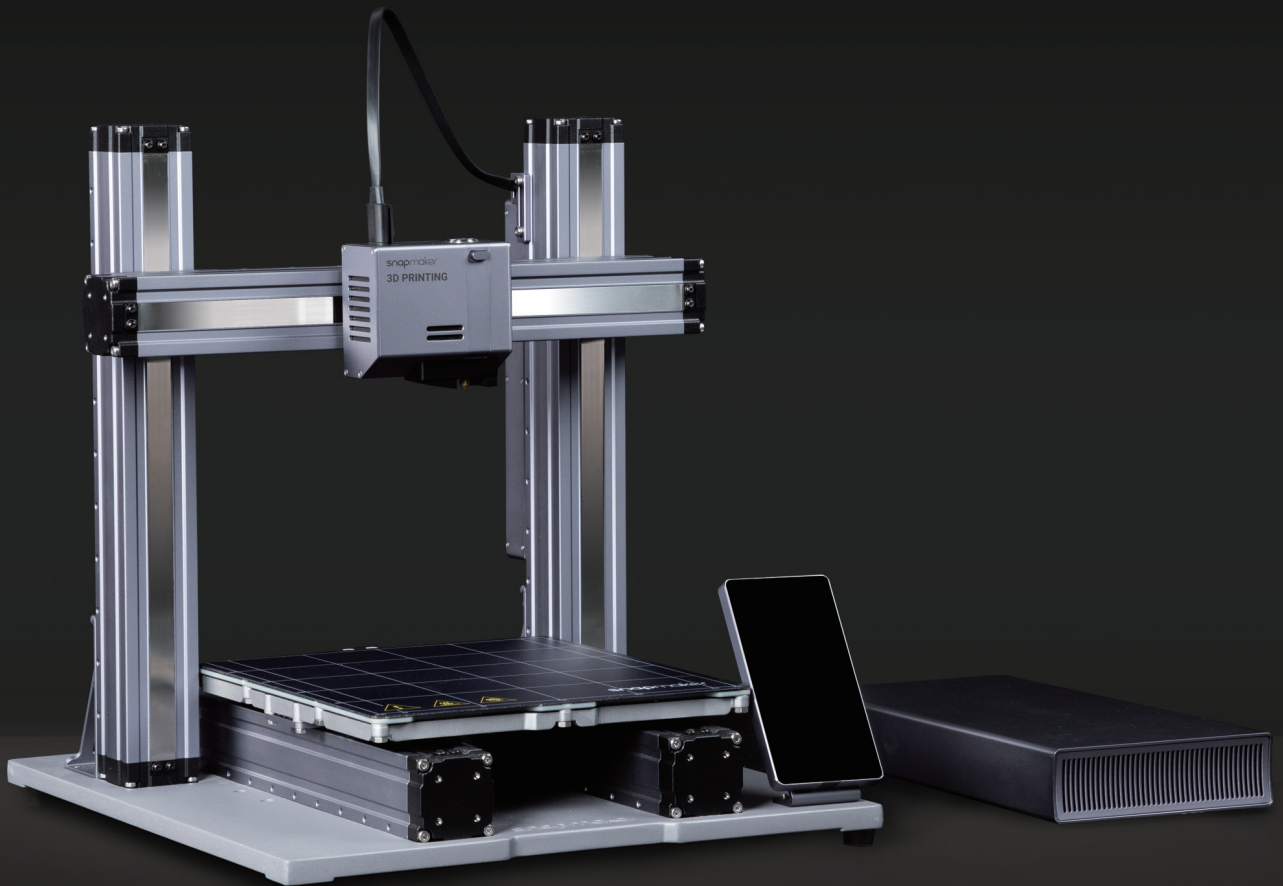

MAKE SOMETHING WONDERFUL



CONTENTS

01 Before You Start

10 Machine Assembly

36 3D Printing

BEFORE YOU START



Copyright © 2021 Snapmaker. All rights reserved.

This language version of the manual is verified by the manufacturer (Original Instruction). No part of this publication, including pictures may be reproduced or made public, whether by printing, photocopying, microfilm or by any other means whatsoever, without the prior written permission of Snapmaker.

1.1 Disclaimer

Please read and understand the contents of the manual of this product carefully. Failure to read the manual may lead to personal injury, inferior results or damage to the Snapmaker products. Always make sure that anyone who uses this product knows and understands the contents of this manual to make the most out of it.

This manual is provided for reference purposes only, we do not warrant the accuracy or completeness of the information provided by this manual. We reserve the right to modify or revise this manual in our sole discretion at any time without notice, users can download the most up-to-date version of this manual on our official website.

When making objects using Snapmaker products, users remain responsible to ensure that they do not infringe any third party intellectual property rights or violate any applicable laws or regulations. The conditions or methods used for assembling, handling, storage, use, maintaining or disposal of this product are beyond our control. For this reason, we do not assume responsibility and expressly disclaim liability for loss, injuries, damage, or expense arising out of or in any way connected with the assembly, handling, storage, use, maintaining or disposal of this product.

1.2 Intended Use

Snapmaker modular 3D printers are the ideal choice for beginners, hobbyists who prefer more customized options, as well as engineers and designers who want to make large objects or fine parts with outstanding fabrication quality. Snapmaker modular 3D printers are intended for use under the guidelines provided in the product manual. When making objects using Snapmaker modular 3D printers, users remain responsible to qualify and validate the application of the created object for its intended use, especially for applications in strictly regulated areas like medical devices and aeronautic.

1.3 Safety and Compliance

General Safety Information

- Always operate this machine indoors on a solid horizontal table or workbench.
- Do not expose this machine to rain or wet conditions.
- Keep children and bystanders away while operating this machine. It requires the supervision and assistance of an adult when children use this machine.
- Stay alert, watch what you are doing and use common sense when operating this machine. Do not use this machine while you are tired or under the influence of drugs, alcohol or medication.
- Do not reach inside the machine or touch the moving parts while the machine is still in operation, as it may cause injury.
- Do not leave the machine unattended while it is still on.

In all EU member states, operation of 5150-5250 MHz is restricted to indoor use only.



AT	BE	CY	CZ	DK	EE	FI
FR	DE	EL	HU	IE	IT	LV
LT	LU	MT	NL	PL	PT	SK
SI	ES	SE	UK	BG	RO	HR

Turn off the machine immediately and stop using this product, if any of the following occurs:

- You smell burning in this machine at any point.
- The machine stops working.
- You see any damage to the interior components of this machine.
- Unusual lights, sparks, or sounds come out of this machine which were not occurring previously.

3D Printing Safety

- Do not touch the nozzle, Print Sheet and Heated Bed when the machine is printing or heating.
- Always unplug the power cord from the electrical outlet before performing maintenance or modifications.
- Set up the printer in a well-ventilated place when printing with ABS. The melting of some materials may release toxic fumes.

FCC Compliance

This equipment has been tested and found to comply with the limits for a Class B digital device, pursuant to part 15 of the FCC Rules. These limits are designed to provide reasonable protection against harmful interference in a residential installation. This equipment generates, uses and can radiate radio frequency energy and, if not installed and used in accordance with the instructions, may cause harmful interference to radio communications. However, there is no guarantee that interference will not occur in a particular installation. If this equipment does cause harmful interference to radio or television reception, which can be determined by turning the equipment off and on, the user is encouraged to try to correct the interference by one or more of the following measures:

- Reorient or relocate the receiving antenna.
- Increase the separation between the equipment and receiver.
- Connect the equipment into an outlet on a circuit different from that to which the receiver is connected.
- Consult the dealer or an experienced radio / TV technician for help.

Caution: Any changes or modifications to this device not explicitly approved by manufacturer could void your authority to operate this equipment.

This device complies with part 15 of the FCC Rules. Operation is subject to the following two conditions:

(1) This device may not cause harmful interference, and (2) this device must accept any interference received, including interference that may cause undesired operation.

This equipment complies with FCC radiation exposure limits set forth for an uncontrolled environment. This equipment should be installed and operated with minimum distance 20cm between the radiator & your body.

ISED Compliance

This device complies with Innovation, Science and Economic Development Canada License exempt RSS standard(s). Operation is subject to the following two conditions:

(1) this device may not cause harmful interference, and (2) this device must accept any interference received, including interference that may cause undesired operation of the device.

Le présent appareil est conforme aux CNR d'Innovation, Sciences et Développement économique Canada applicables aux appareils radio exempts de licence. L'exploitation est autorisée aux deux conditions suivantes :

(1) l'appareil ne doit pas produire de brouillage, et (2) l'utilisateur de l'appareil doit accepter tout brouillage radioélectrique subi, même si le brouillage est susceptible d'en compromettre le fonctionnement.

The device is compliance with RF exposure guidelines, users can obtain Canadian information on RF exposure and compliance. The minimum distance from body to use the device is 20cm.

Le présent appareil est conforme Après examen de ce matériel aux conformité ou aux limites d'intensité de champ RF, les utilisateurs peuvent sur l'exposition aux radiofréquences et conformité d'acquérir les informations correspondantes. La distance minimale du corps à utiliser le dispositif est de 20cm.

1.4 Label on Your Snapmaker

Safety Label	Hazard	Warning	Location
	Hot surface	Avoid contact with hot surface.	On the 3D Printing Module, Print Sheet and Heated Bed

1.5 Specifications

General	
Frame Material Connectivity Touchscreen Software Supported File Types Supported OS Rated Power	Aluminum Alloys Wi-Fi, USB Cable, USB Disk 5" TFT, Android System Snapmaker Luban and third-party software .stl, .obj, and more formats to be added MacOS, Windows, Linux 320 W
3D Printing	
Build Volume Heated Bed Temperature Layer Resolution Nozzle Temperature Nozzle Diameter Supported Materials	F250: 230 x 250 x 235 mm F350: 320 x 350 x 330 mm F250: Up to 100°C F350: Up to 80°C 50 - 300 microns Up to 275°C 0.4 mm PLA, ABS, TPU, Wooded PLA, etc.

Note: Design and specifications are subject to change without notice.

1.6 Parts List

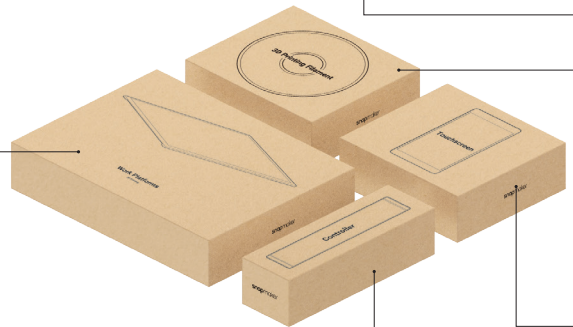
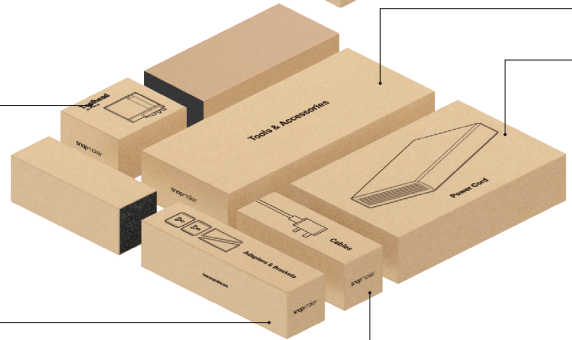
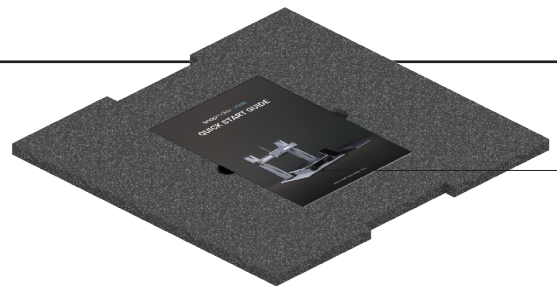
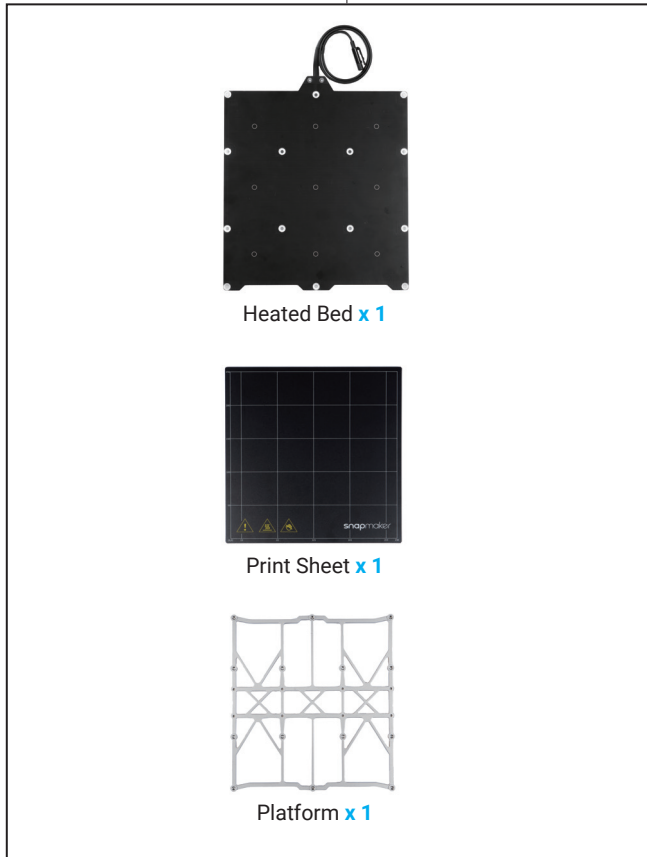
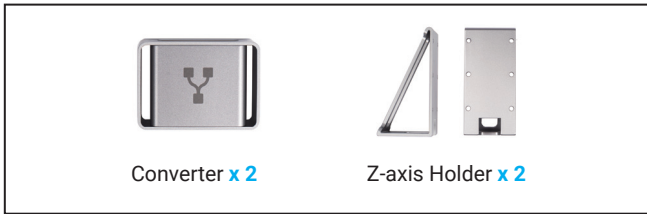
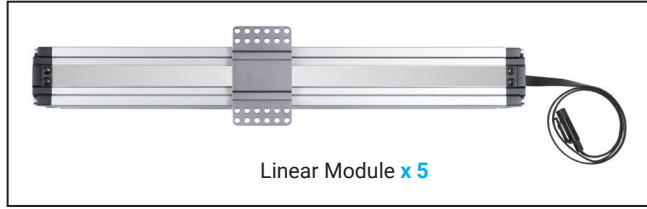



Quick Start Guide **x 1**



Power Module **x 1**



Calibration Card **x 2**



Filament Holder Sheet **x 1**



Tool Box **x 1**



Filament Holder Tube **x 1**



USB Cable **x 1**



DC Power Cable **x 1**



AC Power Cable **x 1**



Filament **x 1**



Touchscreen **x 1**



Touchscreen Holder **x 1**

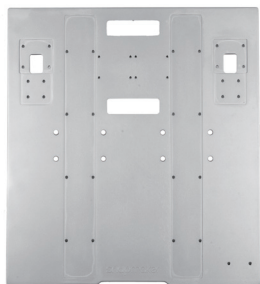

Base Plate **x 1**



Controller **x 1**



Toolhead Cable **x 1**



Y Conversion Cable **x 1**



Z Conversion Cable **x 1**

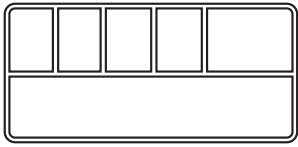

Tool Box



M4 x 30 Screw x 12



M4 x 10 Hex Socket Head Screw x 17



M4 x 8 Screw x 68



M4 x 10 Hex Flat Head Screw x 22



Foot x 4 + M4 x 10 Hex Socket Head Screw x 4



Divider x 6



Cable Holder x 1



Hot End Kit x 1



Cable Tie x 1



Tweezers x 1



USB Disk x 1



Palette Knife x 1



Diagonal Pliers x 1



Screwdriver x 1

1.7 Video Tutorials

Apart from this Quick Start Guide, we also make video tutorials. Read this guide to finish assembly, and if you are feeling adventurous, tricks that are not included in this guide can be found in the video tutorials. Visit our website at <https://support.snapmaker.com/hc/en-us> -> select **Snapmaker 2.0** -> Go to **Video Tutorial**.

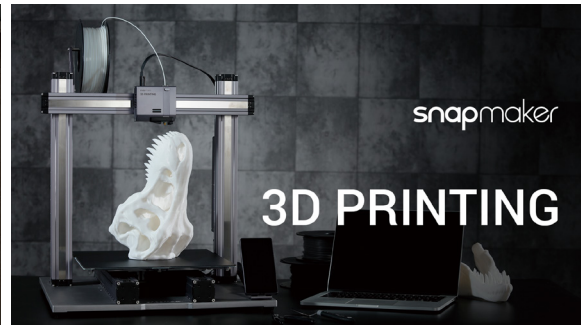

1.8 Used Symbols



CAUTION

Ignoring this type of message might result in malfunction or damage of the machine and injuries to users.



NOTE

Details you should be aware of throughout the process.



TIPS

Tips offer you convenient operations and additional options.



Make sure that the highlighted part is facing the right way.



Do not tighten the screws when this symbol appears. Always tighten the screws when it is absent.

1.9 Get the Screwdriver Ready



The screwdriver head H 2.5 is used for assembling the machine. The other heads are used for maintenance. Make sure the screw head holder has been put back inside of the handle before use.



MACHINE ASSEMBLY



01/24

Attach the feet to the Base Plate.

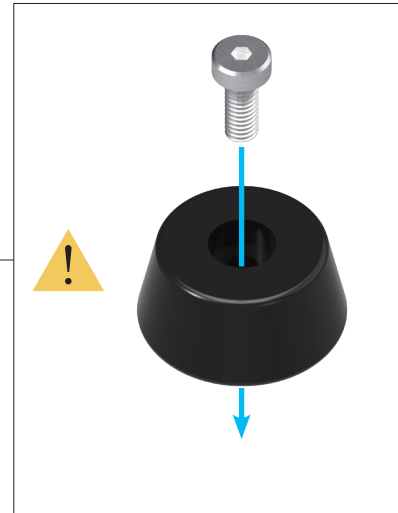
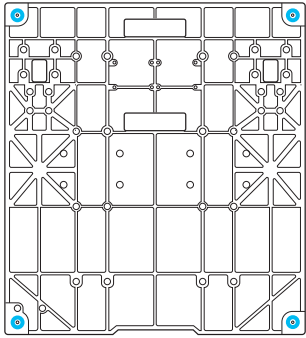

M4 x 10 Hex Socket Head
Screw x 4

Foot x 4

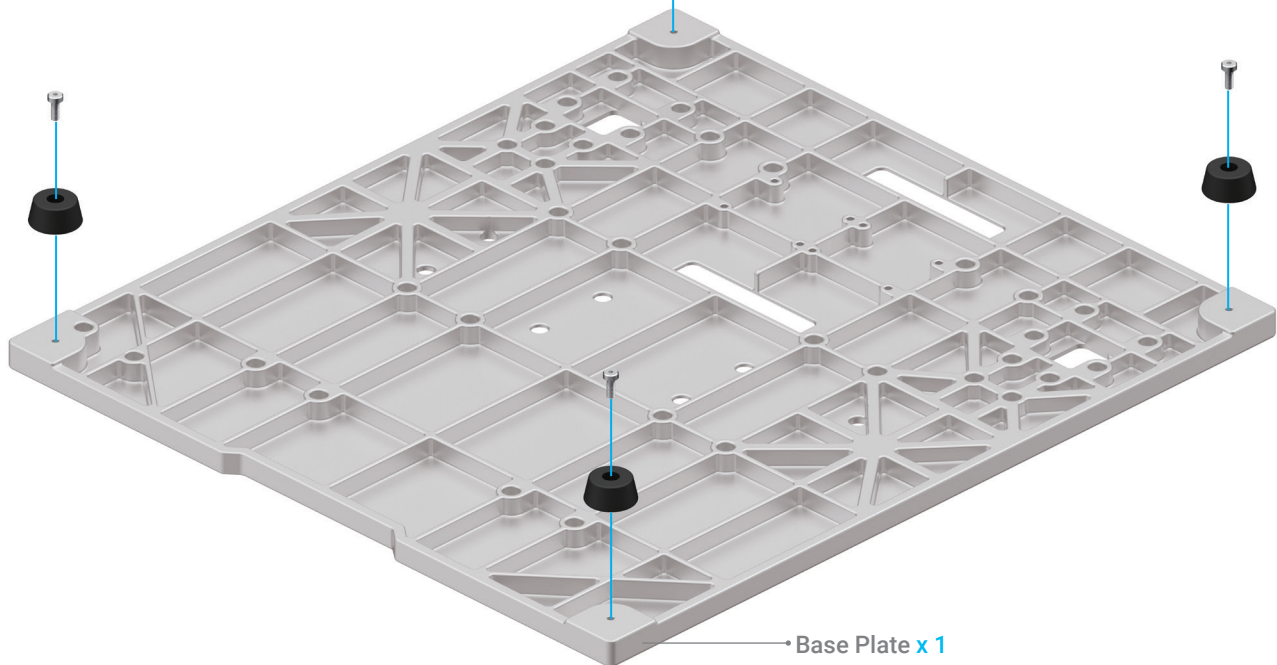

Base Plate x 1

02/24

All Linear Modules must be assembled in their intended position. Now, identify two Linear Modules with the laser pattern "Lead 20 mm"; they will be the Y Axes.

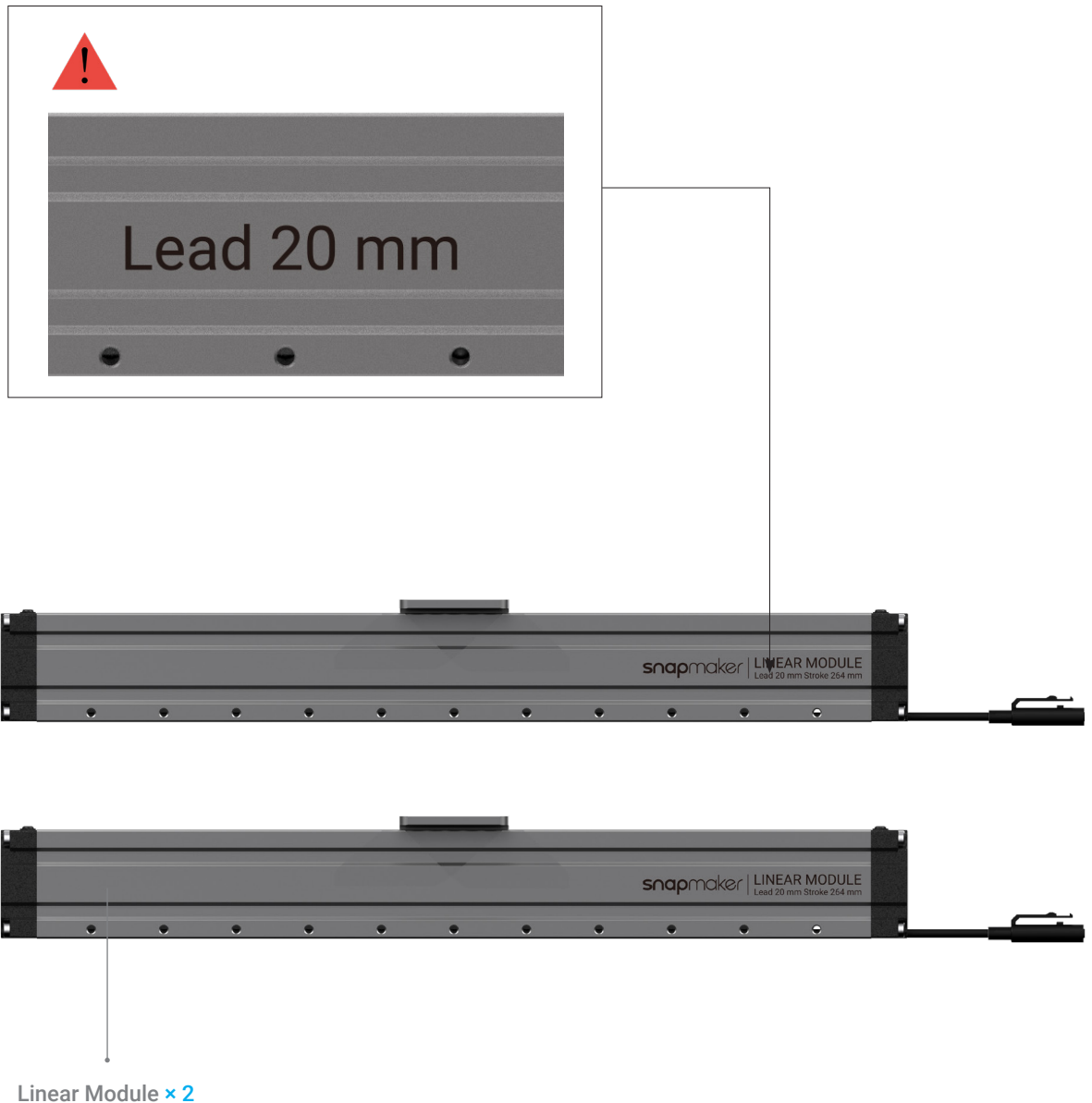

There are three Linear Modules engraved with the laser pattern "Lead 20 mm". The unused one will be defined as X Axis in Step 13.

03/24

Make sure the sliders are aligning with each other. If not, you can move them to the same position as illustrated.



Hold the Linear Modules carefully to prevent them from falling.

1

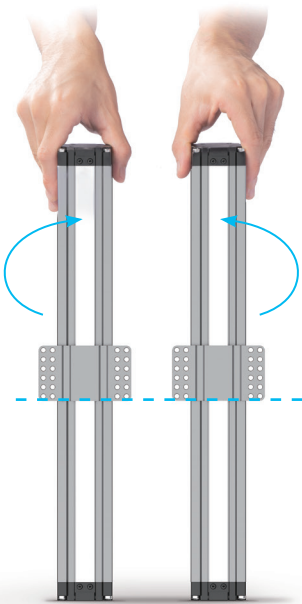

2

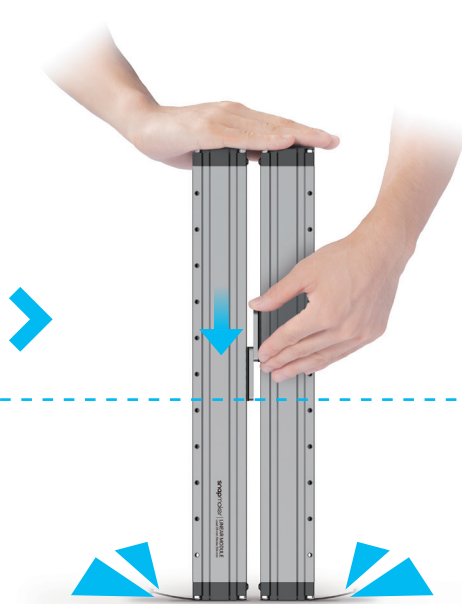

DONE!

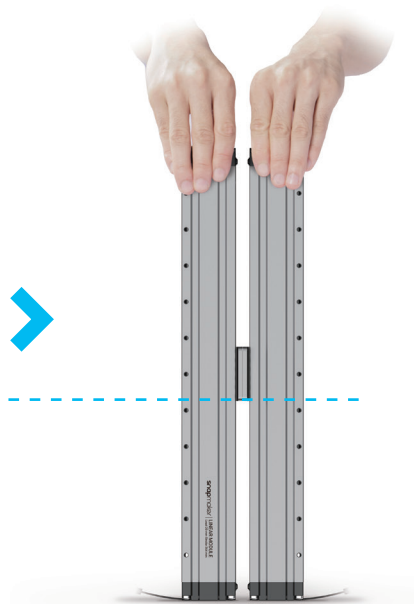

Do not press the steel strip.

04/24

Attach the Y Axes to the Platform. Do not tighten the screws until Step 6.

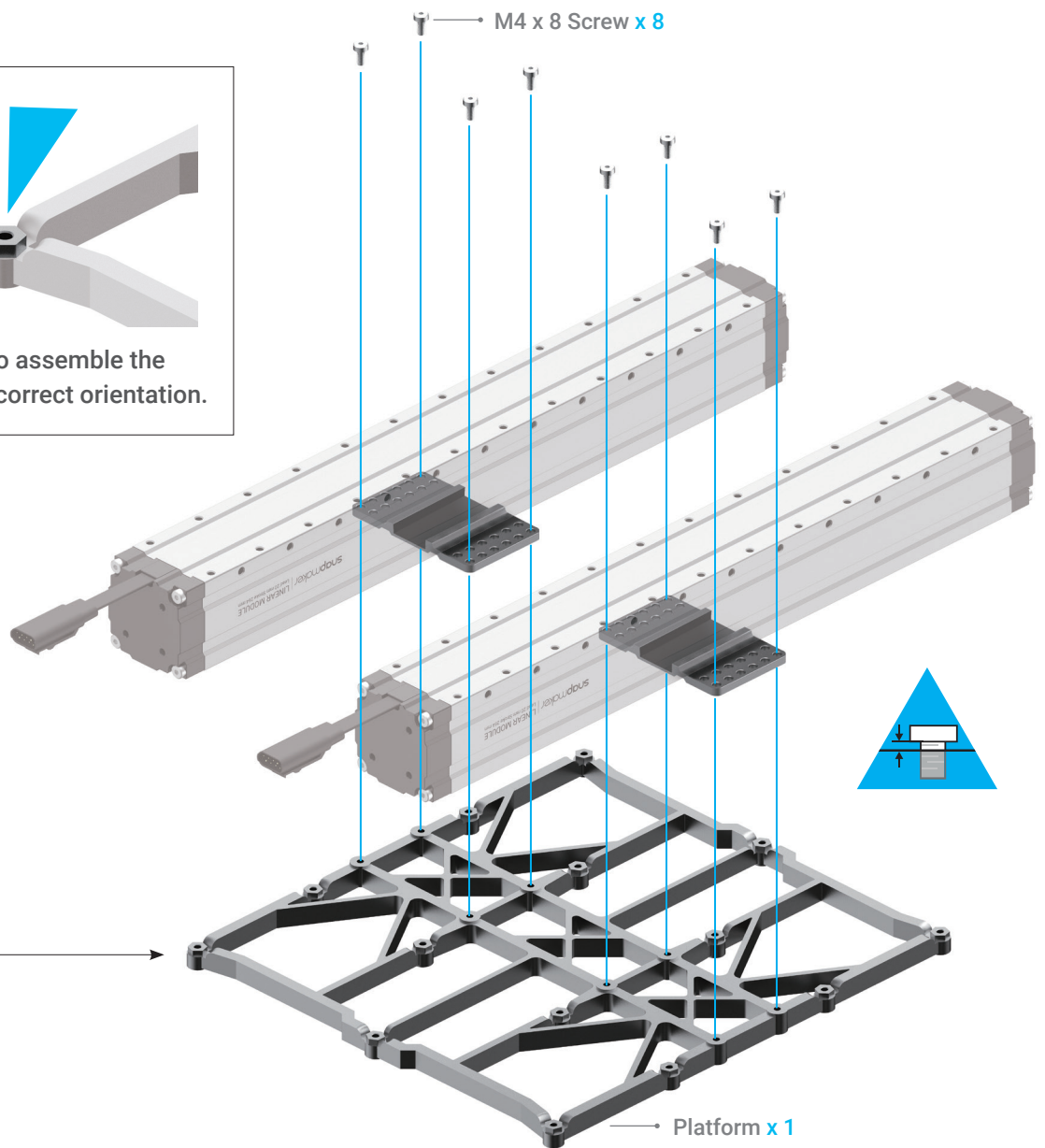
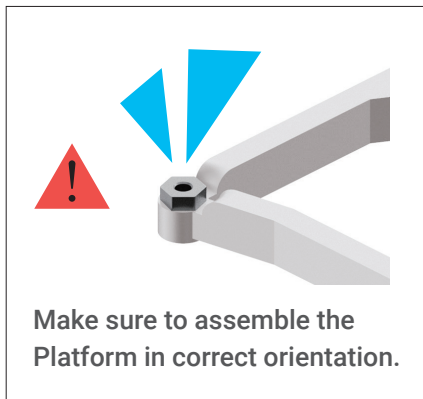
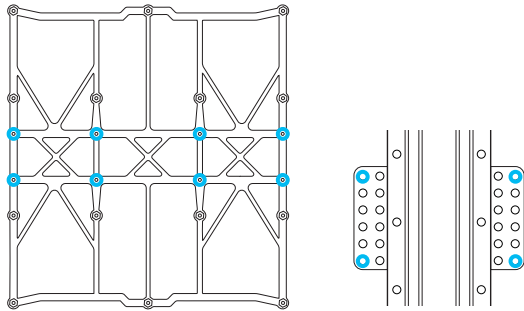

05/24

Attach the Y Axes to the Base Plate.

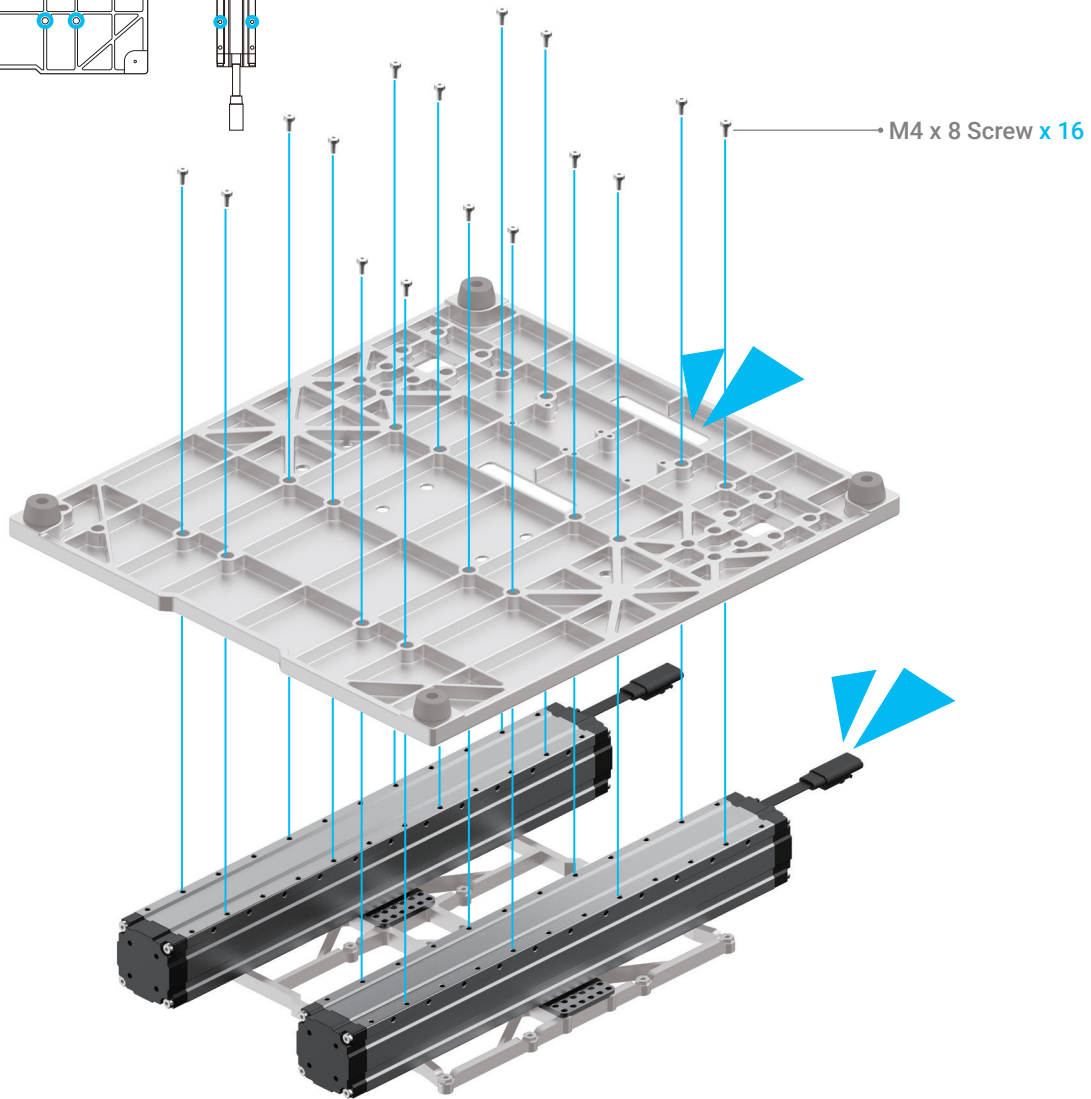
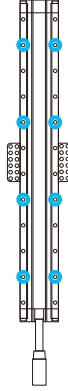
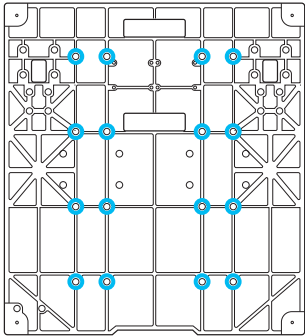

06/24

Tighten the screws on the Y-axis sliders.

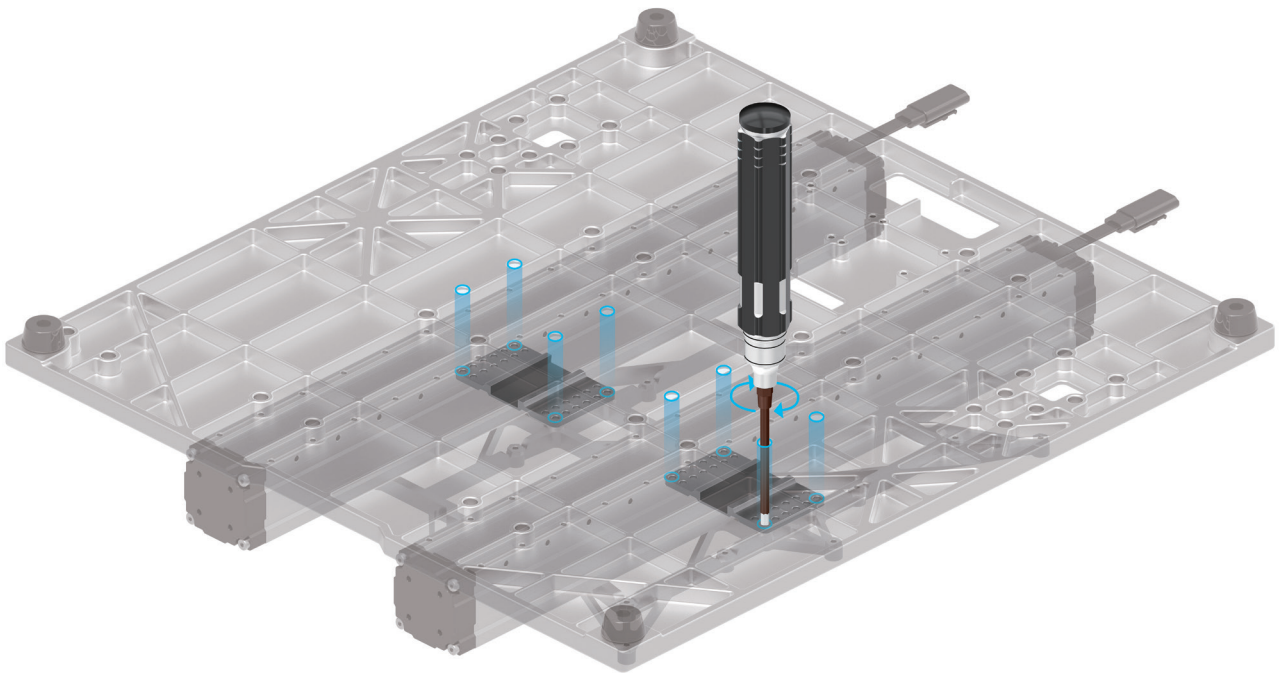
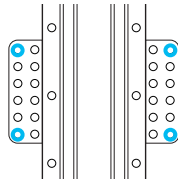
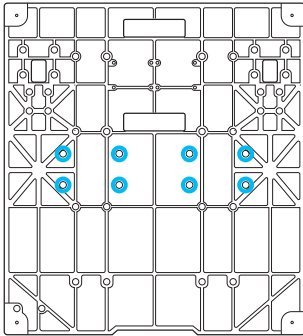

If the screws on the sliders are not aligning with the screw holes on the Base Plate, move the Platform to the proper position.

07/24

Attach the Z-axis Holders to the Base Plate.

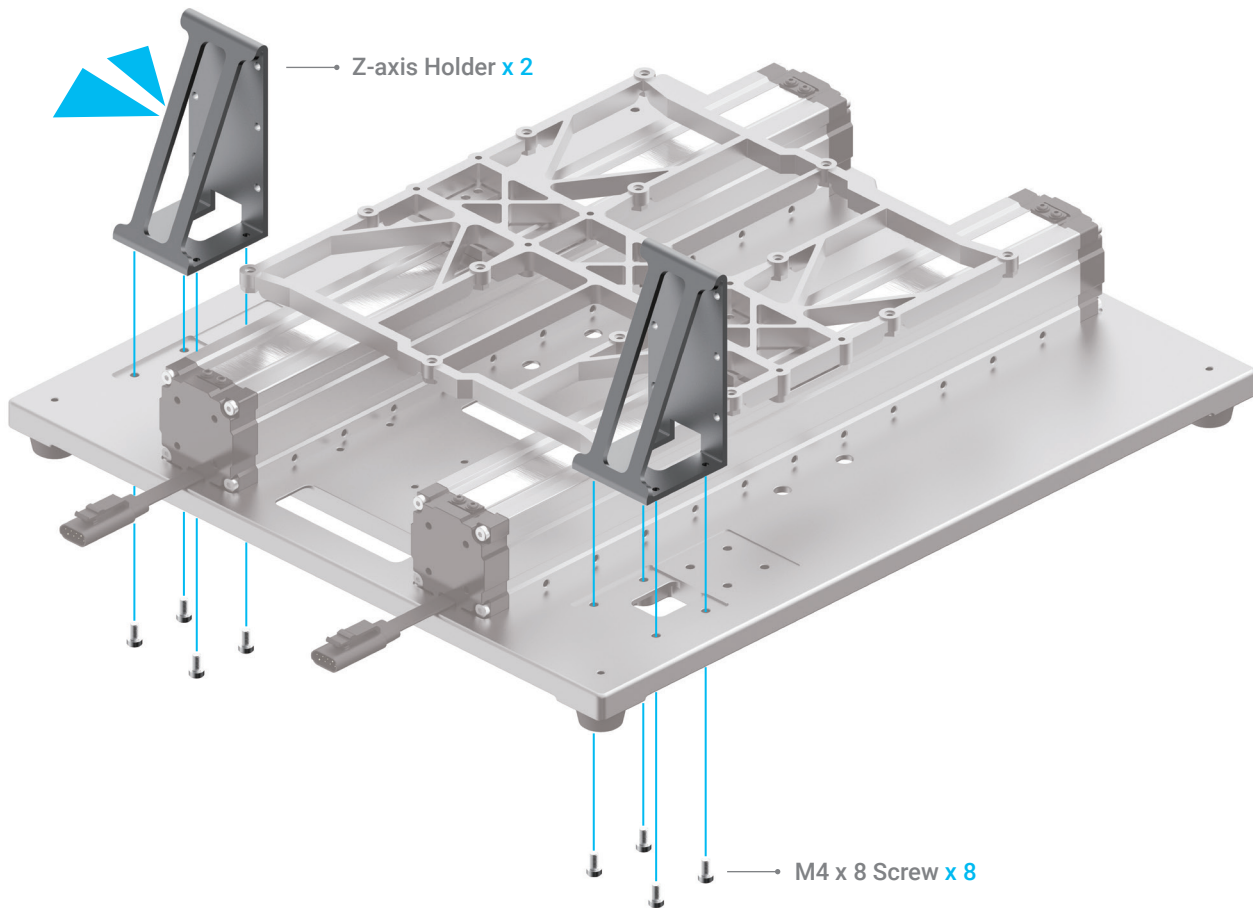
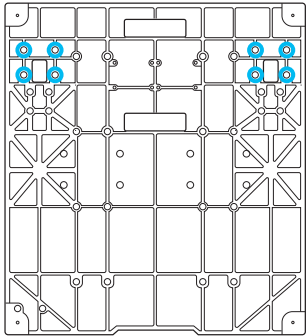

08/24

Attach the Touchscreen Holder to the Base Plate.

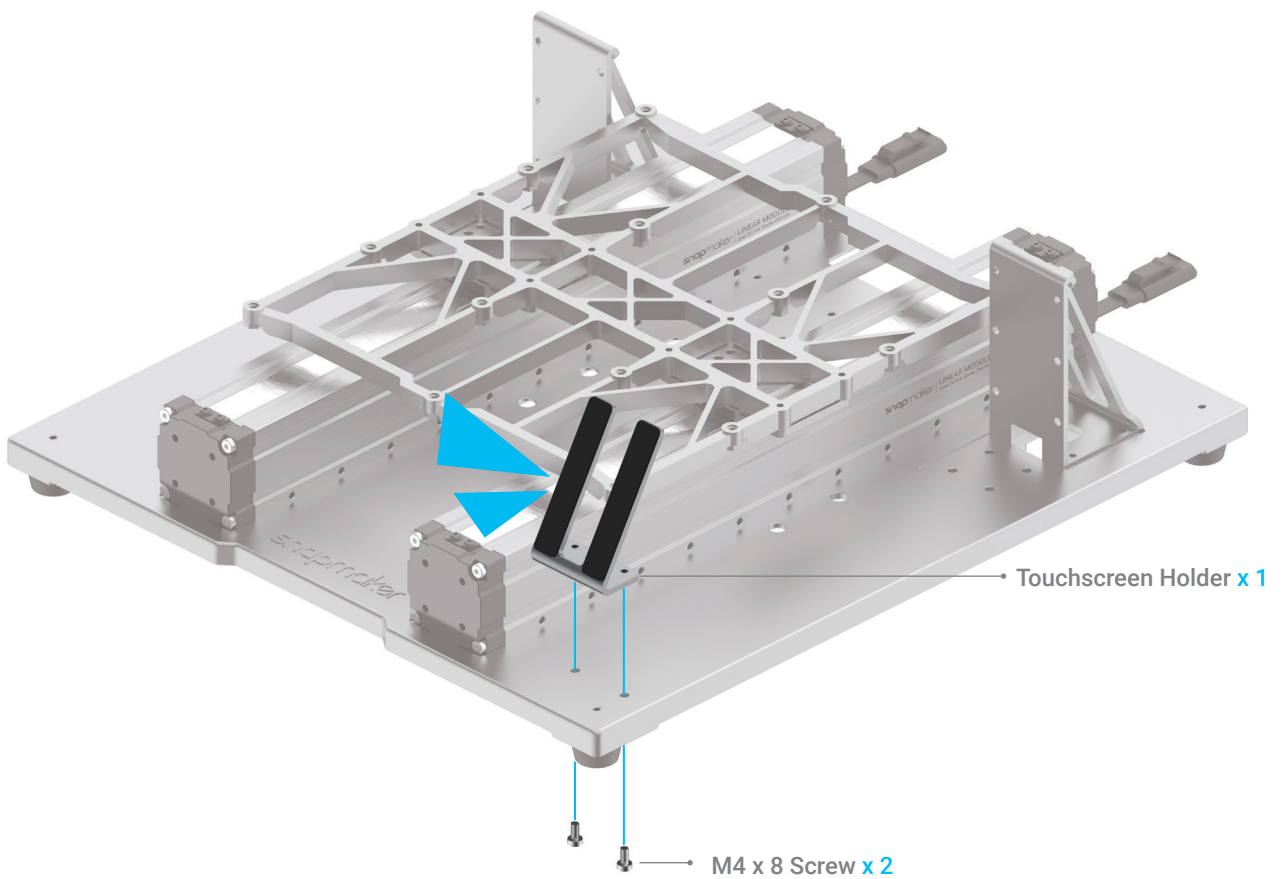
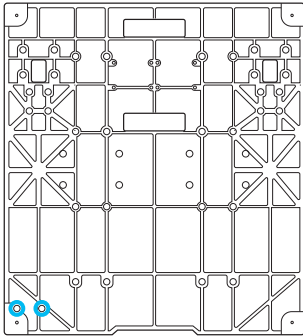

09/24

Identify the two Linear Modules with the laser pattern "Lead 08 mm". They will be the Z Axes.

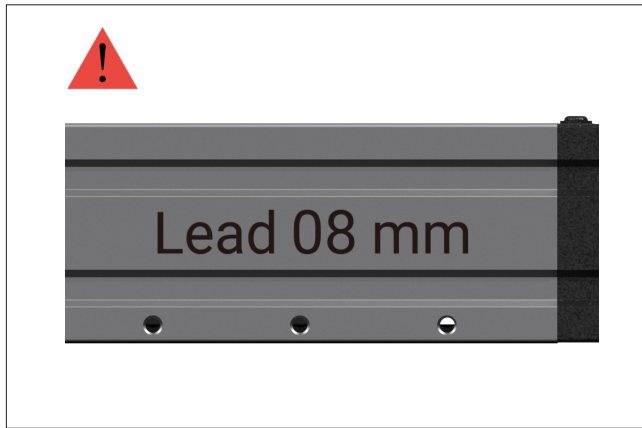

Linear Module x 2

10/24

Thread the connecting cables through the holes of the holders, and then attach the Z Axes to the Z-axis Holders. Do not tighten the screws until Step 14.

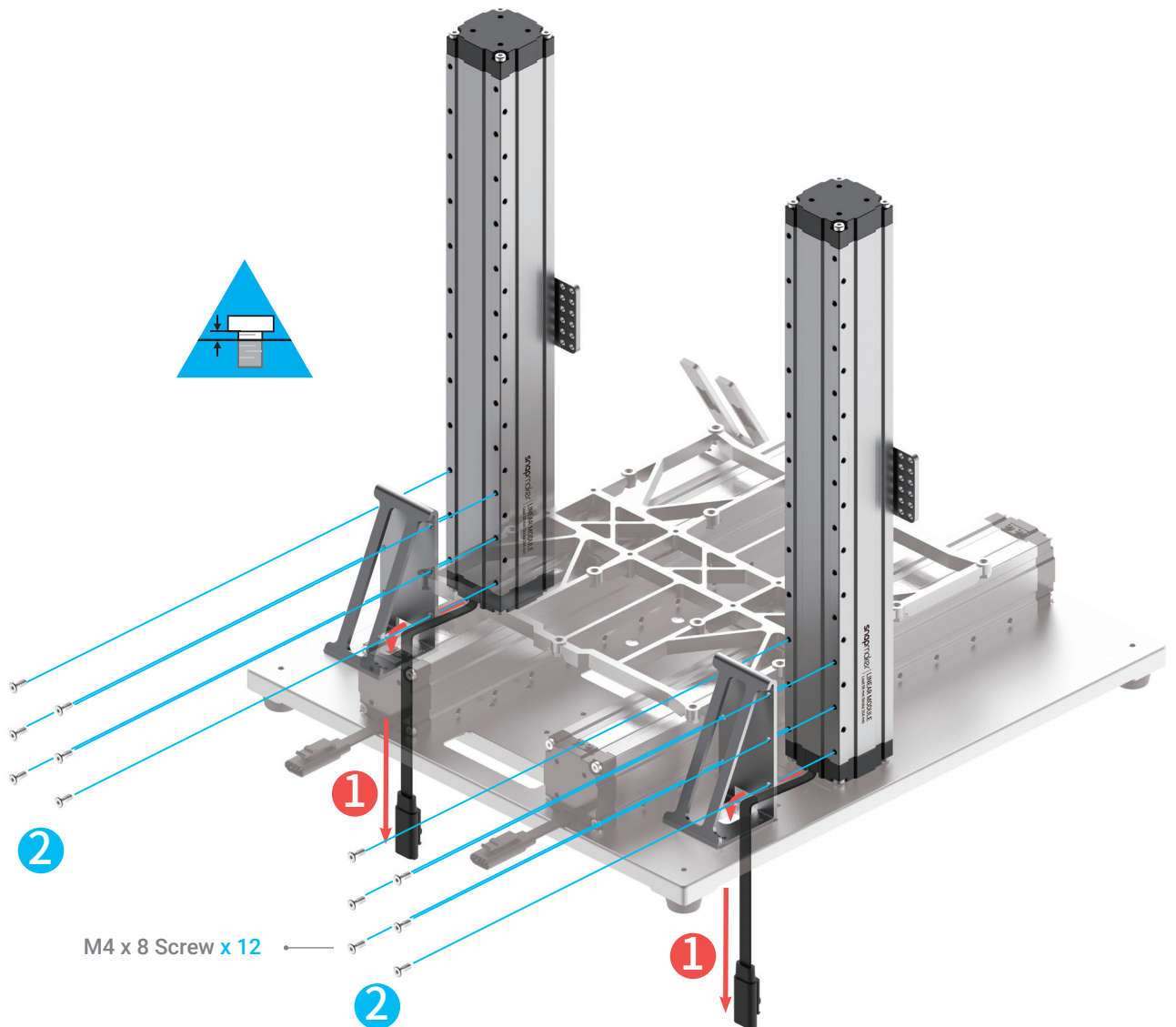
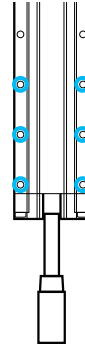
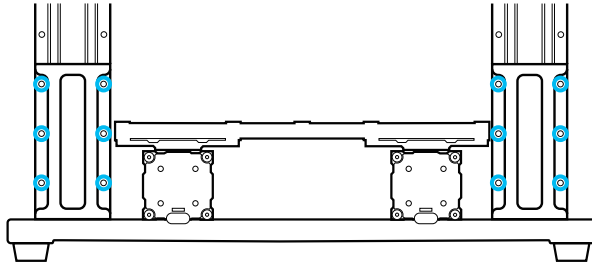

11/24

Install the screws to the bottom of the Z Axes. Do not tighten the screws until Step 15.

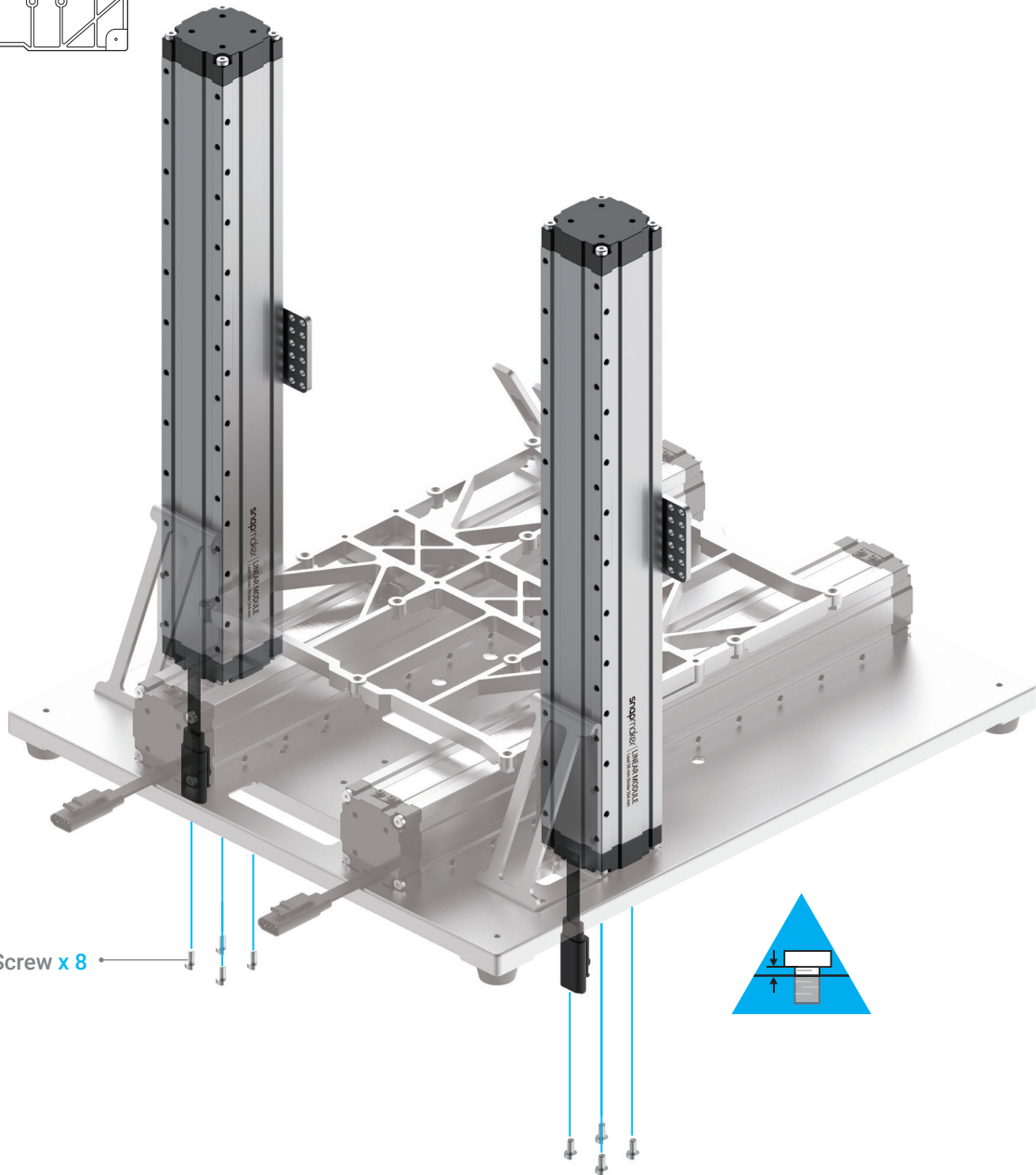
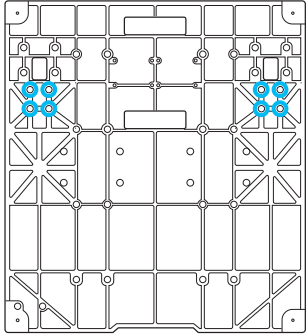

M4 x 8 Screw x 8

12/24

From the middle, move the Platform to the position as illustrated. Then move the Z-axis sliders to the farthest end.

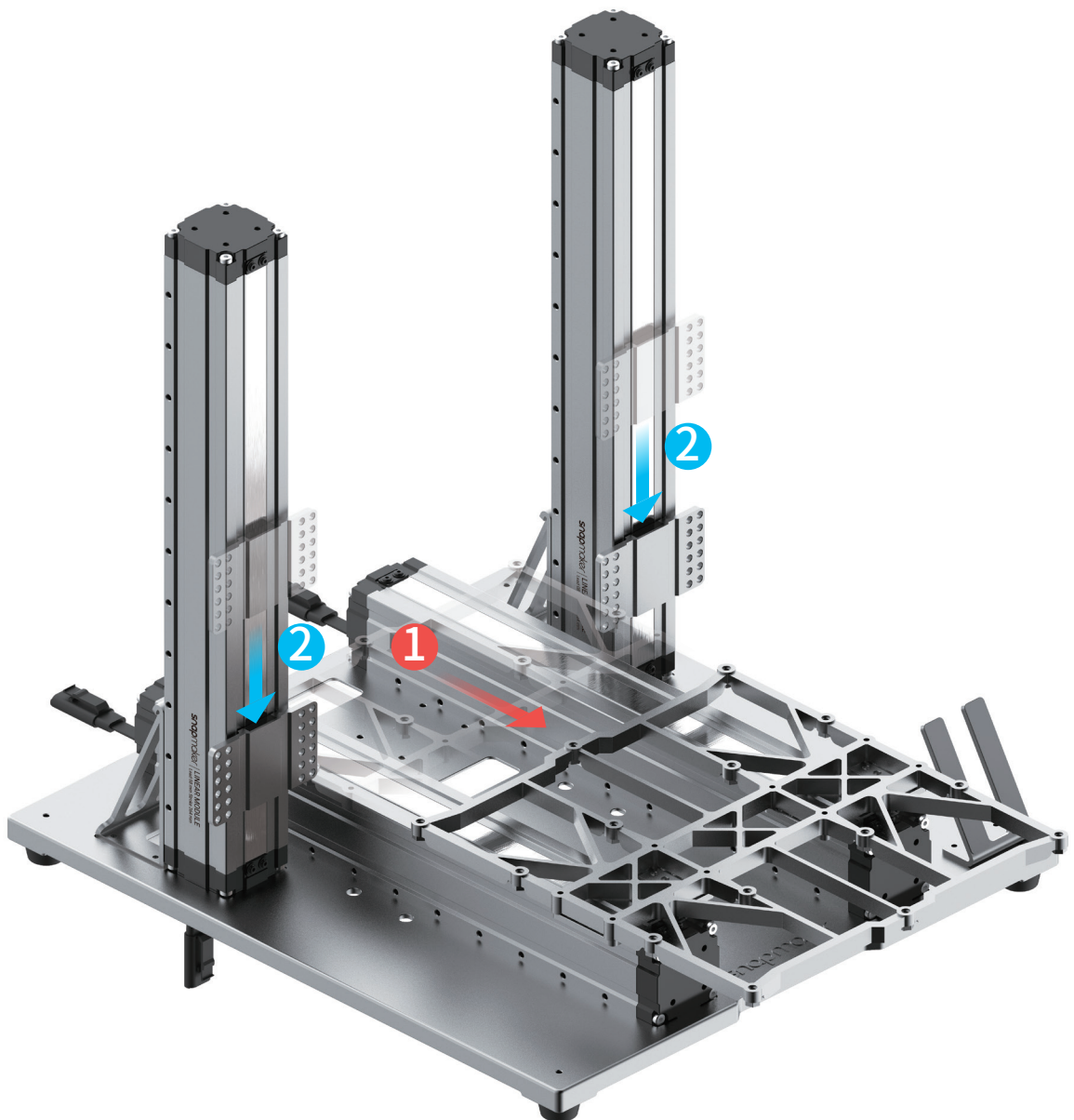
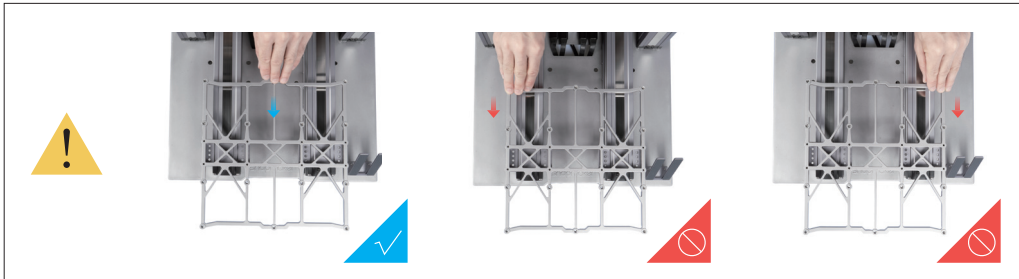

13/24

The last Linear Module with the laser pattern "Lead 20 mm" will be the X Axis. Attach the X Axis to the Sliders on the Z Axes.

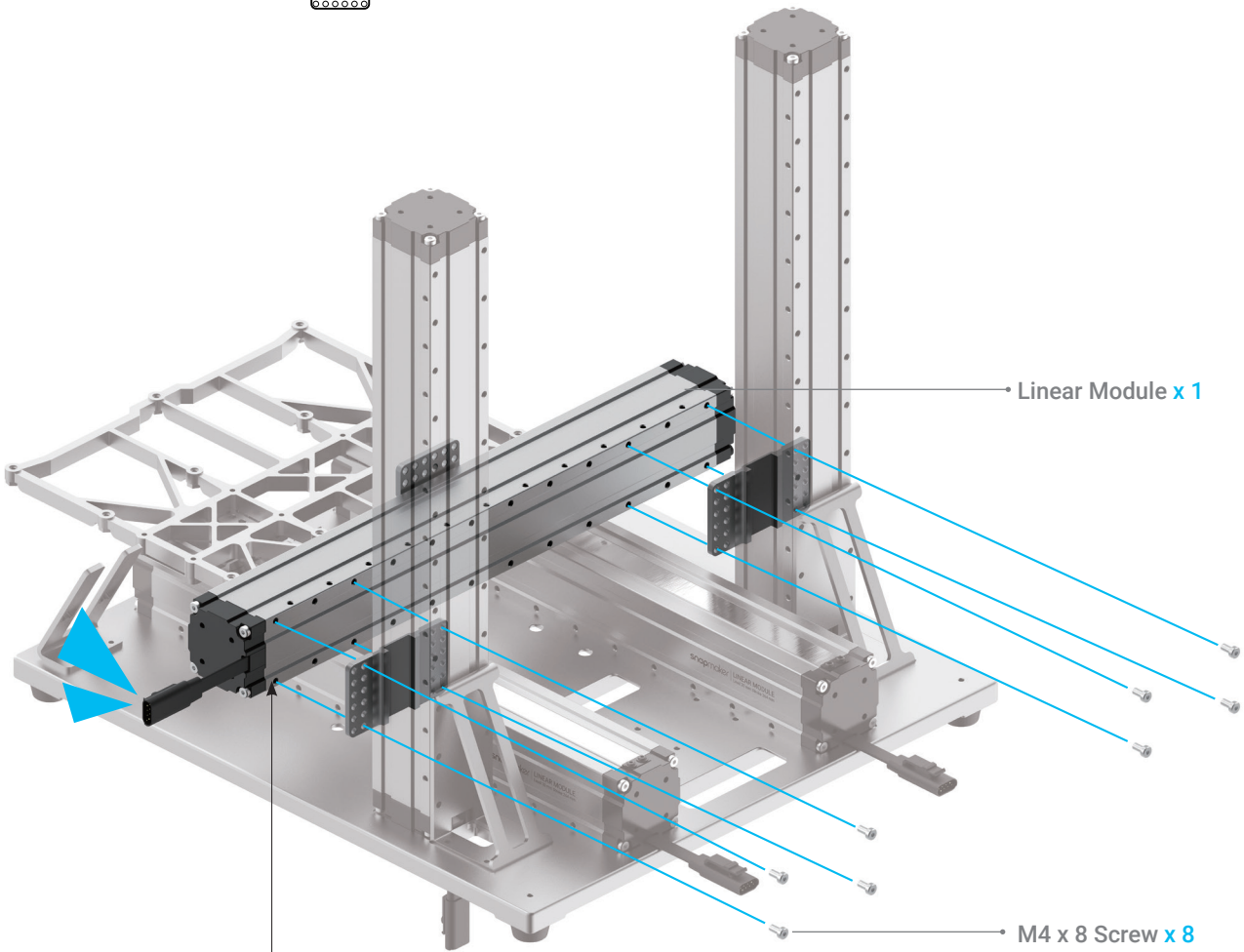
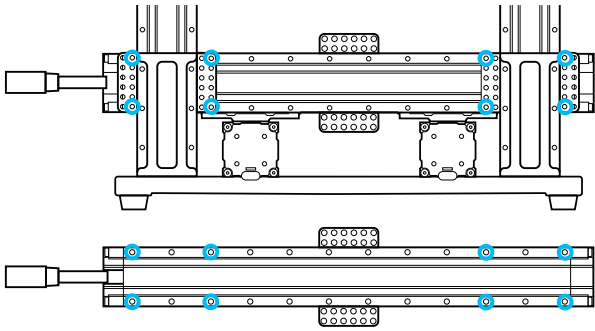

14/24

Tighten the screws that are used to attach the Z Axes to the Z-axis Holders.

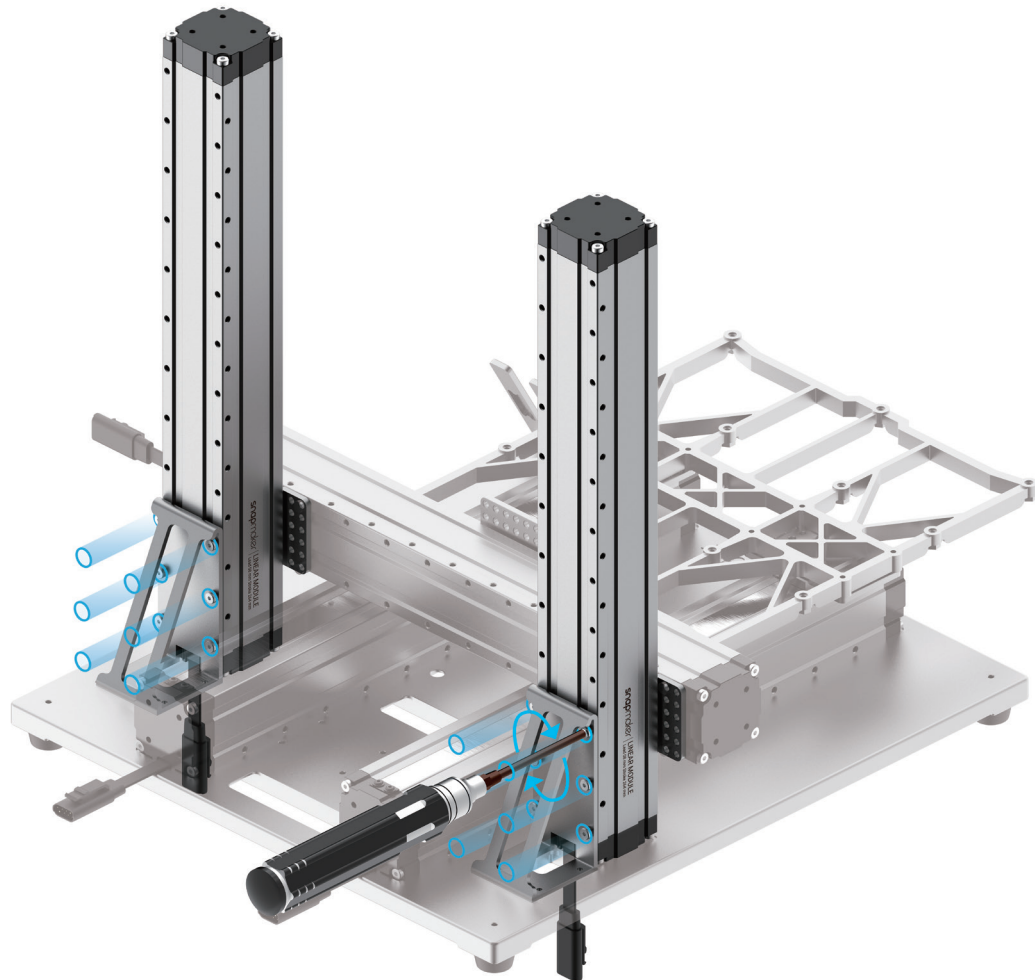
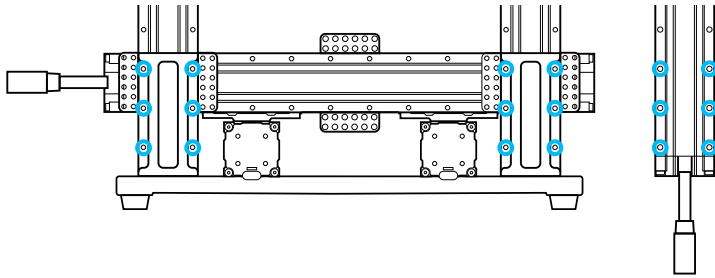

15/24

Tighten the screws to the bottom of the Z Axes.

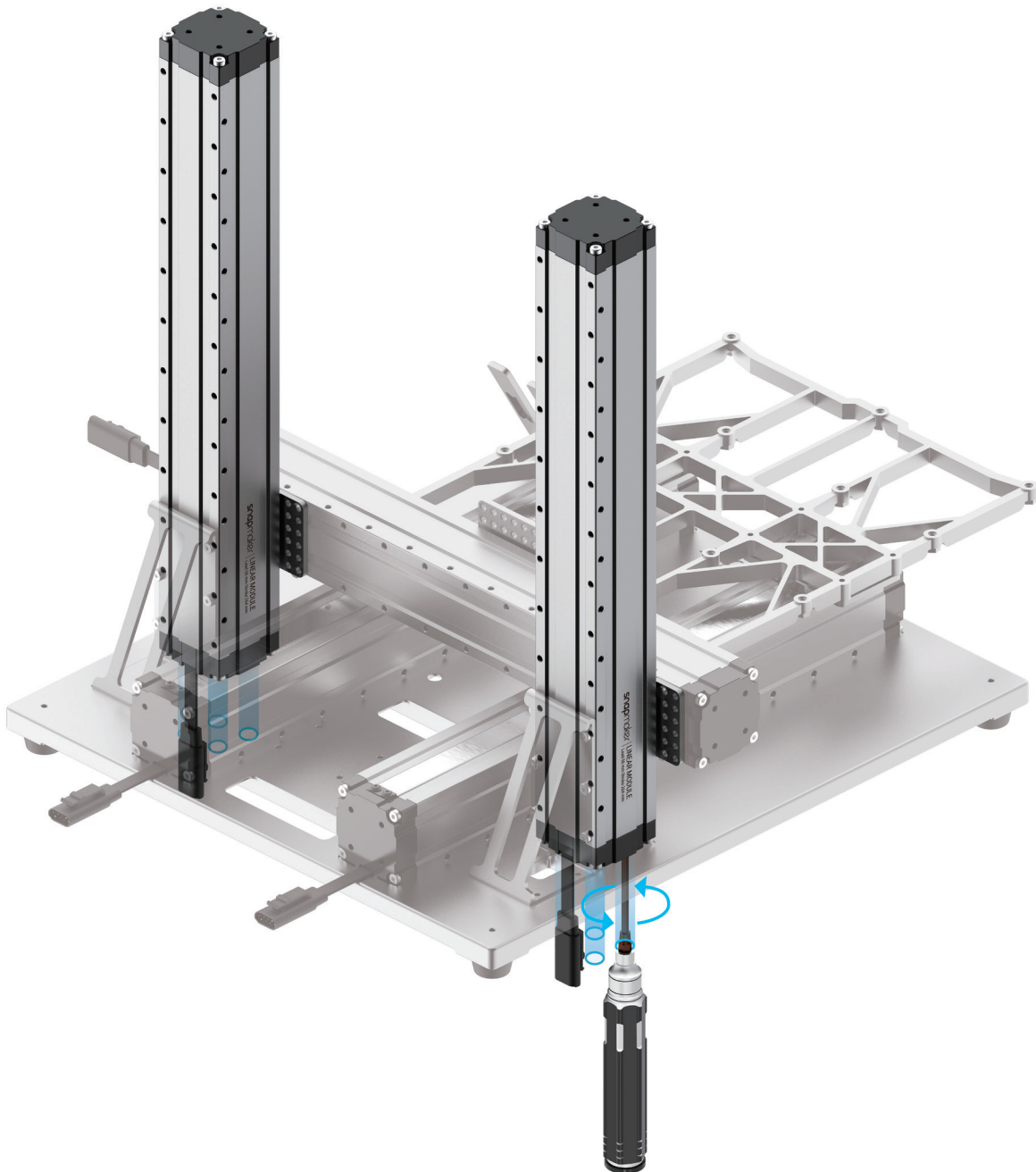
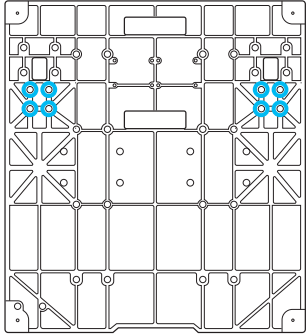

16/24

Put your hands at each end of the Linear Module, and then move the X Axis to the top.



Make sure both ends of the Linear Module are in horizontal alignment with each other throughout the process.

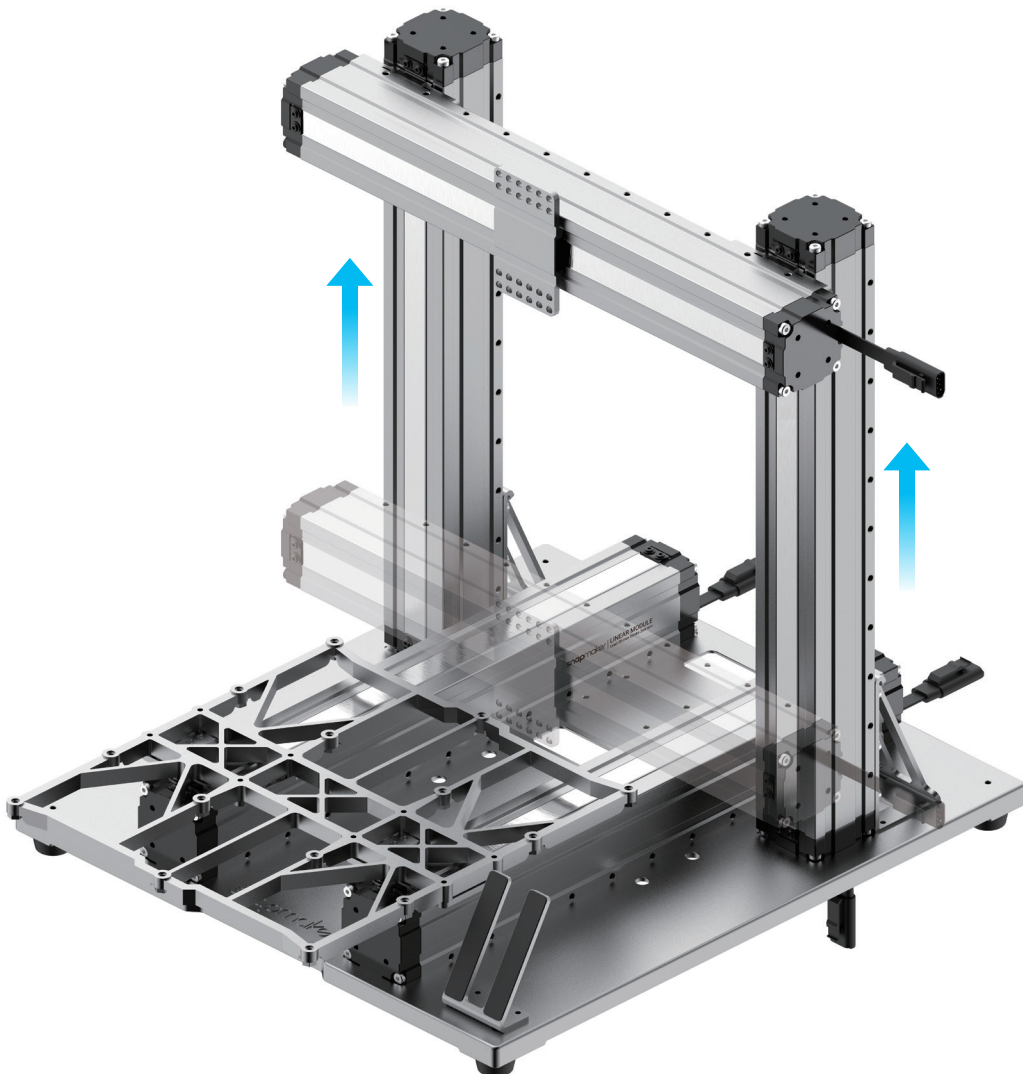

17/24

Locate the Y Conversion Cable, and the attached cable on both of the two Y Axes as illustrated. Connect them to the Converter.

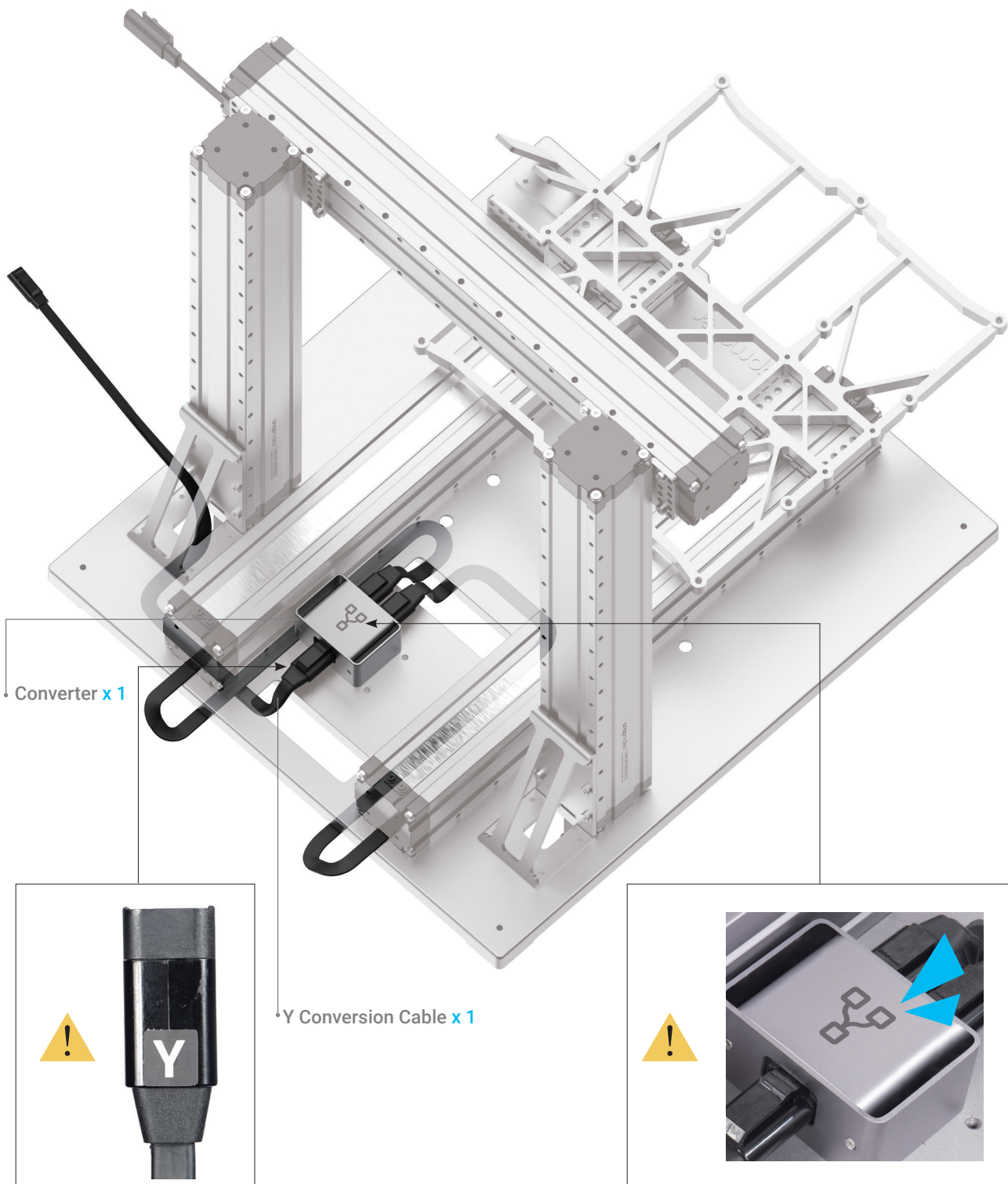

18/24

Attach the Y-axis Converter to the Base Plate.

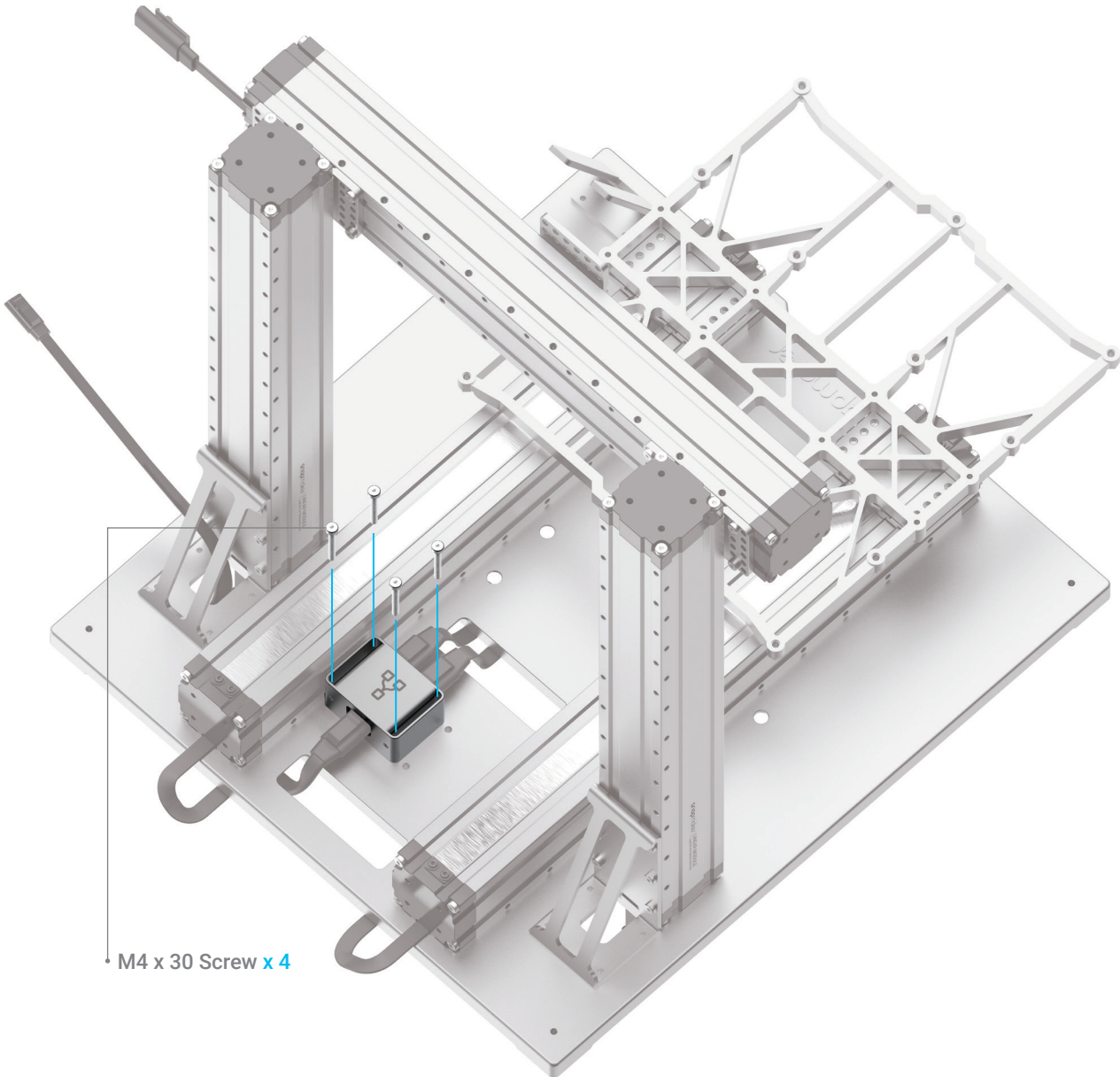
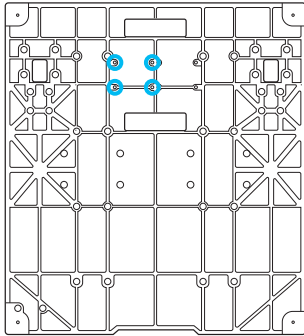

M4 x 30 Screw x 4

19/24

Locate the Z Conversion Cable, and the attached cable on both of the two Z Axes as illustrated. Connect them to the Converter.

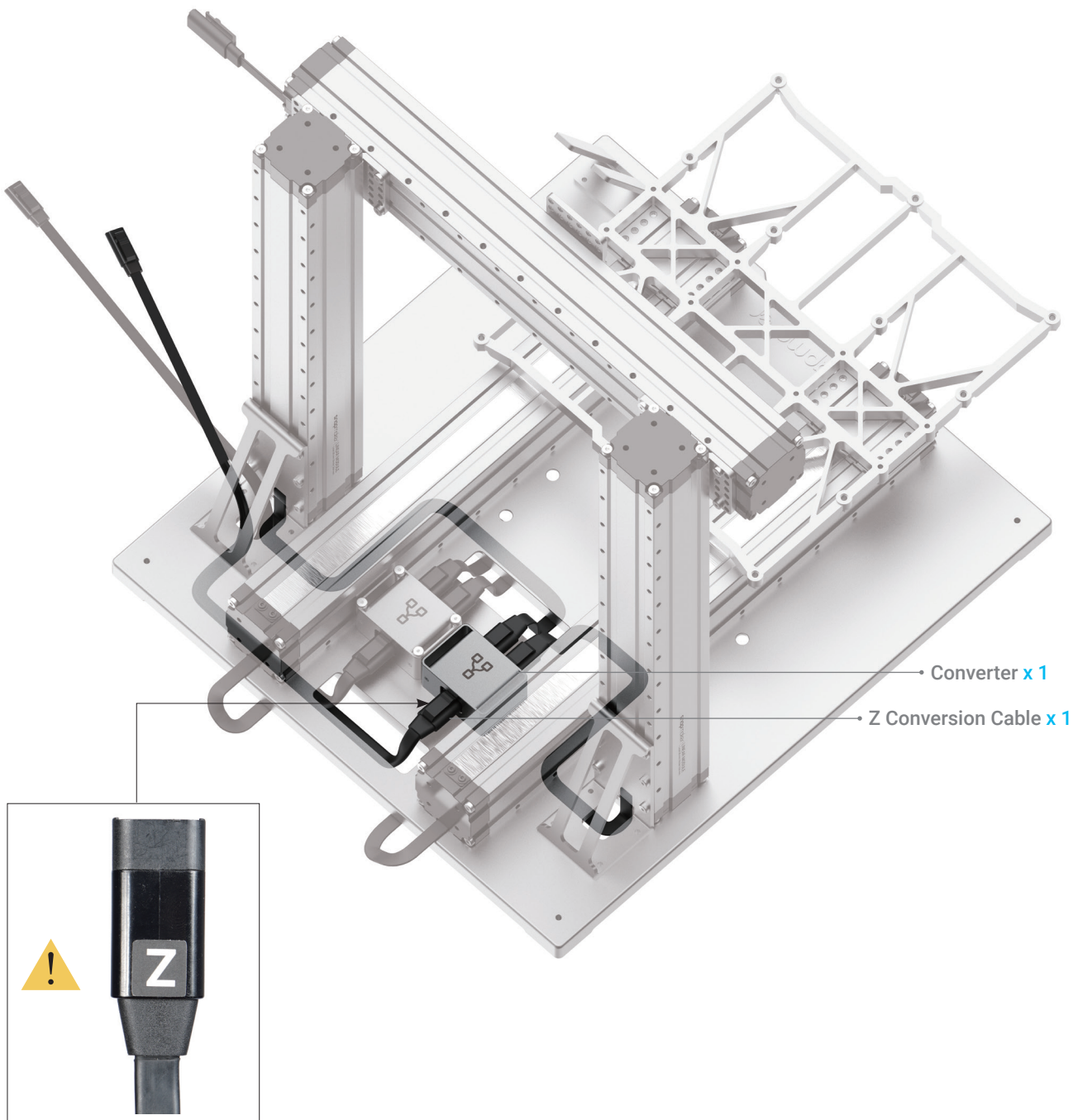

21/24

Attach the Controller to the Z Axis.

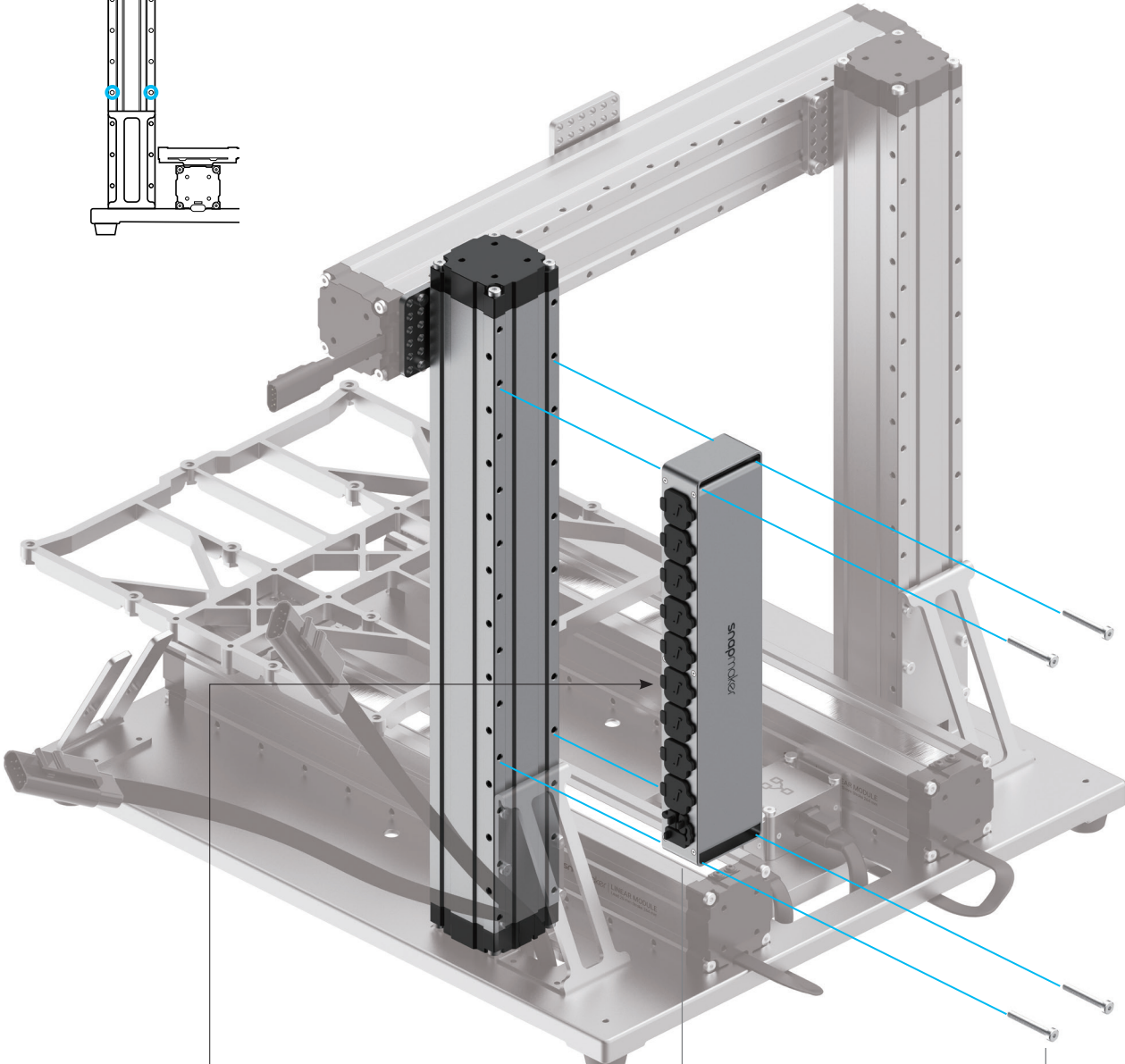
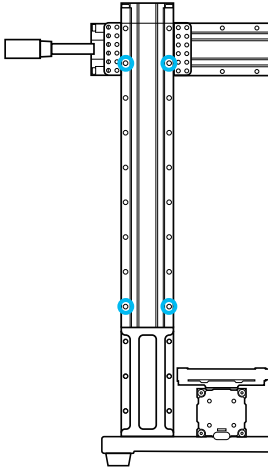

Controller x 1

M4 x 30 Screw x 4

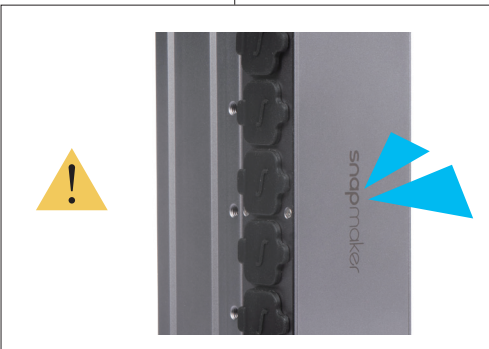

Open the dust plugs, and then connect the X, Y and Z Axes with the Controller.

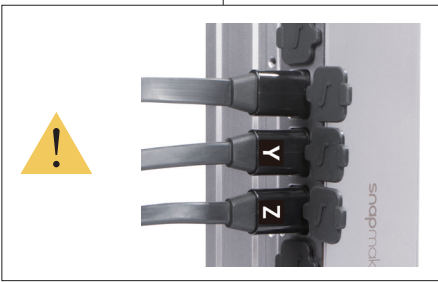
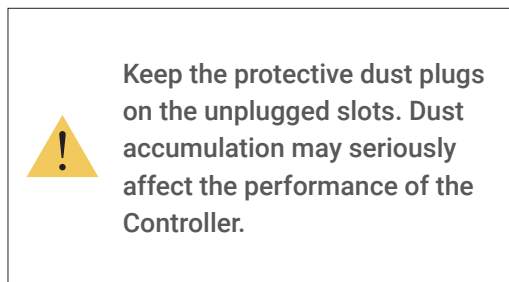
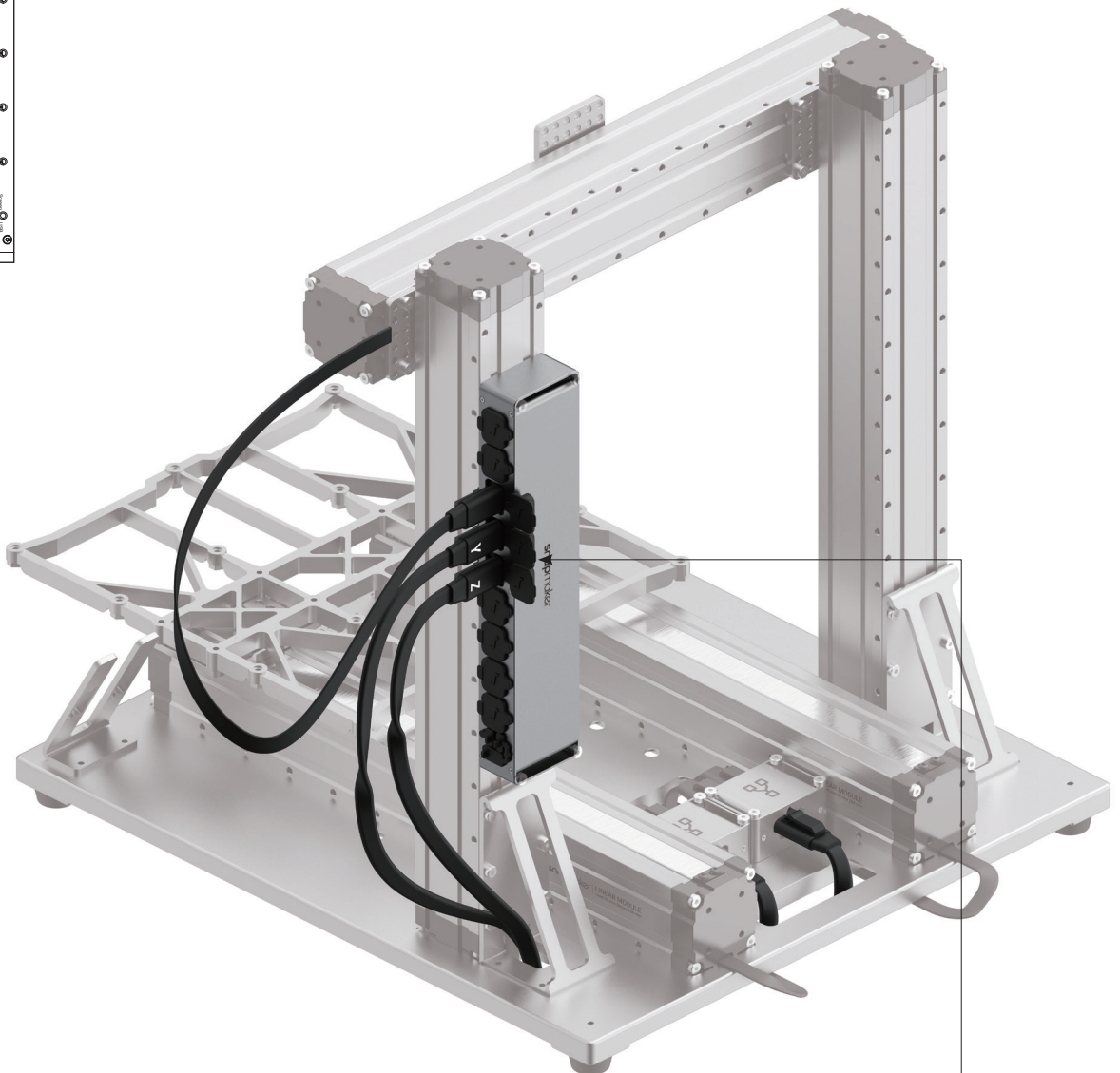
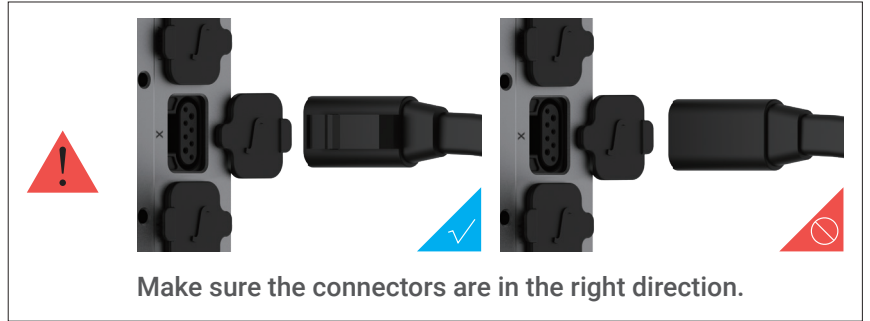
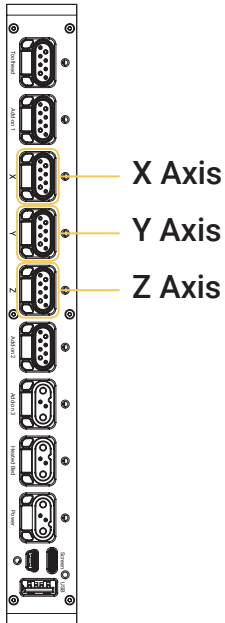

23/24

Place the Touchscreen, and then connect the Touchscreen with the Controller.

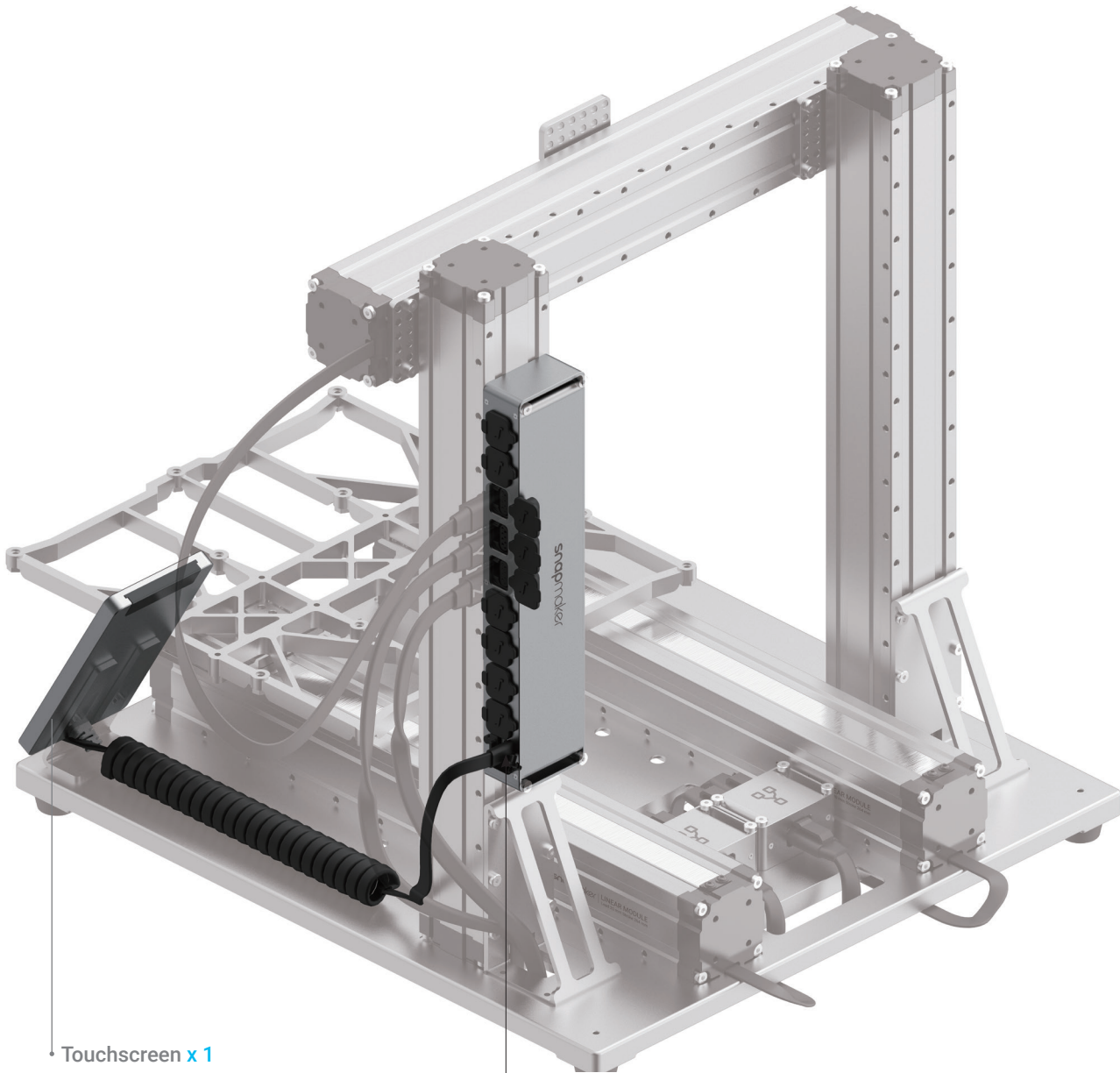

• Touchscreen x 1

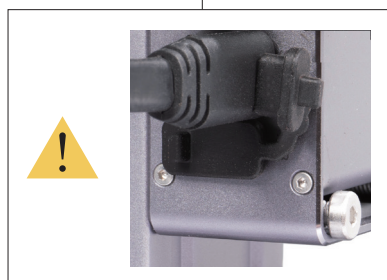

24/24

Connect the cables for the Power Module.

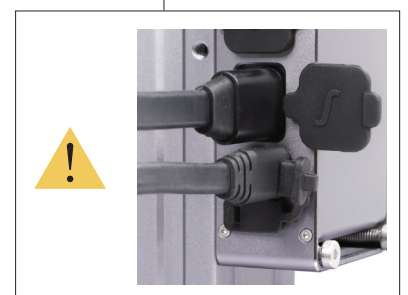
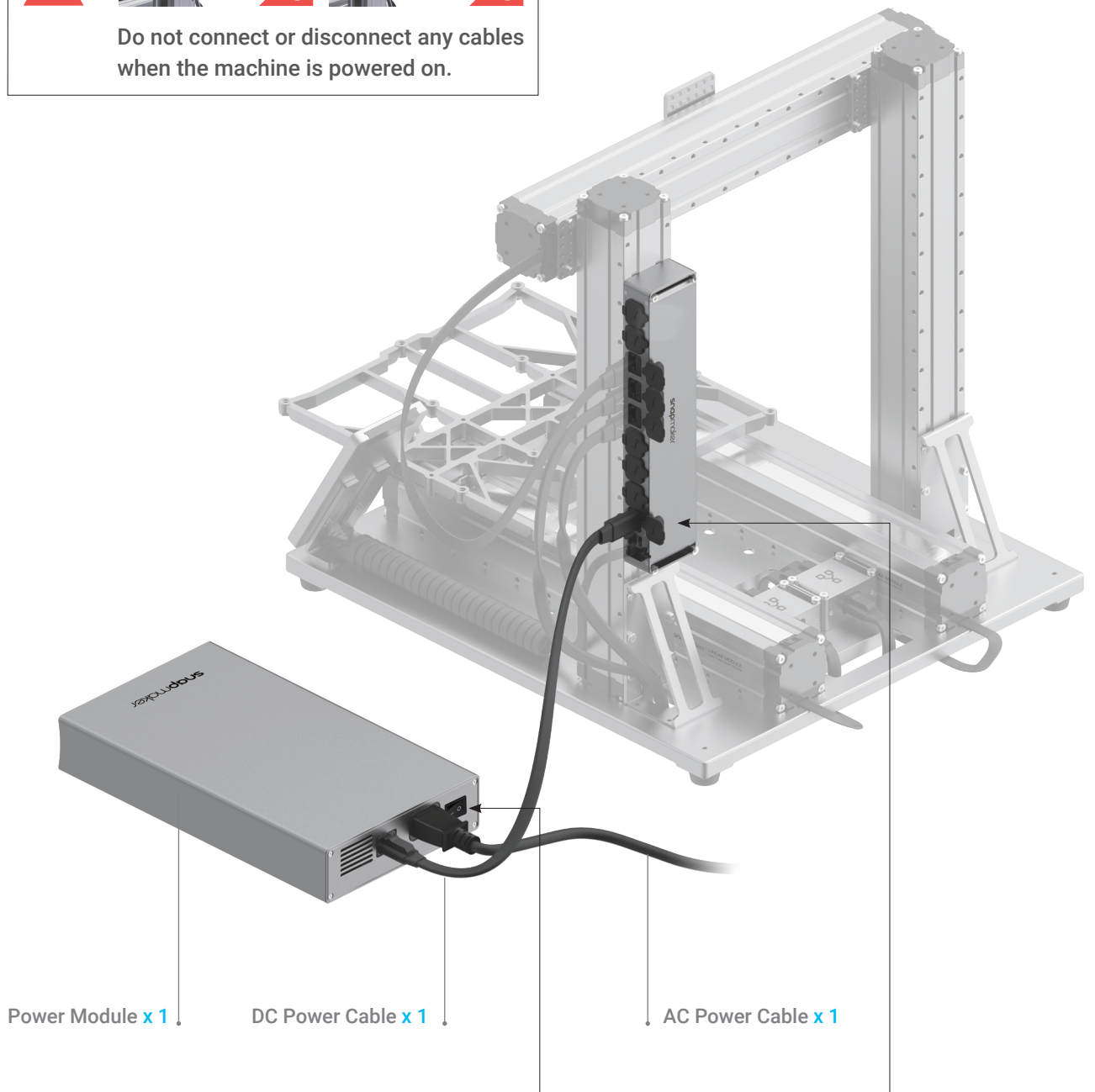

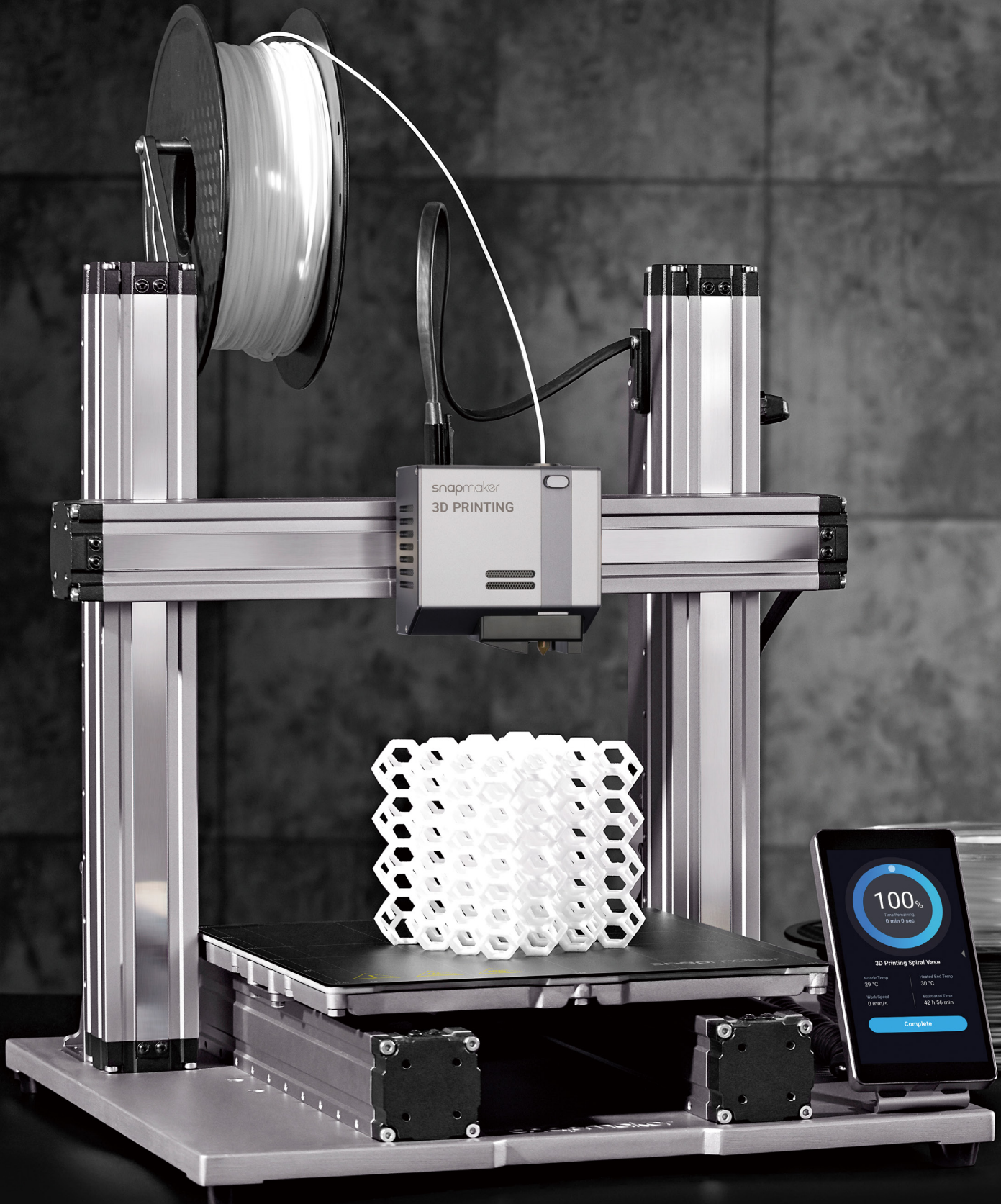

snapmaker
3D PRINTING

100%
Time Remaining
0 min 0 sec

3D Printing Spiral Vase

Nozzle Temp 29 °C	Heated Bed Temp 50 °C
Walk Speed 0 mm/s	Print Speed 42 to 55 mm/s

Complete

3D Printing

3.1 Assembly

3.1.1 Assemble the 3D Printer

3.1.2 Initial Setup

3.2 Get Started

3.2.1 Calibrate the Bed

3.2.2 Load Filament

3.3 Start Printing

3.3.1 Prepare the G-code File

3.3.2 Start Your First Print

3.3.3 Remove the Print



3.1.1 Assemble the 3D Printer

Guides & Pictures / Snapmaker

01/07

Attach the 3D Printing Module to the slider on the X Axis.

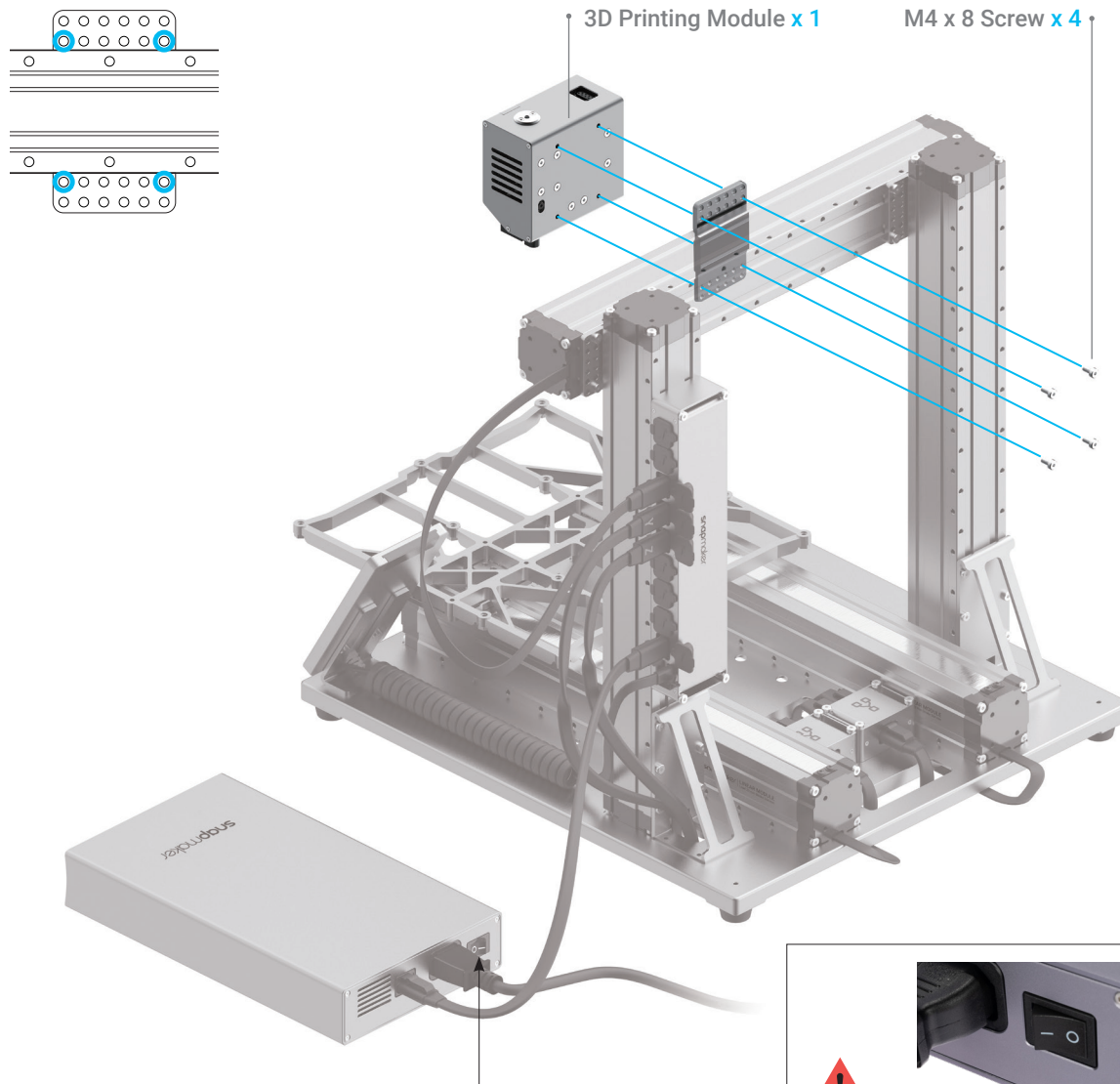

02/07

Connect the 3D Printing Module with the Controller.

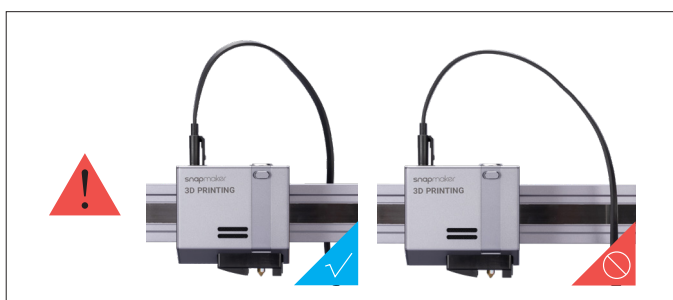
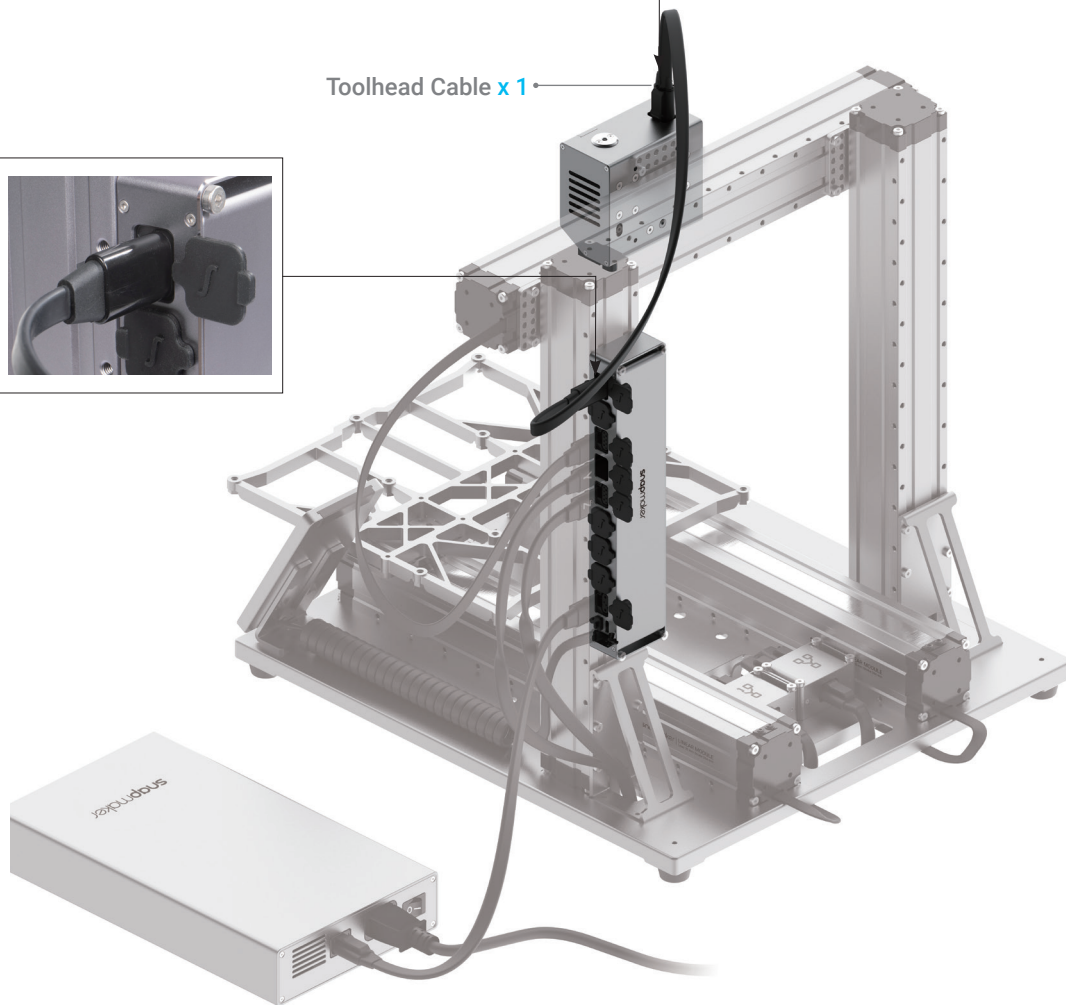

03/07

Attach the Filament Holder to the Z Axis.

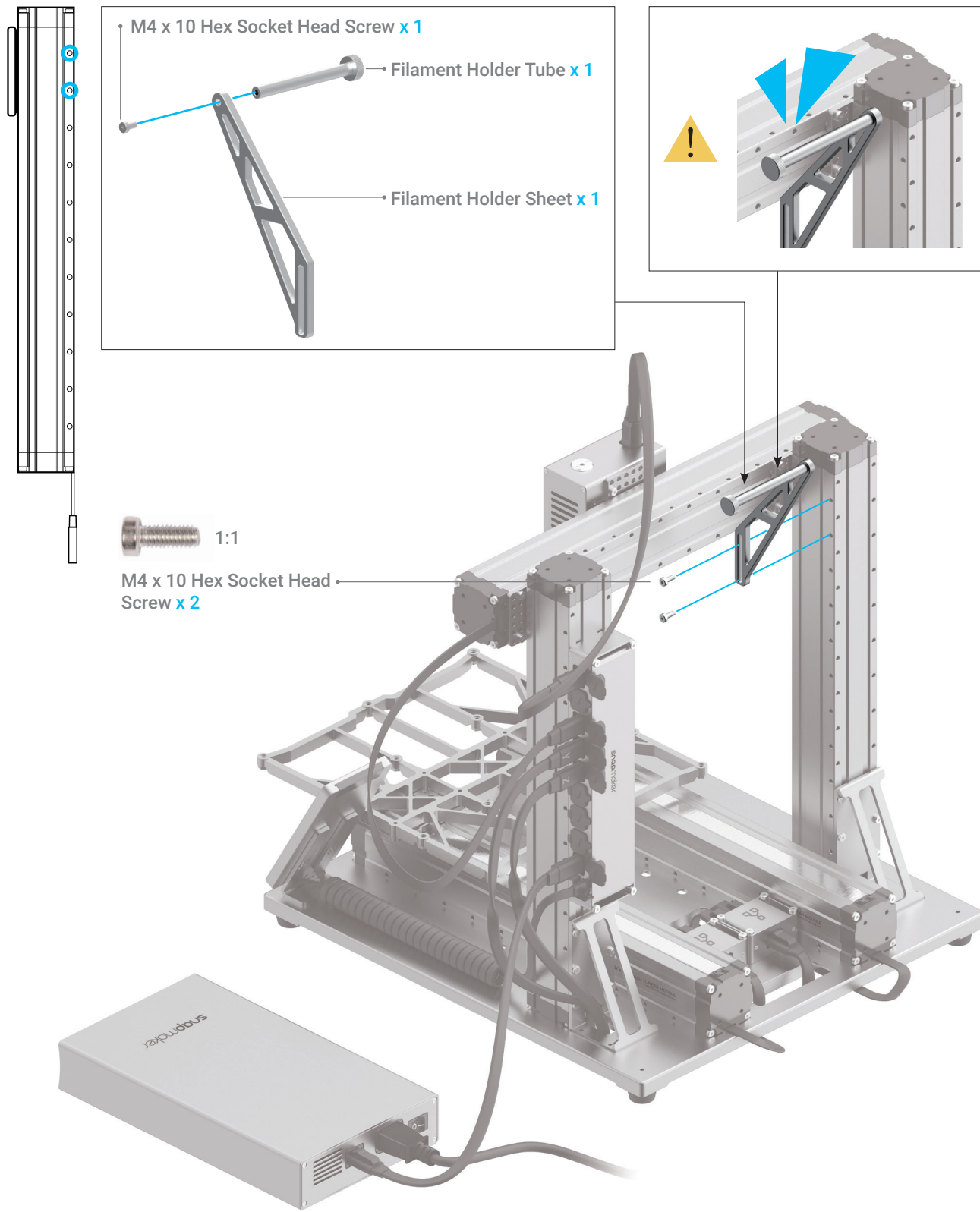

04/07

Attach the Heated Bed to the Platform.

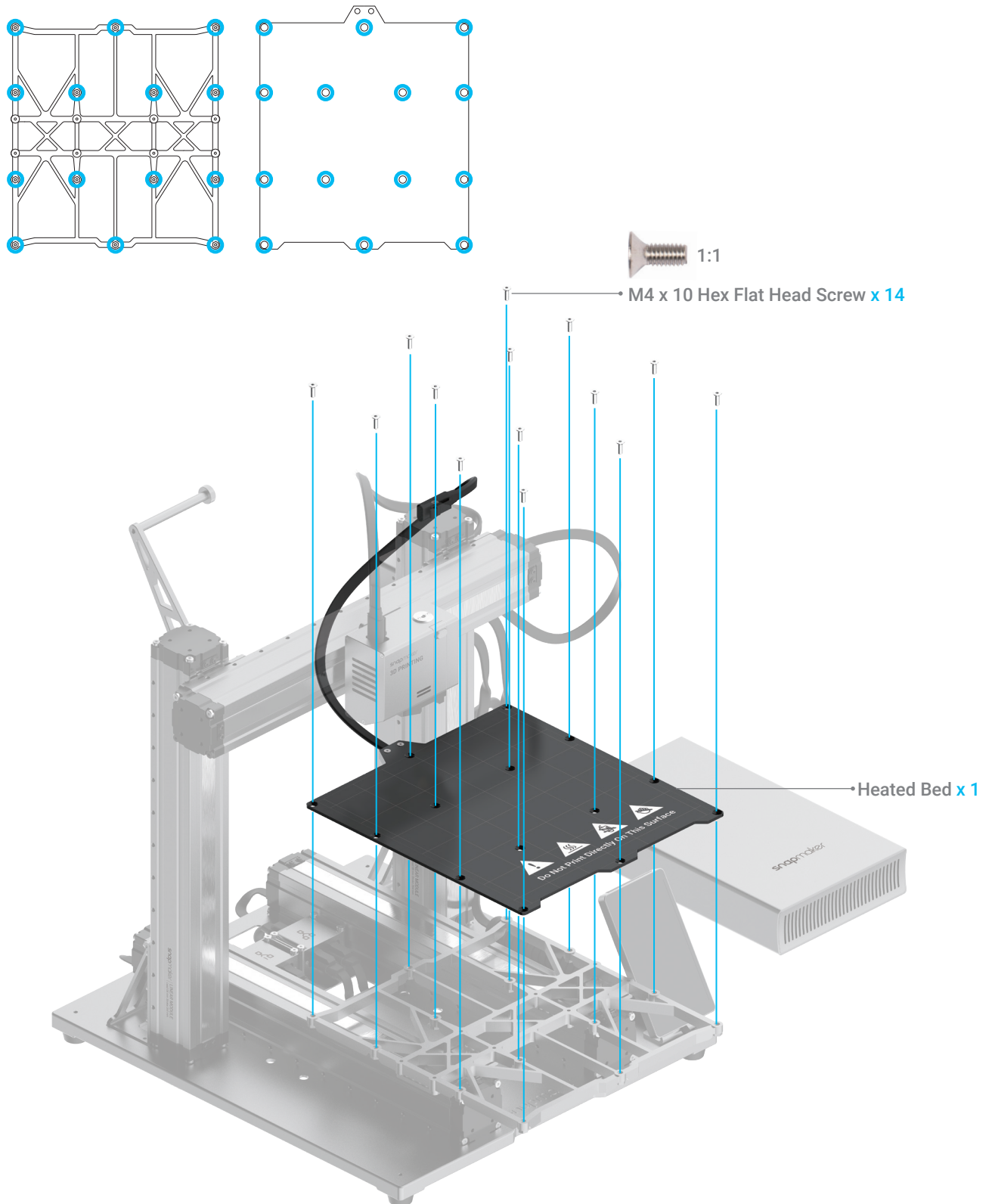

05/07

Place the Print Sheet.



Make sure the Heated Bed is contamination-free before you place the Print Sheet.



Make sure the Print Sheet aligns perfectly with the Heated Bed.

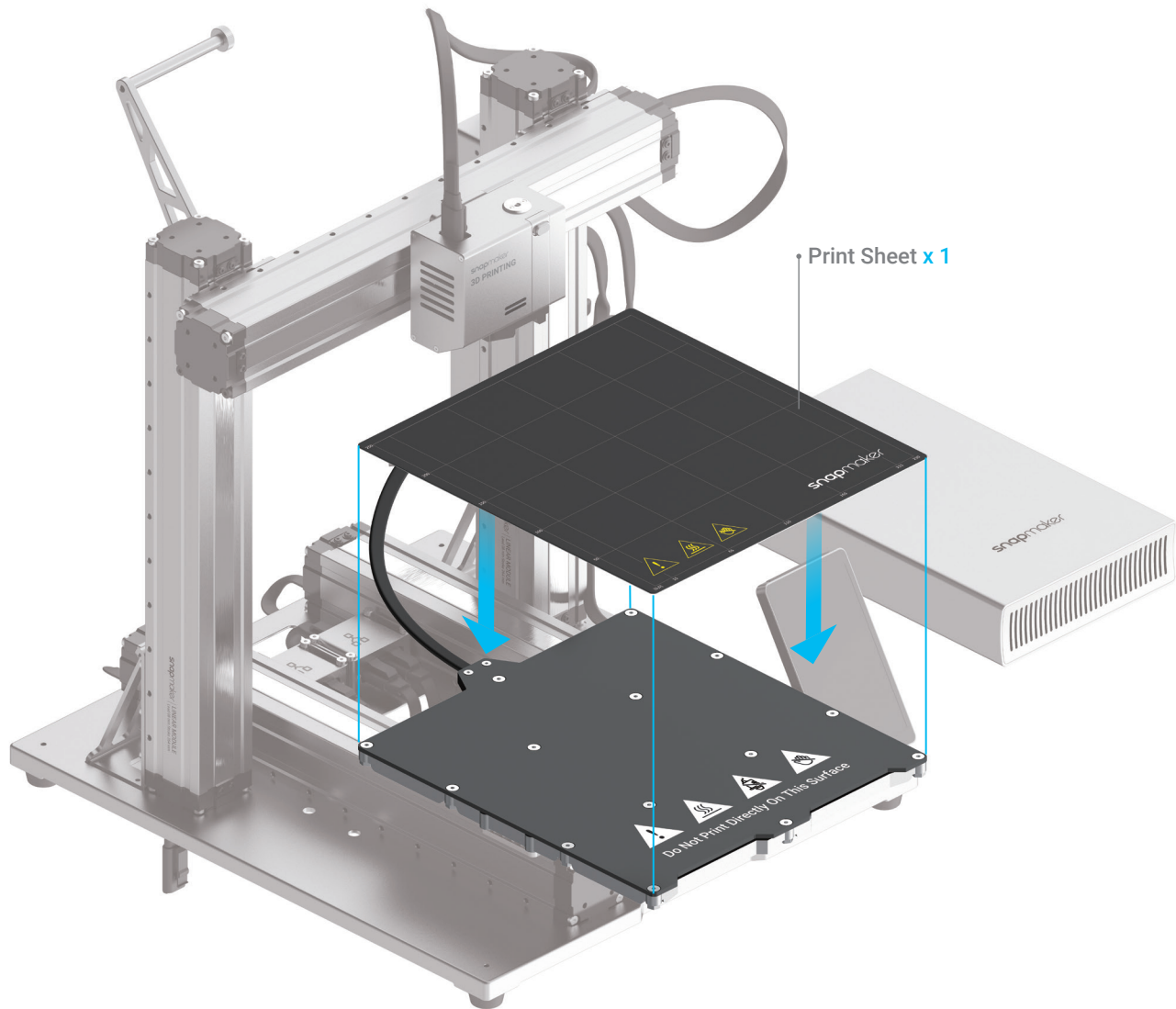

07/07

Attach the Cable Holder to the Z Axis, and then lock the Toolhead Cable into place.

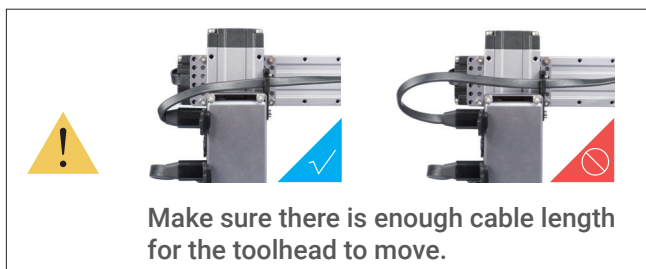
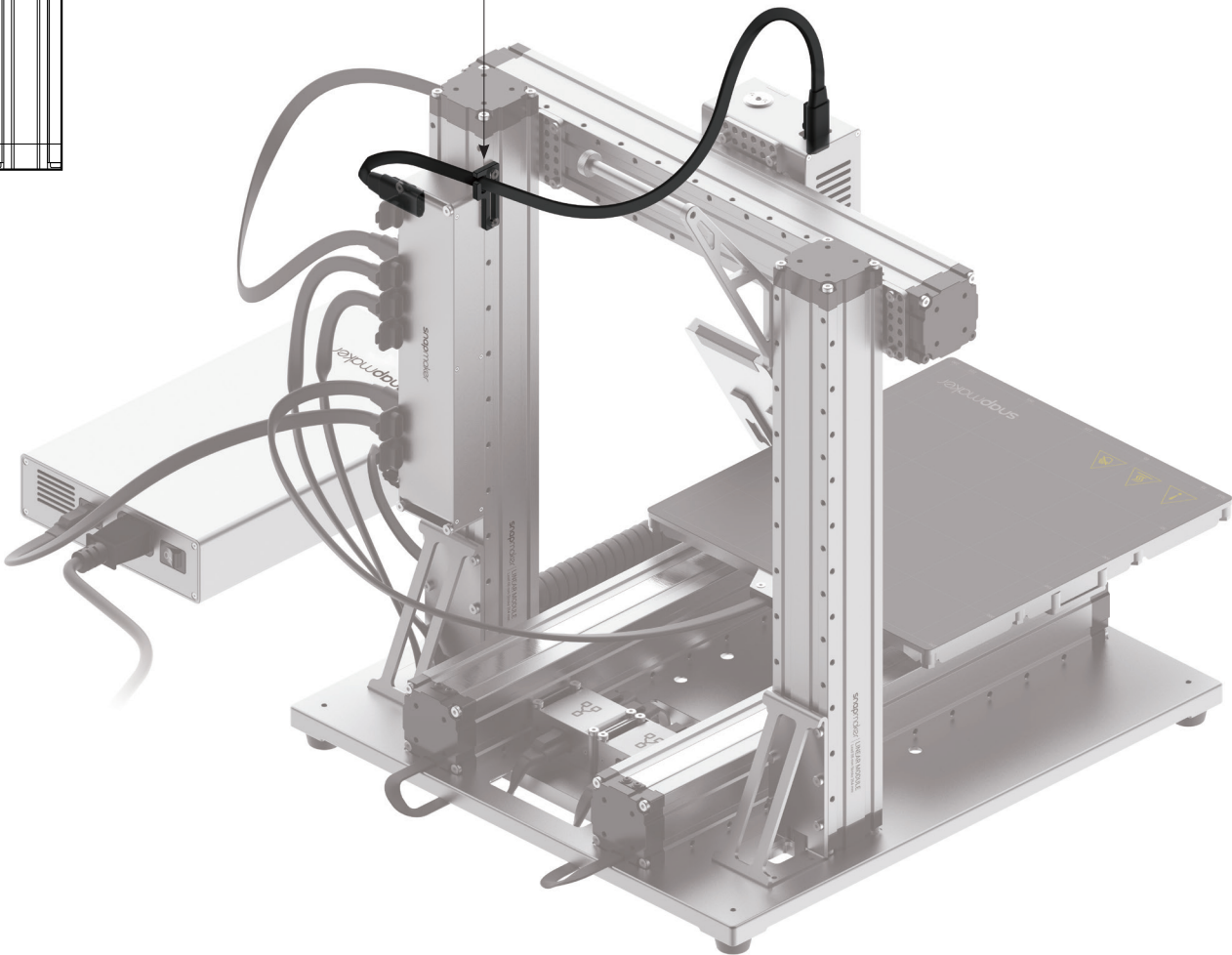
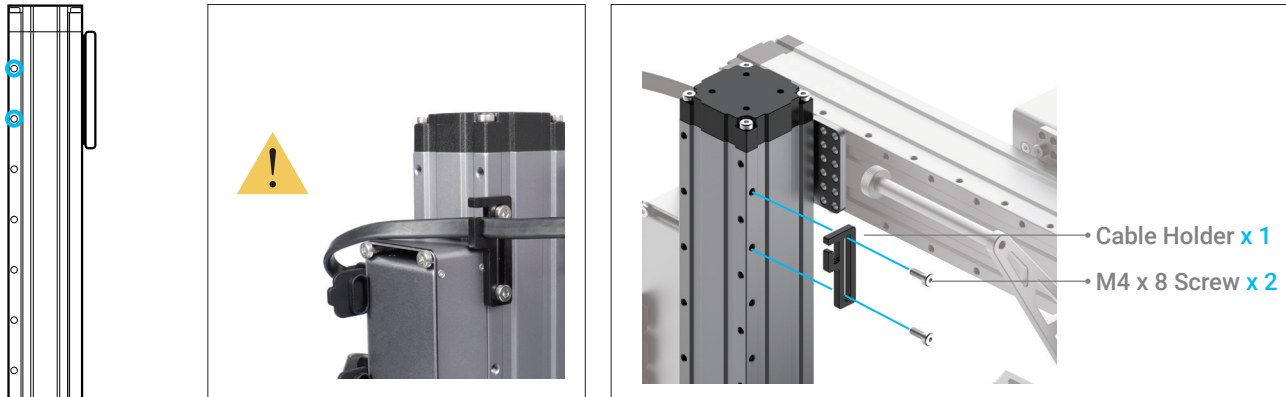

3.1.2 Initial Setup

Guides & Pictures / Snapmaker

Plug the AC Power Cable into an electrical outlet. Switch the power on and follow the prompts on the touchscreen: Read the Terms -> Name the Machine -> Connect to a Wi-Fi Network.



It is recommended to wait for 5 seconds after you restart your machine.

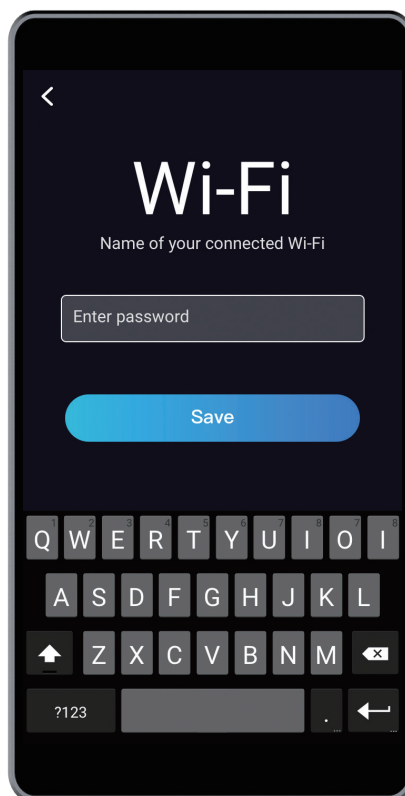
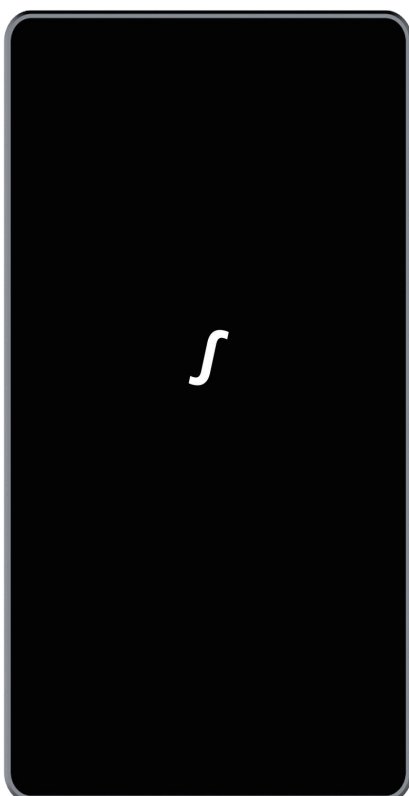

Skip this step if you have completed the initial setup. If you need to change the settings above, swipe left on the homepage of the Touchscreen -> select **Settings** -> tap **Wi-Fi** or **About Machine** as needed.



The initial guide, which helps you get started, will appear only once. If you need to launch it again, swipe left on the homepage of the Touchscreen -> select **Settings** -> tap **Guides**.

3.2.1 Calibrate the Bed

Guides & Pictures / Snapmaker

How It Works: Auto Leveling

The 3D Printing Module conducts a leveling procedure, with the sensor measuring the distance between the nozzle and the Heated Bed at specific points. The movements of the extruder are adjusted to ensure that the nozzle and the Heated Bed are at an optimum distance throughout the printing process.

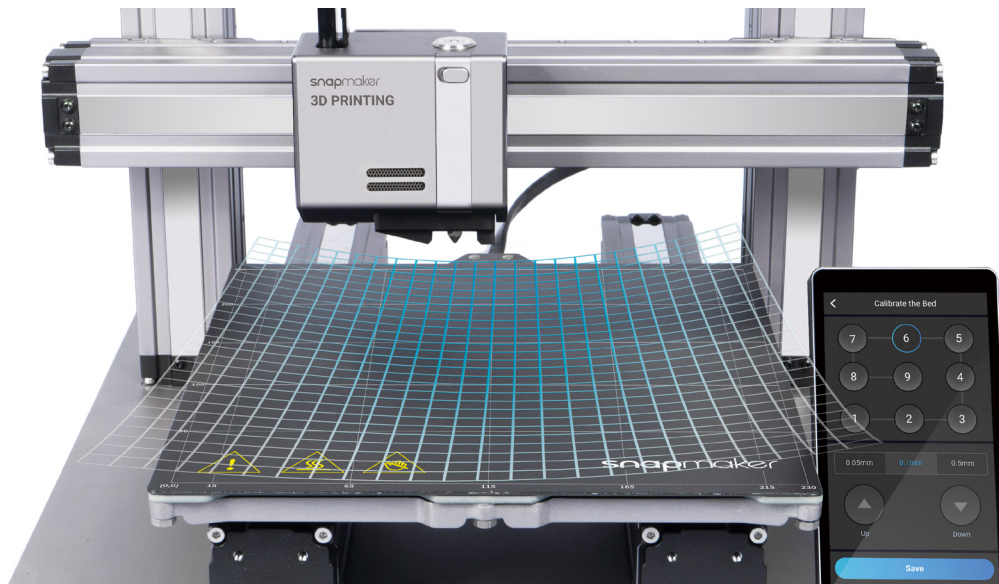

How It Works: Adjusting the Z Offset

Z Offset is the distance between the tip of the nozzle and the print surface. Adjusting the Z Offset is the process of tweaking the height of the nozzle by tiny increments. A proper Z Offset value helps ensure the first layer of your print sticks to the Print Sheet.

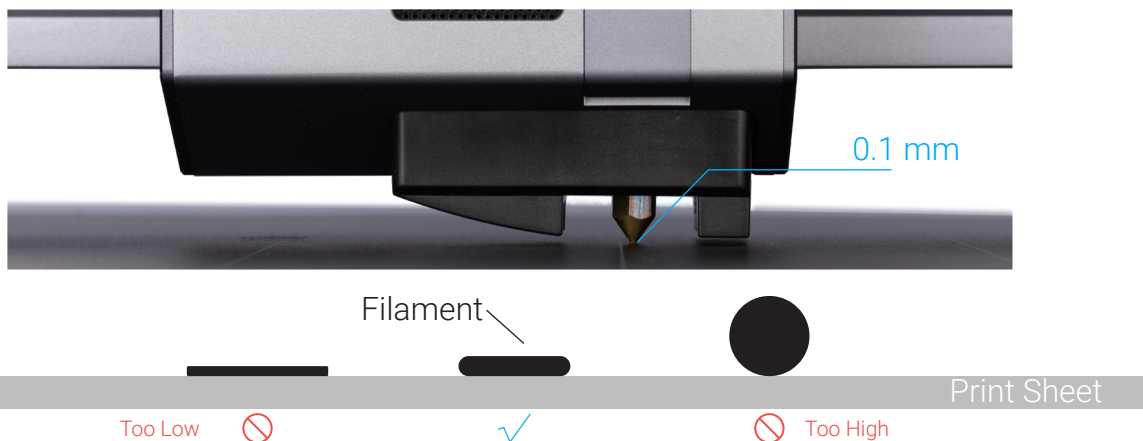

How to Level

1. Run the Auto Leveling procedure on the touchscreen.
2. Place the Calibration Card or a piece of A4 paper between the nozzle and the Heated Bed, and manually calibrate the Z Offset for the last point.



3. Keep adjusting the height of the nozzle using **Up** and **Down** buttons, until you feel slight resistance when you pull out the Calibration Card, and it should be wrinkled when you push it forward. Tap **Save** to save the calibration settings.

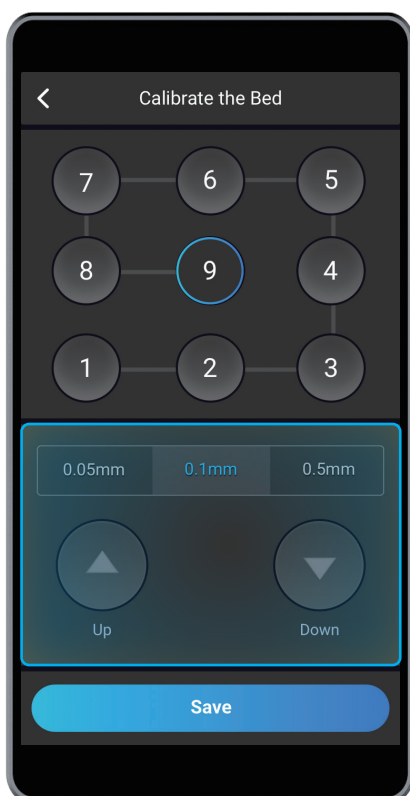

3.2.2 Load Filament

Guides & Pictures / Snapmaker

How It Works: Filament Loading

The motor drives the filament into the extruder, where the filament extrudes through the nozzle after being heated by the heated block.

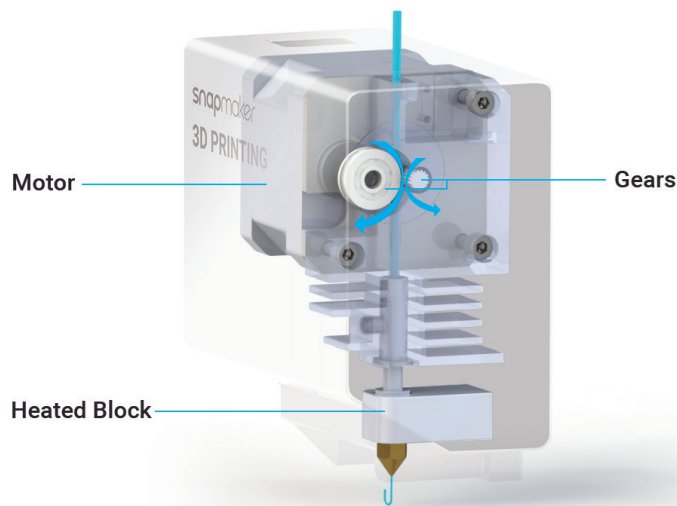

How to Load Filament

1. Hang the provided PLA filament over the Filament Holder. Cut the bending end of the filament using the diagonal pliers, and then insert the filament into the 3D Printing Module.

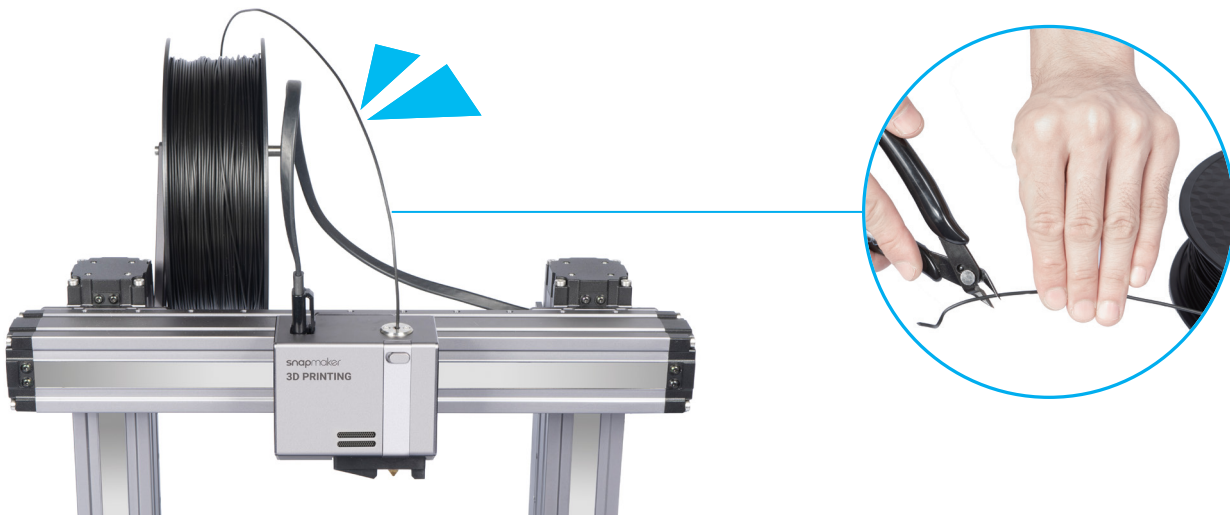

2. Tap **Start** on the **Load Filament** screen. After the temperature reaches the target temperature, tap **Load** and then gently push the filament into the 3D printing module until you can feel the motor pulling the filament in.

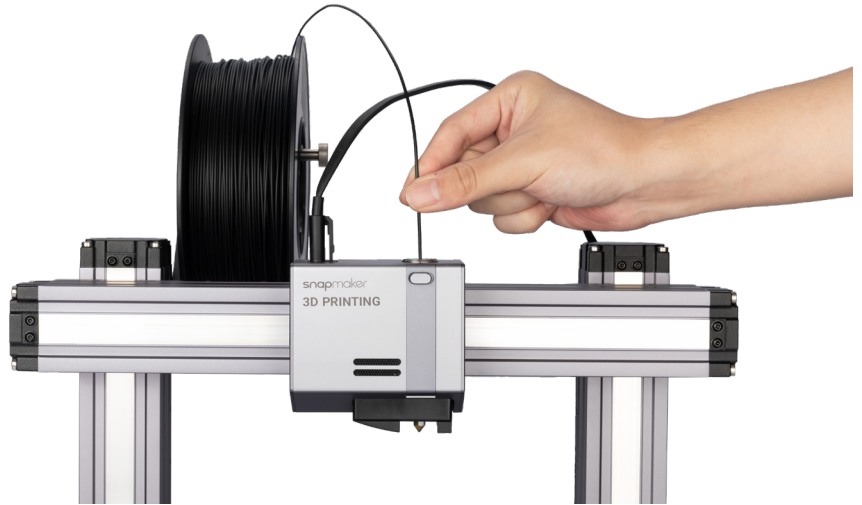

You can change the target **Nozzle Temp** by sliding the scale bar.

3. Clean the nozzle using the tweezers, and tap **Done**.

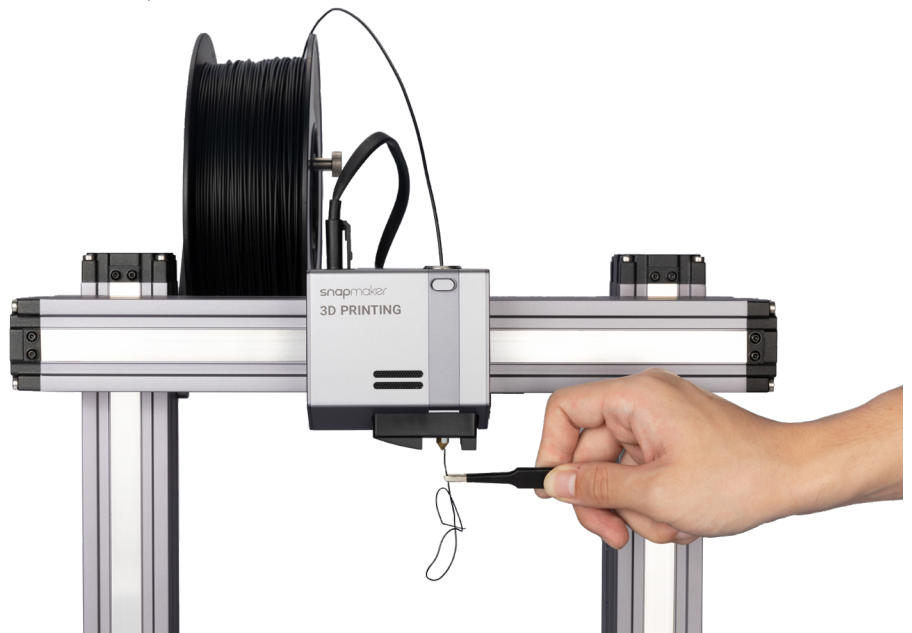

If no filament is coming out of the nozzle, do not tap **Done** until you repeat the steps above and the filament extrudes successfully.



Congratulations!

You are now ready to print. Please continue to generate the G-code file.



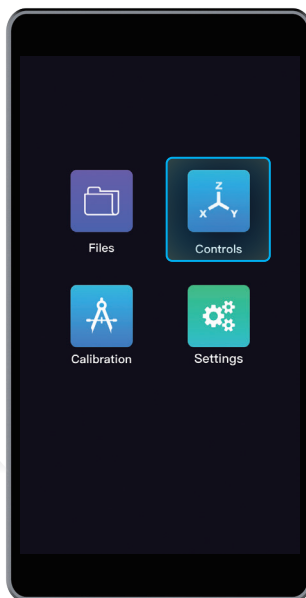
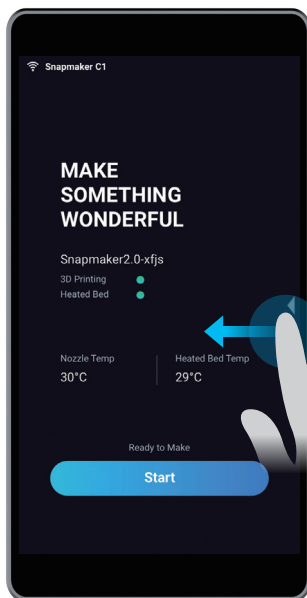

When you need to change the filament, select **Controls** and **Nozzle**. After the temperature reaches the target temperature, tap **Unload** and pull the filament out of the module.



3.3.1 Prepare the G-code File



Guides & Pictures / Snapmaker

1. Install the Software and Complete the Initial Setup

Download our software the Snapmaker Luban at <https://www.snapmaker.com/download> and install. Then connect Snapmaker Luban to your machine through the same Wi-Fi network: Enter **Workspace**  -> **Connection** -> Select **Wi-Fi** -> Click **Refresh**  -> Select your machine -> Click **Connect** -> Tap **Yes** on the Touchscreen.

2. Generate the G-code File and Send It to the Machine

① Click **Back** to return to **Home** -> ② Open the test file from **Case Library** -> ③ Use the default settings specifically configured for the test file -> ④ Generate the G-code file -> ⑤ Load G-code to Workspace -> ⑥ Send G-code to the machine via Wi-Fi.

 You can also upload your own files by clicking  and configure the file settings.

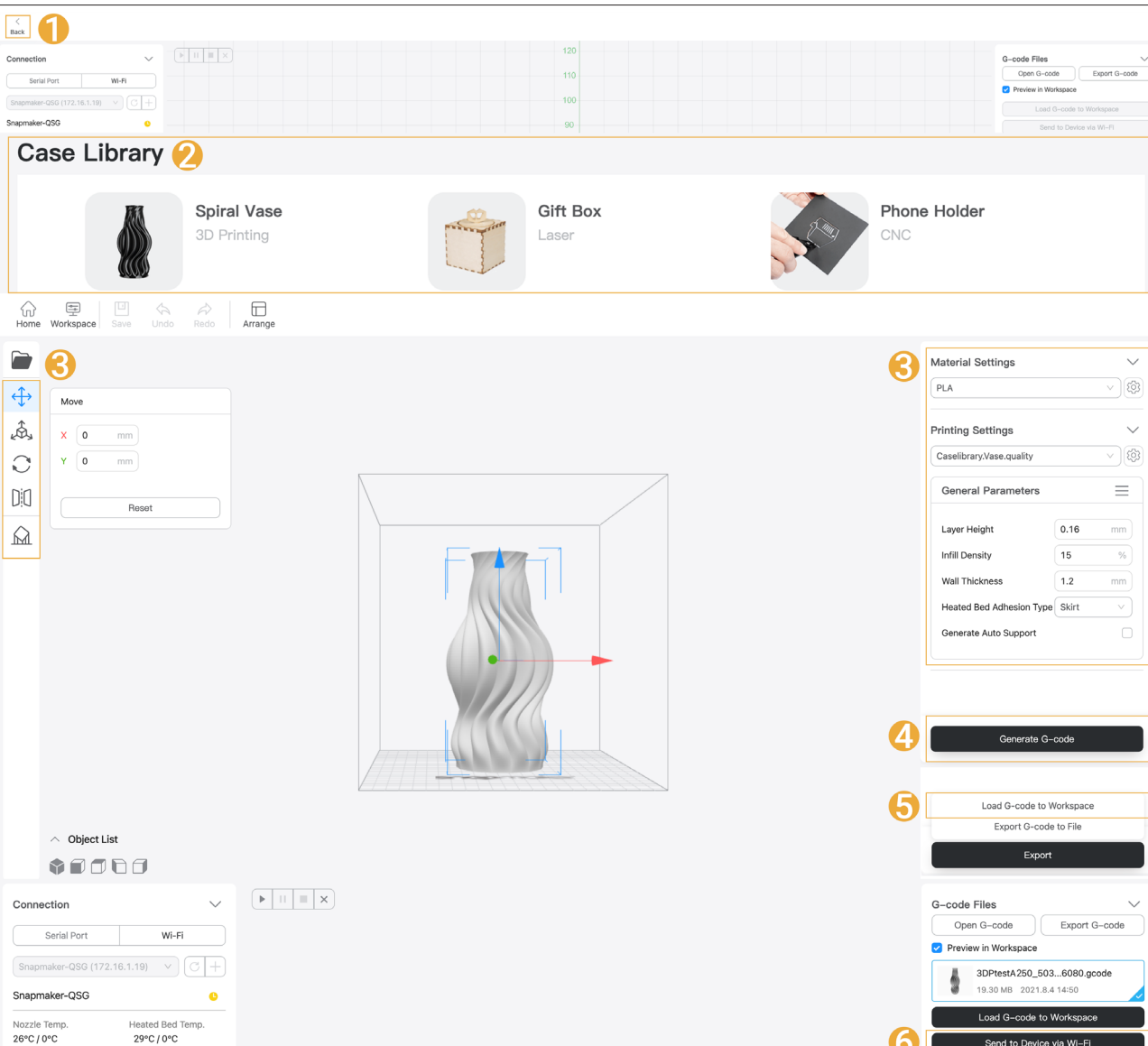

The screenshot shows the Snapmaker Luban software interface. At the top, there's a 'Case Library' section with three items: 'Spiral Vase' (3D Printing), 'Gift Box' (Laser), and 'Phone Holder' (CNC). The 'Spiral Vase' is selected. Below this is a 3D preview of the vase in a workspace. To the right, there are 'Material Settings' (PLA) and 'Printing Settings' (CaselibraryVase.quality). A 'Generate G-code' button is highlighted with a '4'. Below it, 'Load G-code to Workspace' and 'Export G-code to File' buttons are shown, with 'Export' highlighted with a '5'. At the bottom right, the 'G-code Files' list shows a file named '3DPtestA250_503...6080.gcode' with a 'Send to Device via Wi-Fi' button highlighted with a '6'. The interface also includes a 'Connection' panel at the bottom left showing 'Snapmaker-QSG (172.16.1.19)' connected via Wi-Fi, and a status bar at the very bottom showing 'Nozzle Temp. 26°C/0°C' and 'Heated Bed Temp. 29°C/0°C'.



Files sent by Wi-Fi can be found on the Touchscreen: **Files > Local**.



You can also send the G-code file to the machine via the USB disk. For detailed instructions, refer to our **Snapmaker Luban User Manual**.

3.3.2 Start Your First Print

Guides & Pictures / Snapmaker

After receiving the G-code file, tap **Disconnect** on the Touchscreen. Then find and select the received G-code file, and tap **Start** to start printing. The first layer of the print is key to print success. To prevent damage we recommend that you keep an eye on your print, especially while the first layer is being laid out.

If you need to adjust settings, you can either tap **Adjust Settings** prior to printing or swipe left on the printing progress screen.

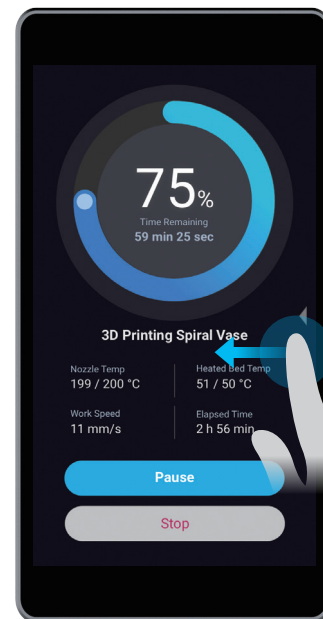
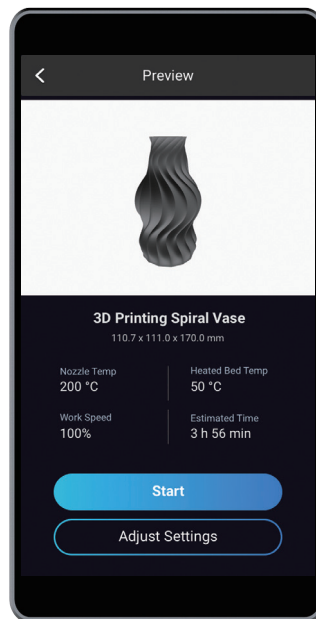

If poor adhesion occurs, swipe left on the printing progress screen and try adjusting the Z Offset. Or you can try leveling the Heated Bed again by selecting **Calibration**. Make sure the tip of the nozzle is clean before you calibrate the bed.

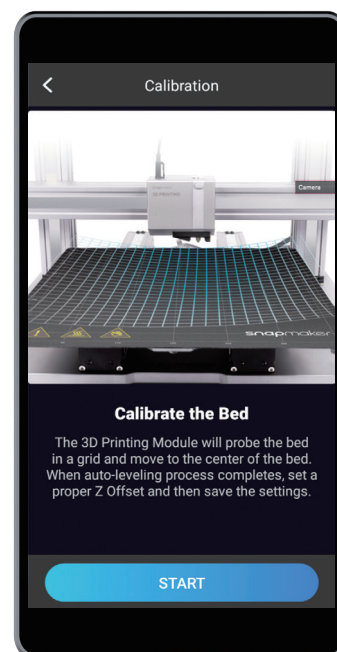
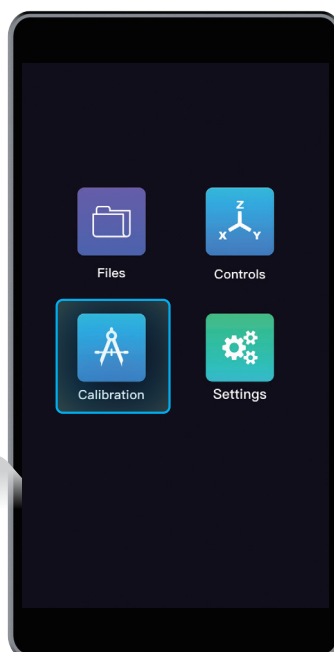
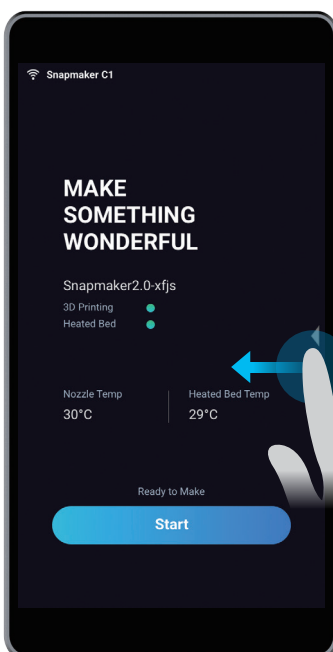

3.3.3 Remove the Print

Guides & Pictures / Snapmaker

Wait for the temperatures of the nozzle and the Heated Bed to drop to room temperature (displayed on the Touchscreen) . Remove the Print Sheet from the Heated Bed and bend it slightly.



The nozzle and the Heated Bed are still extremely hot right after printing.

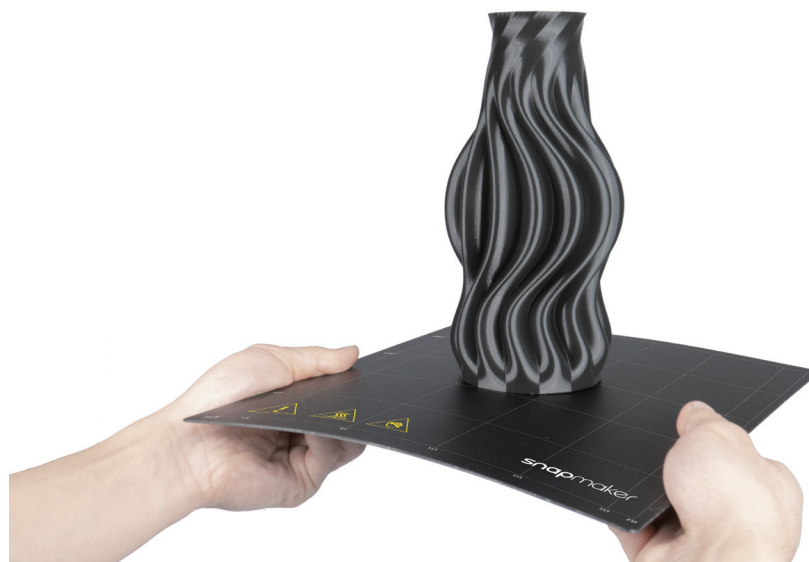
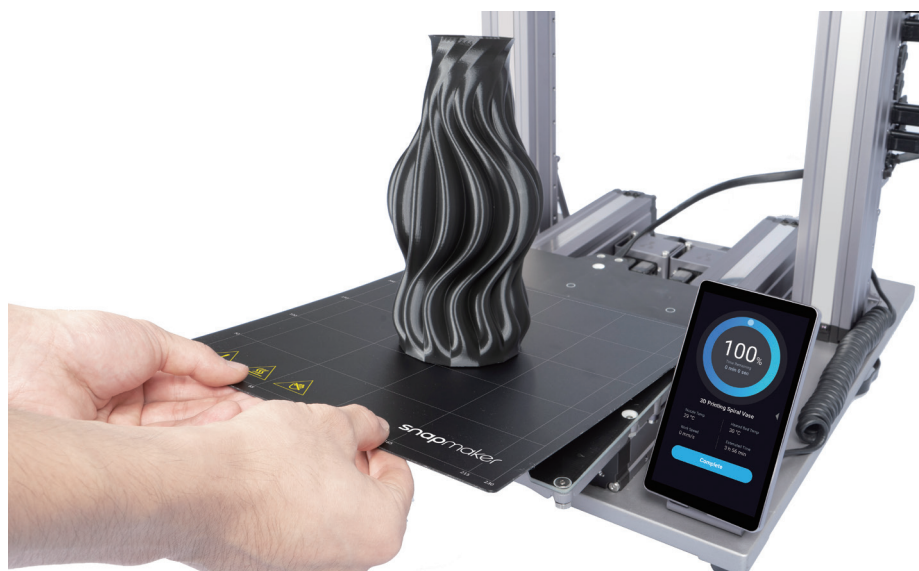



Remove the Print Sheet from the Heated Bed, and place it down on a stable and flat surface. You can also use the palette knife to remove the print.



The palette knife is sharp.



Share!

Share your prints in our Facebook group and our forum.

Filament Runout Recovery & Power-Loss Recovery

Your printer supports filament runout recovery and power-loss recovery, so there is no need to worry about resuming printing anymore! When the filament runs out, tap **Ready to Load** and load new filament to resume printing. In case of power-loss, tap **Recover** to resume printing after the power has been restored.

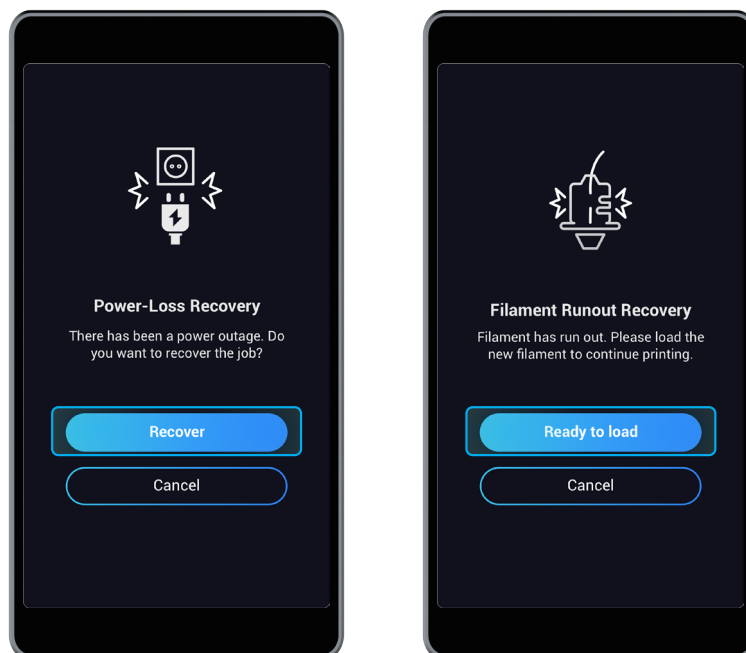

Firmware Update

It is recommended to update the firmware to the most up-to-date version via Wi-Fi or USB flash drive.

📶 : Turn on the machine > Connect your machine to a Wi-Fi network > Swipe left on the Touchscreen > Tap **Settings** > **Firmware Update** > **Check for Updates** > **Update Now** > **Complete**.

🗑️ : Download our firmware from <https://snapmaker.com/product/snapmaker-2/downloads> > Insert the USB flash drive into the Controller > Turn on the machine > Swipe left on the Touchscreen > Tap **Files** > Tap **USB** > Tap the firmware file to update.

Resources

This guide is subject to change. The latest version is on our Support website: Select

Snapmaker 2.0 -> Go to **Quick Start Guide**.

<https://support.snapmaker.com/hc/en-us>

Besides this guide, a User Manual is available on our Support website: Select **Snapmaker 2.0**

-> Go to **User Manual**.

<https://support.snapmaker.com/hc/en-us>

We are here for you whenever you need general information or technical support:

support@snapmaker.com.

For any sales inquiries:

sales@snapmaker.com.

For product purchases:

<https://shop.snapmaker.com>.

Share anything you want with other Snapmaker users in our forum:

<https://forum.snapmaker.com>.



$$\int_0^{\text{Wonderful}} \text{make}(x)dx = \text{snapmaker}$$

Original Instruction

Y.3.B.A.0063 - 01 V1.0.0