

LGR433-S

# Open Closet

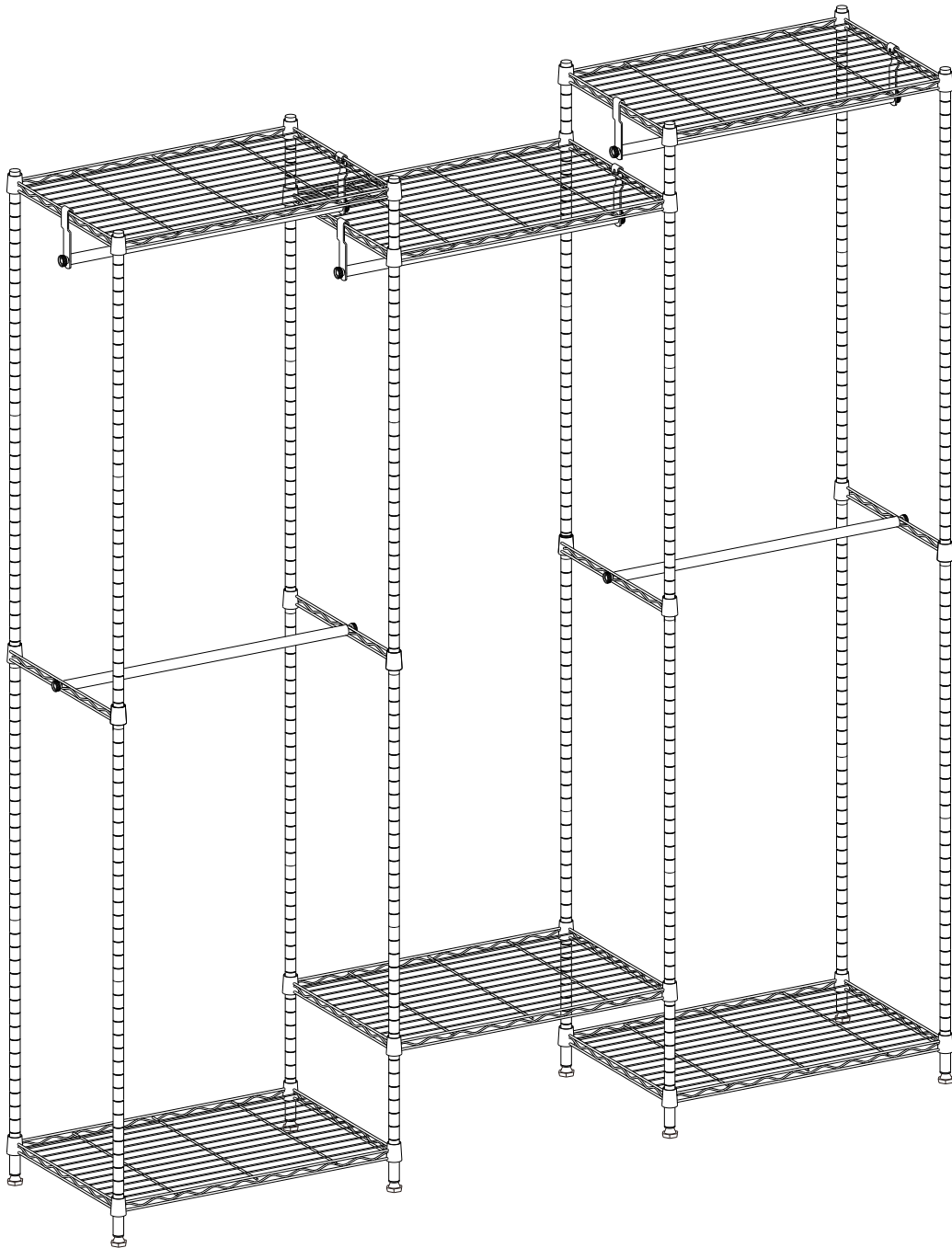

**SONGMICS**  
by SONGMICS HOME

**A** × 6

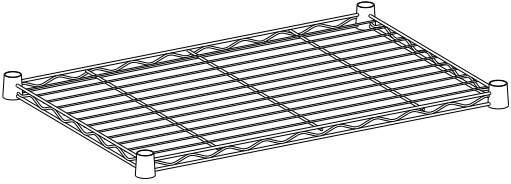

**B** × 8



**C** × 16



**D** × 8

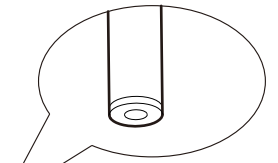
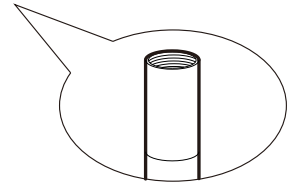

**E** × 4

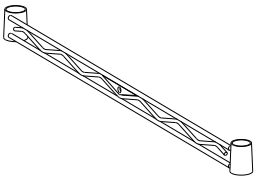

**F** × 5



**G** × 6

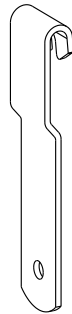

**I** 64+6

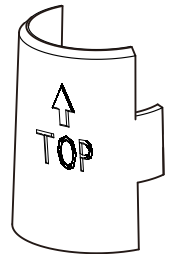

**2** × 10

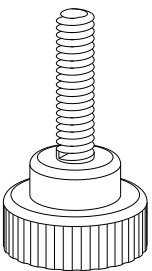

**3** × 8

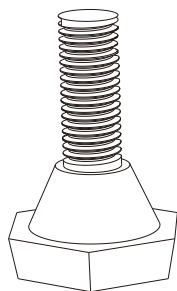

**4** × 2

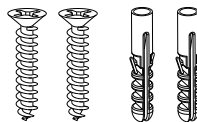
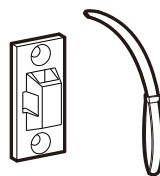

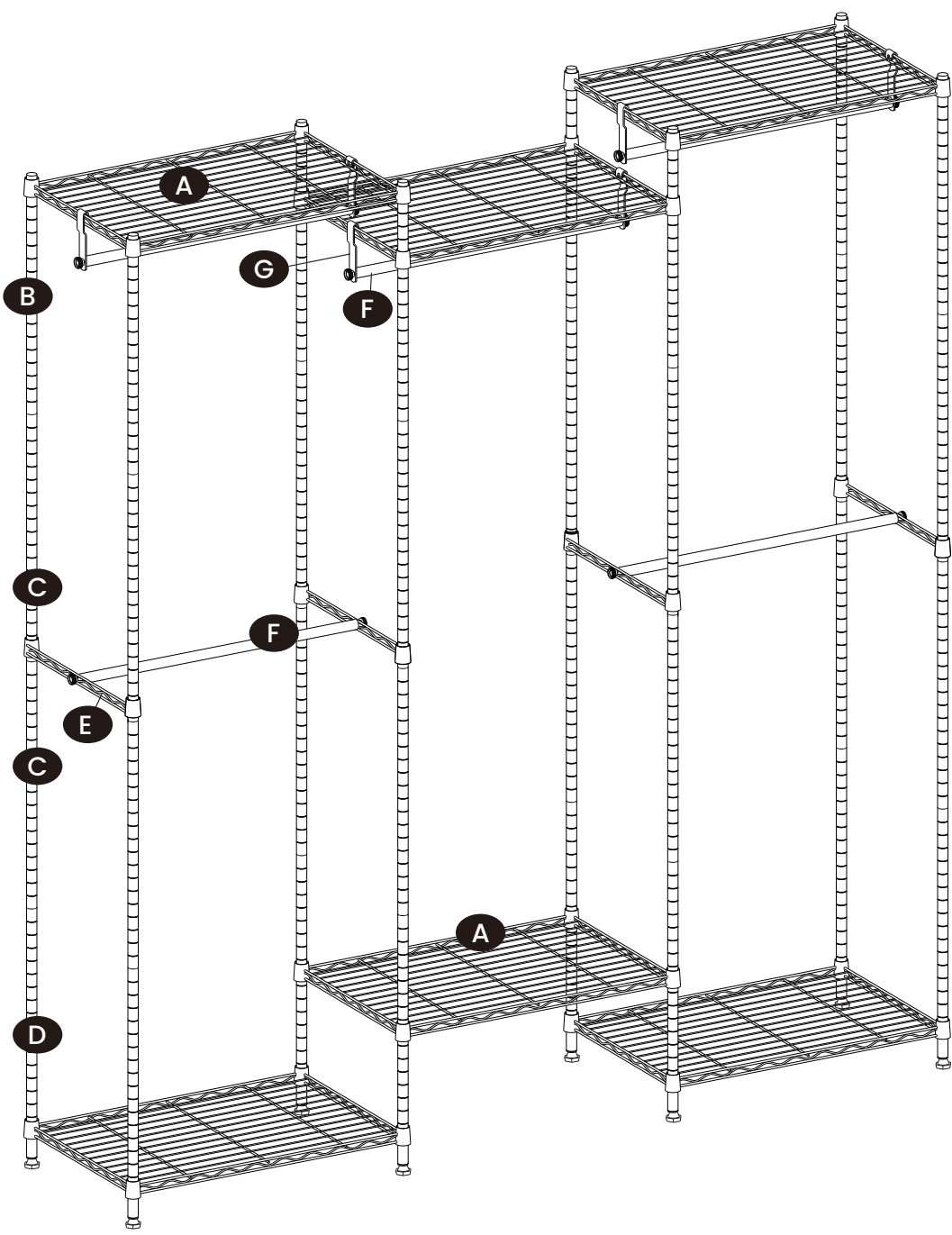
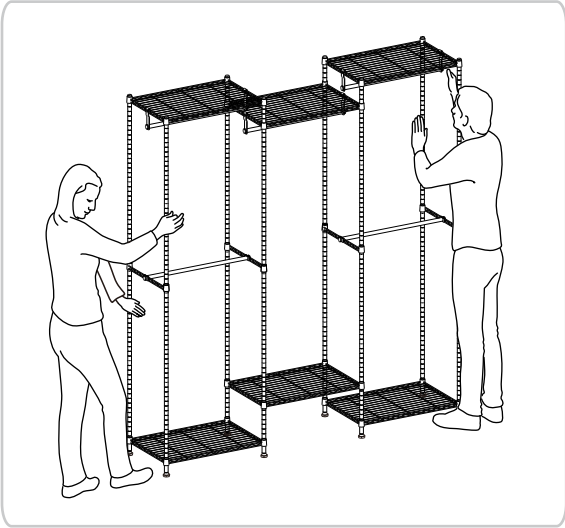

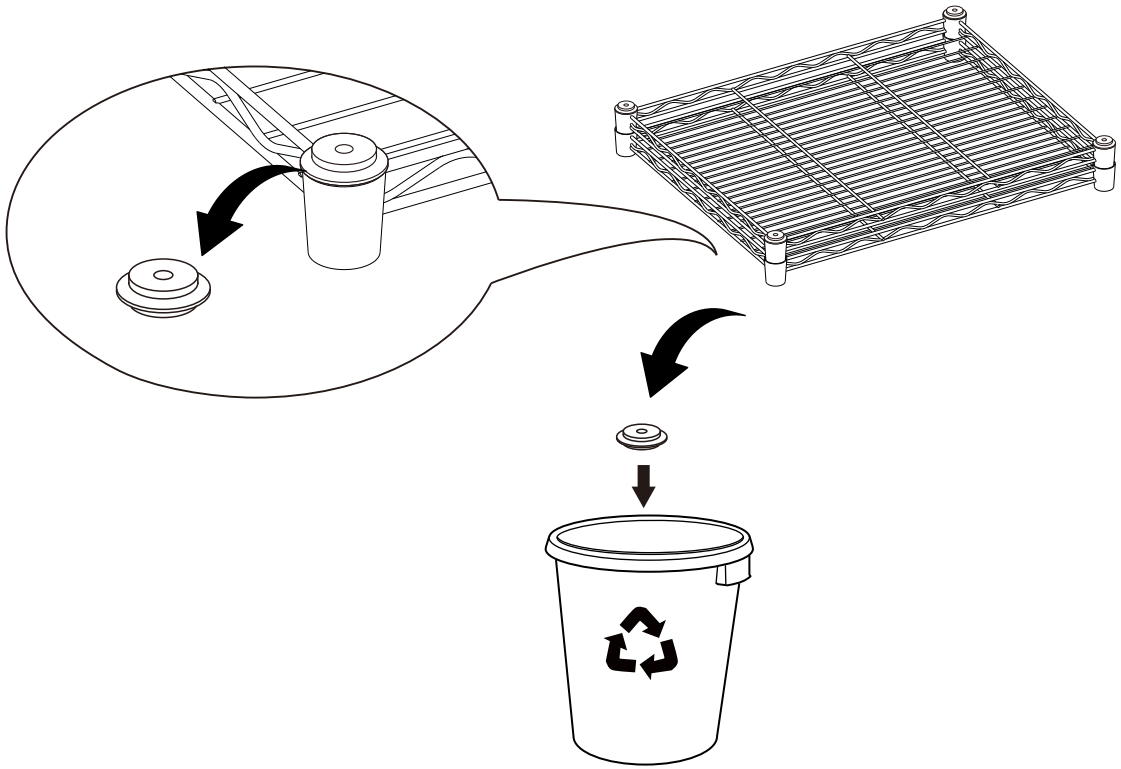

1

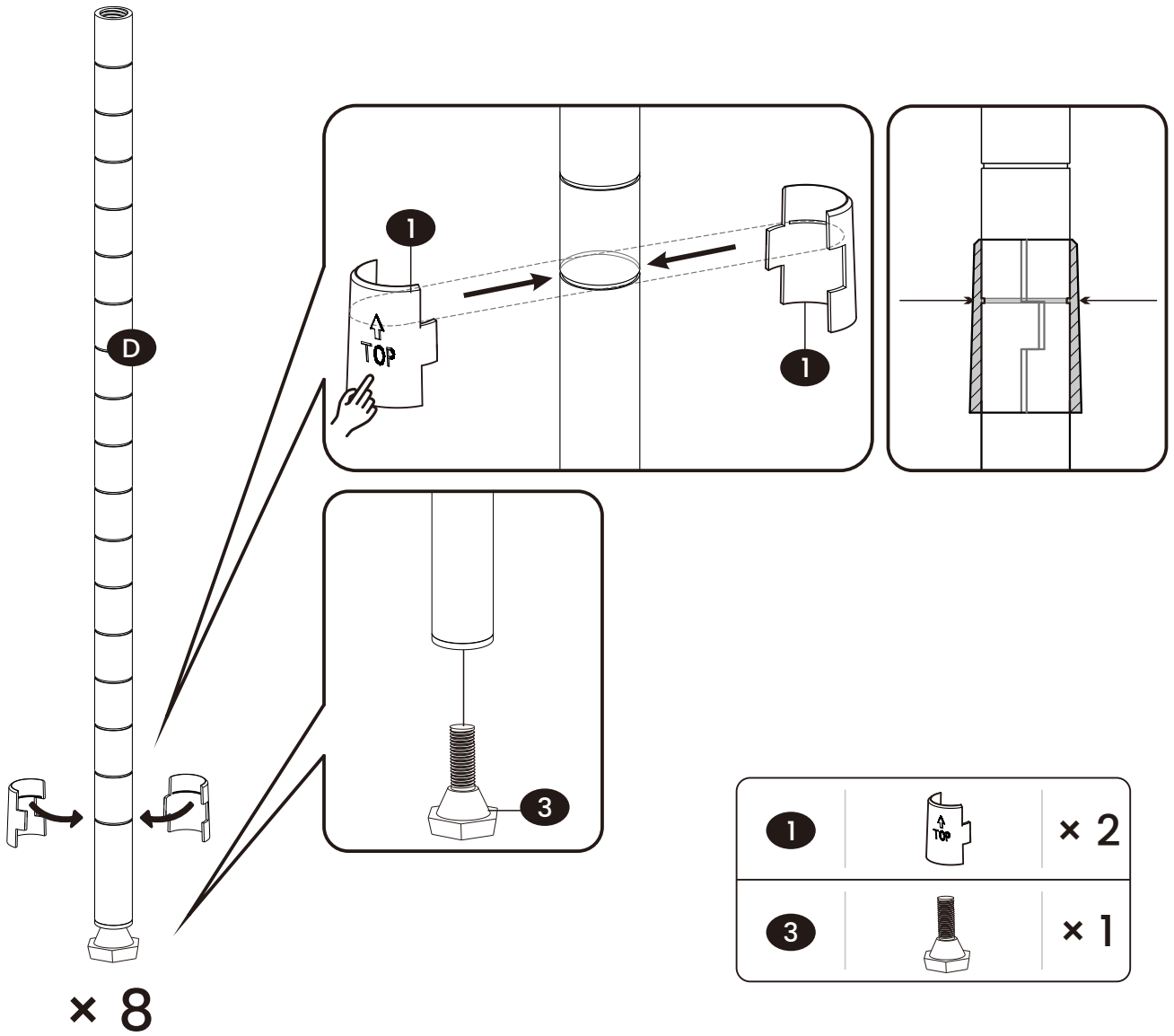

4

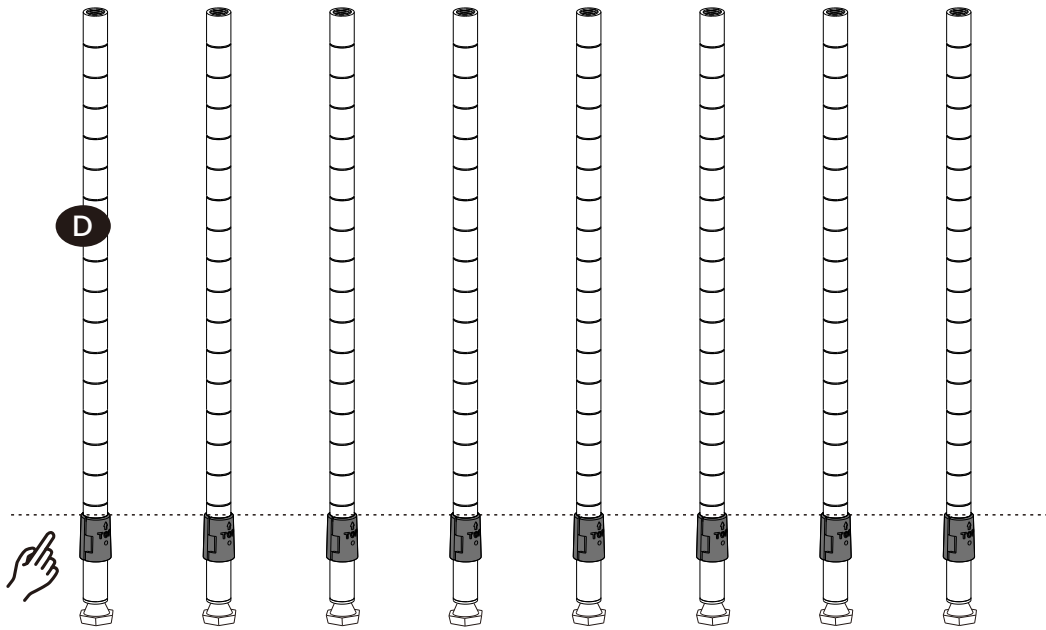

2

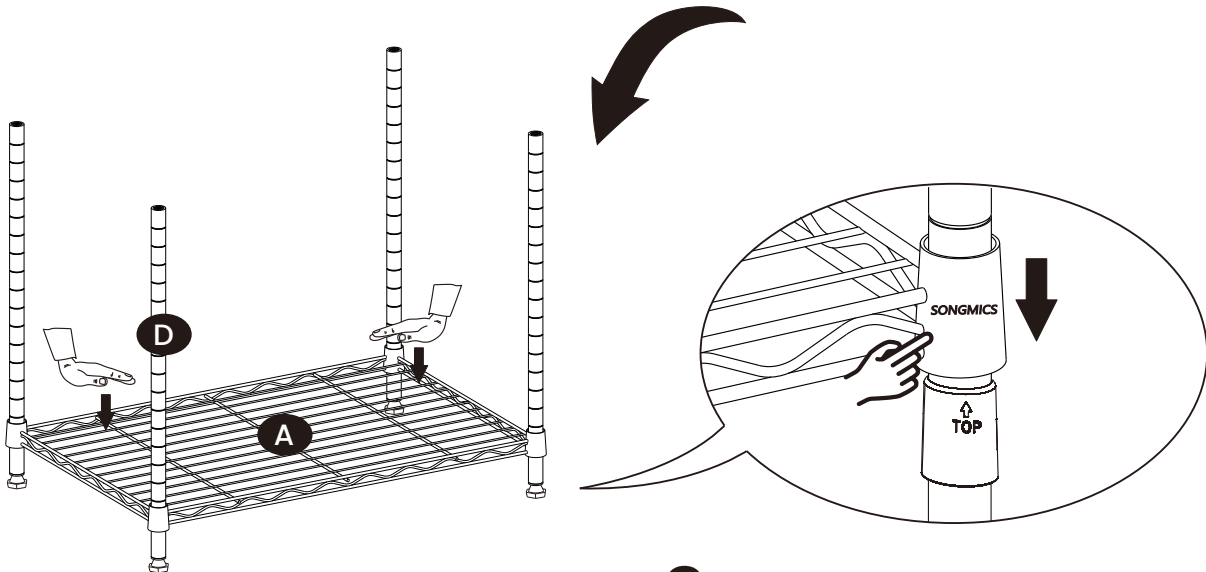
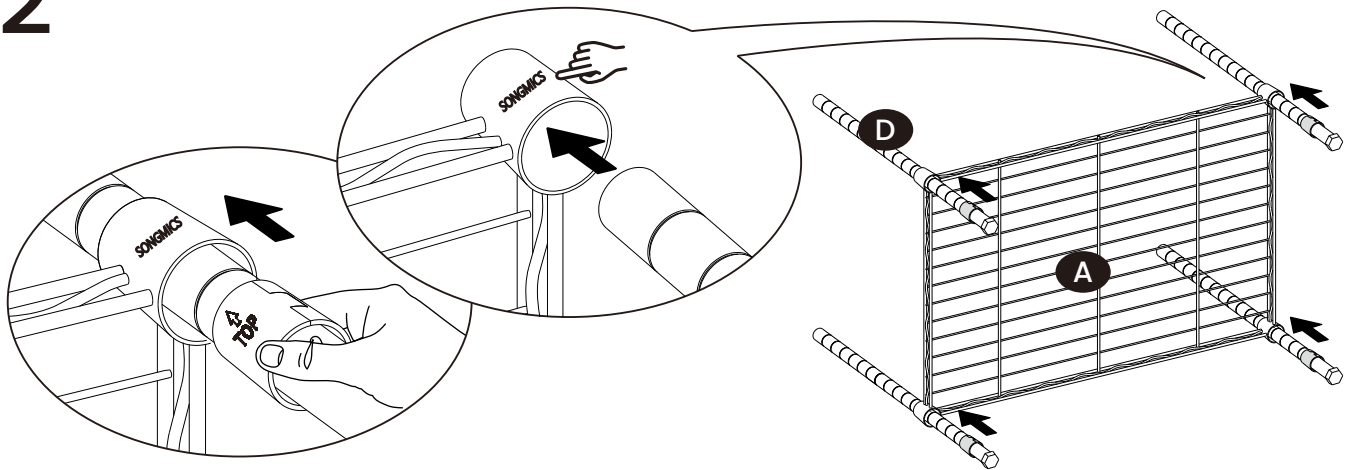

× 2

3

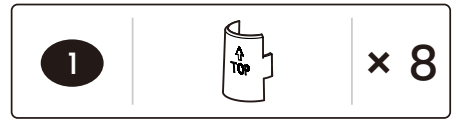
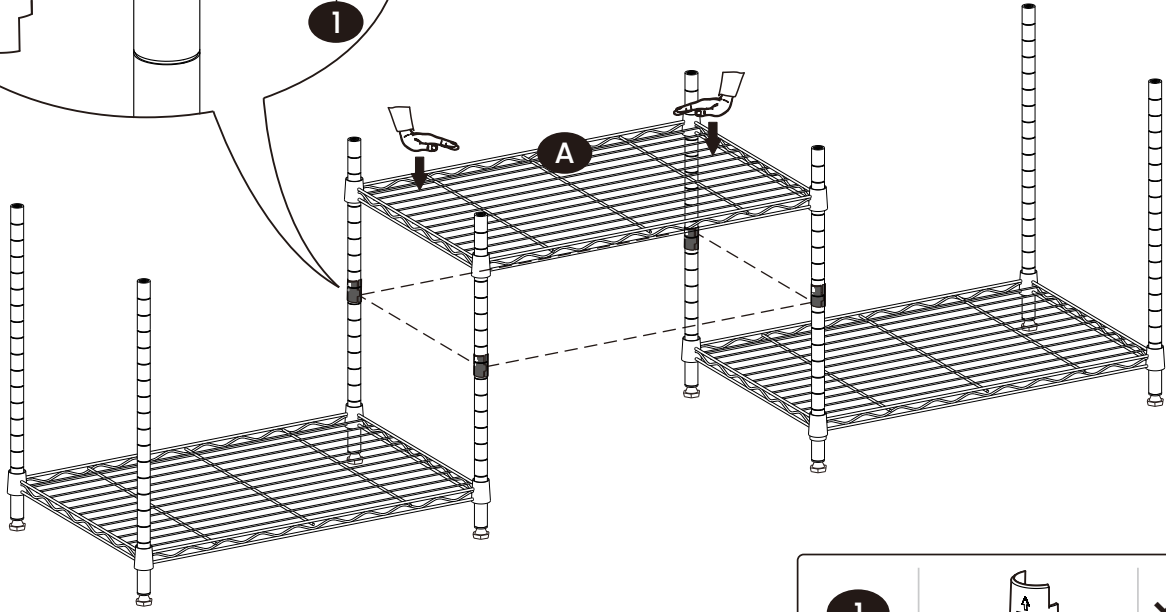
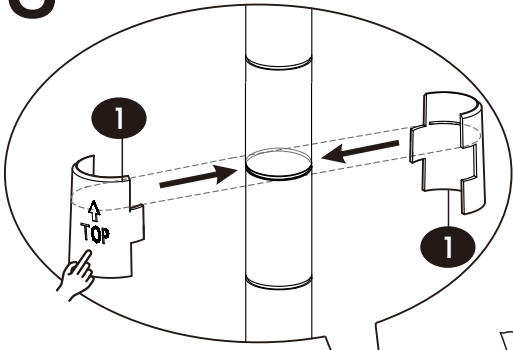

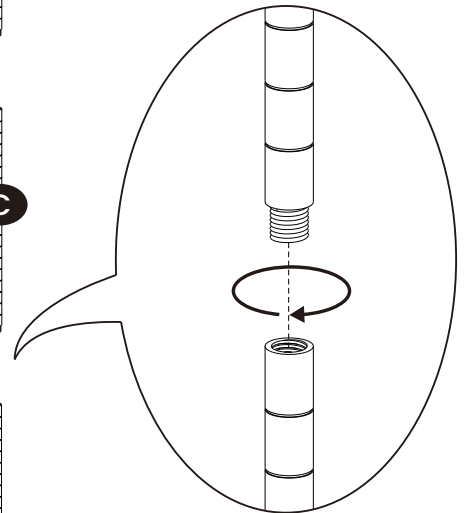
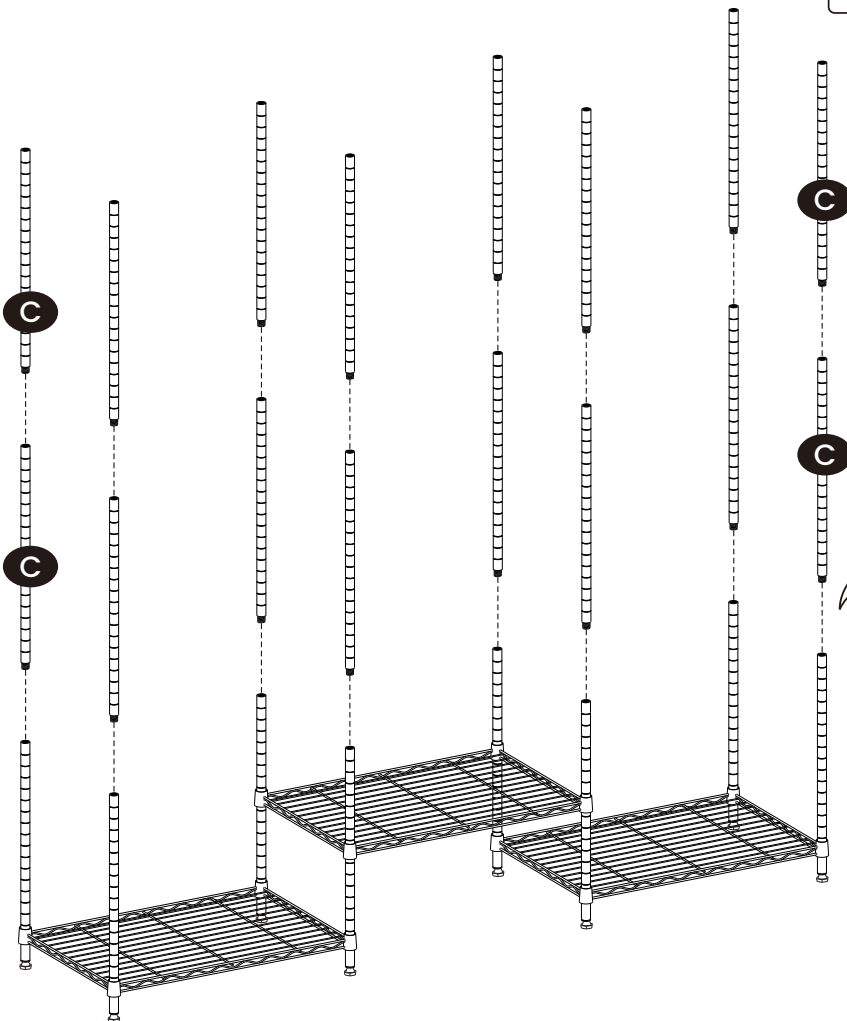

4

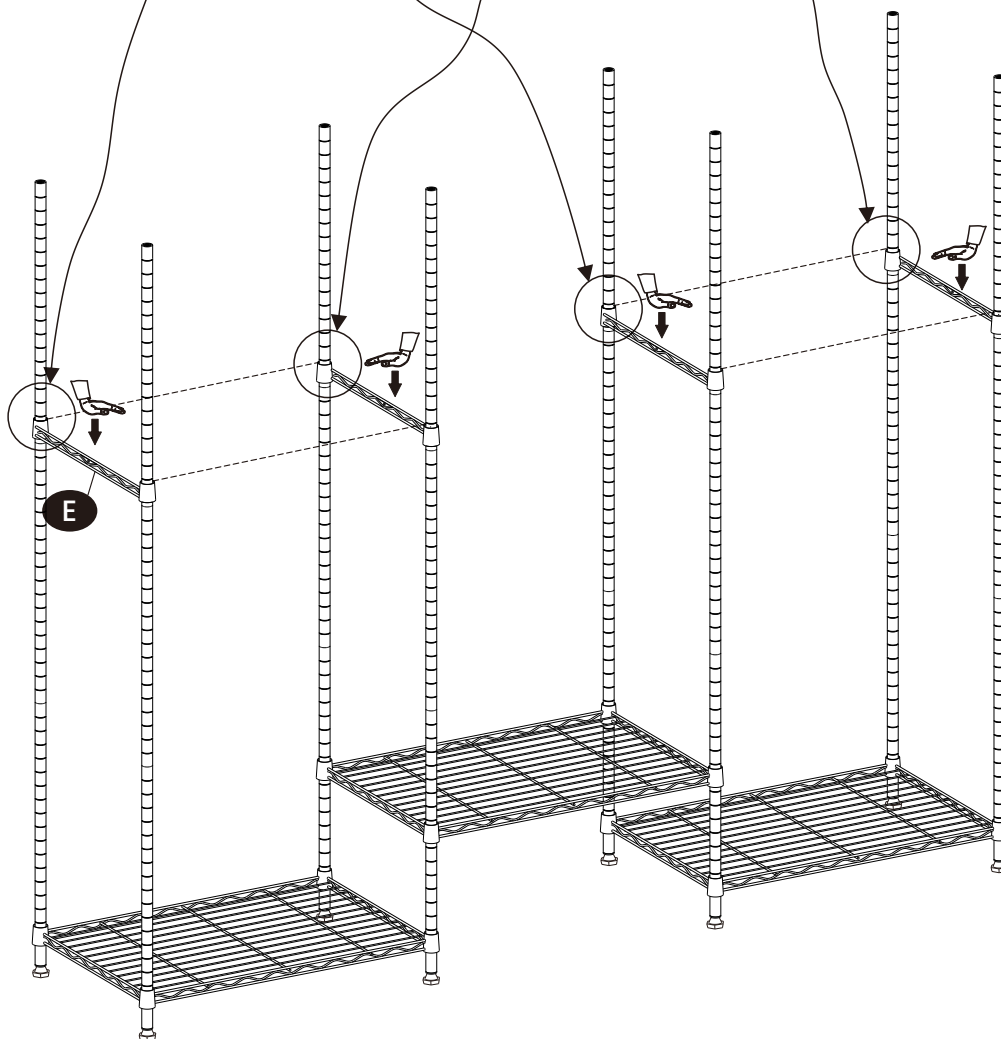
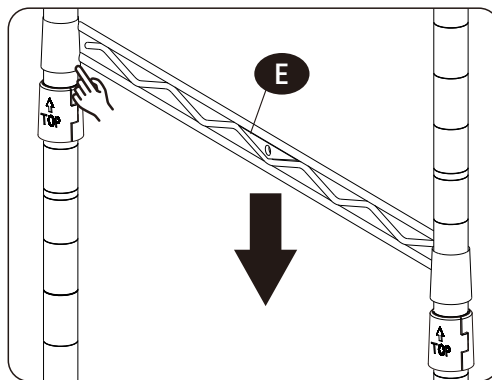
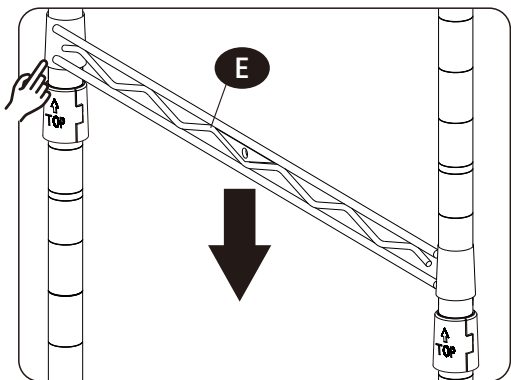
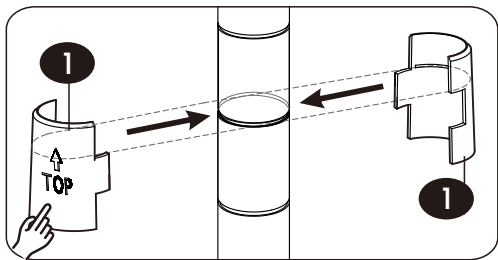

6

5



1		× 16
---	---	------

6

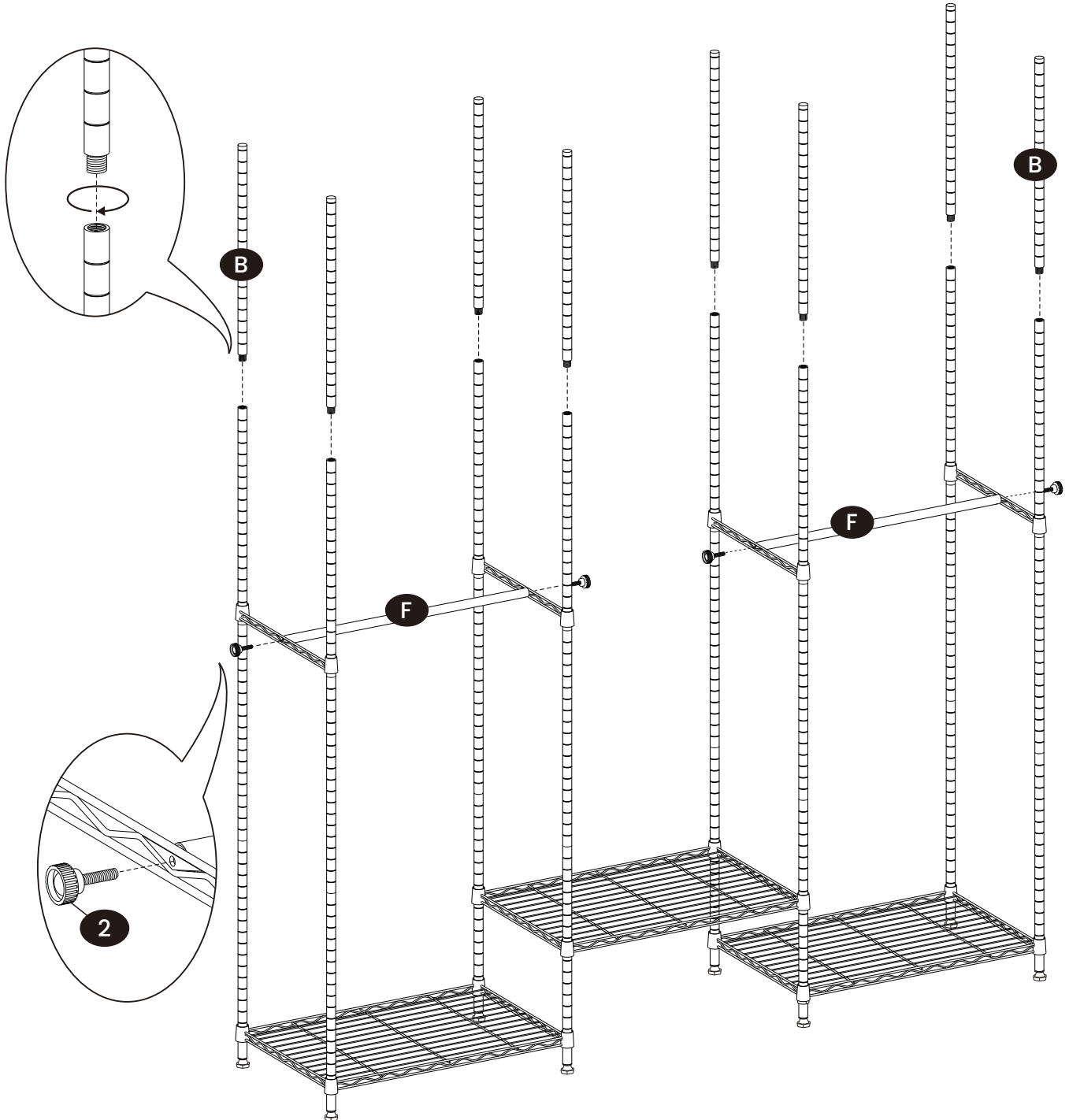

<b>2</b>		<b>× 4</b>
----------	---	------------

7

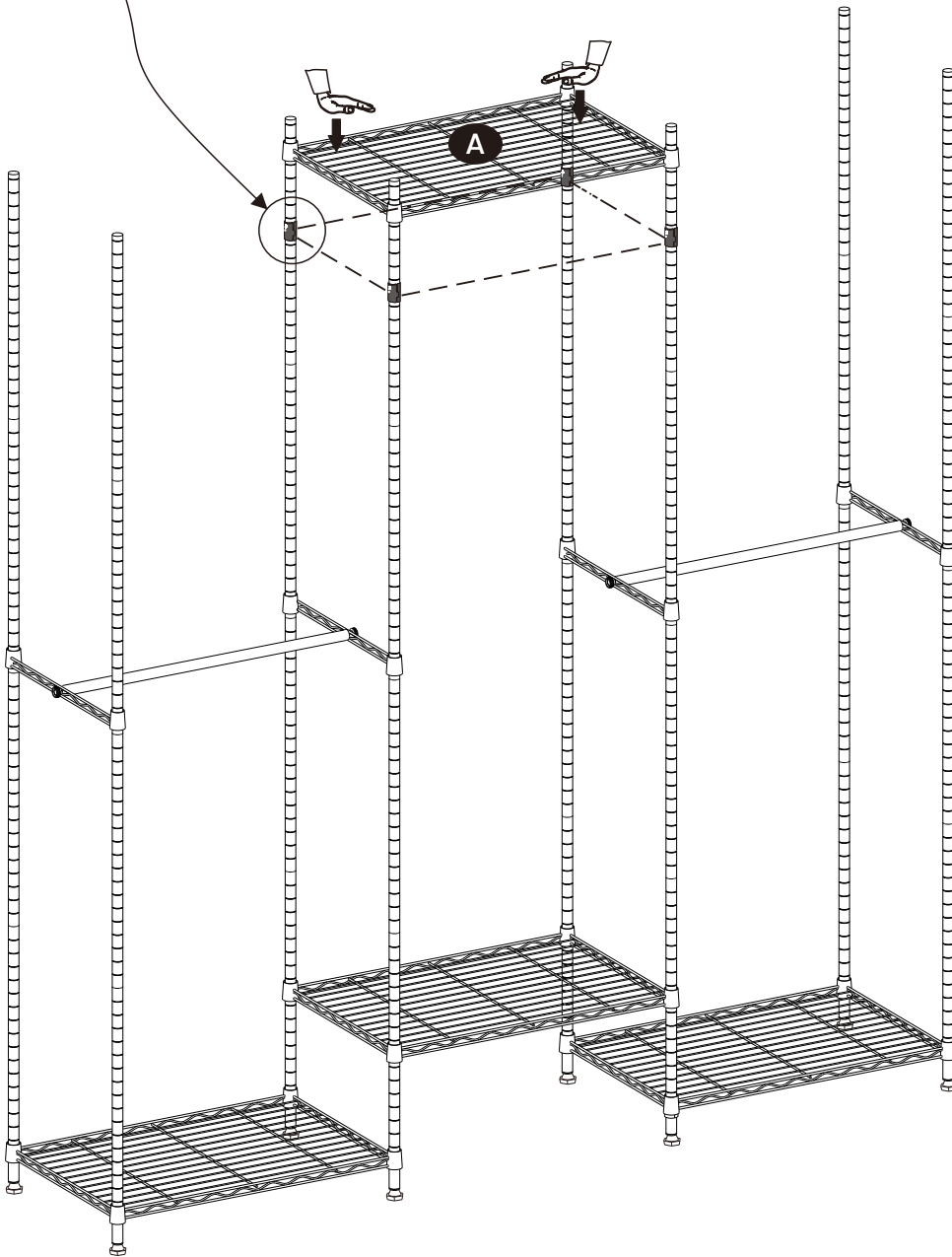
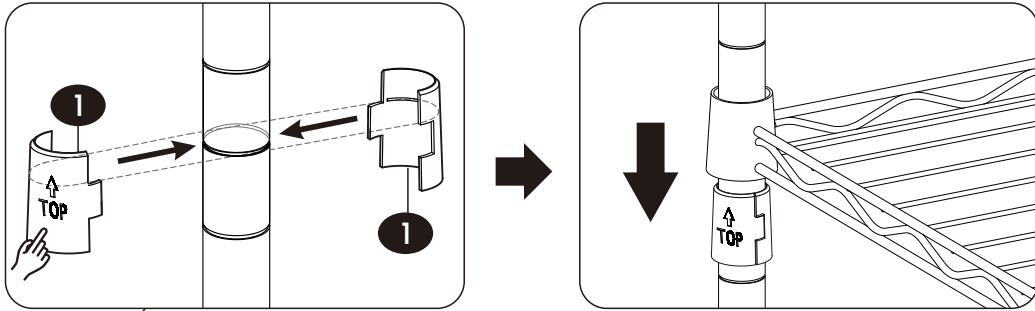

1		x 8
---	---	-----

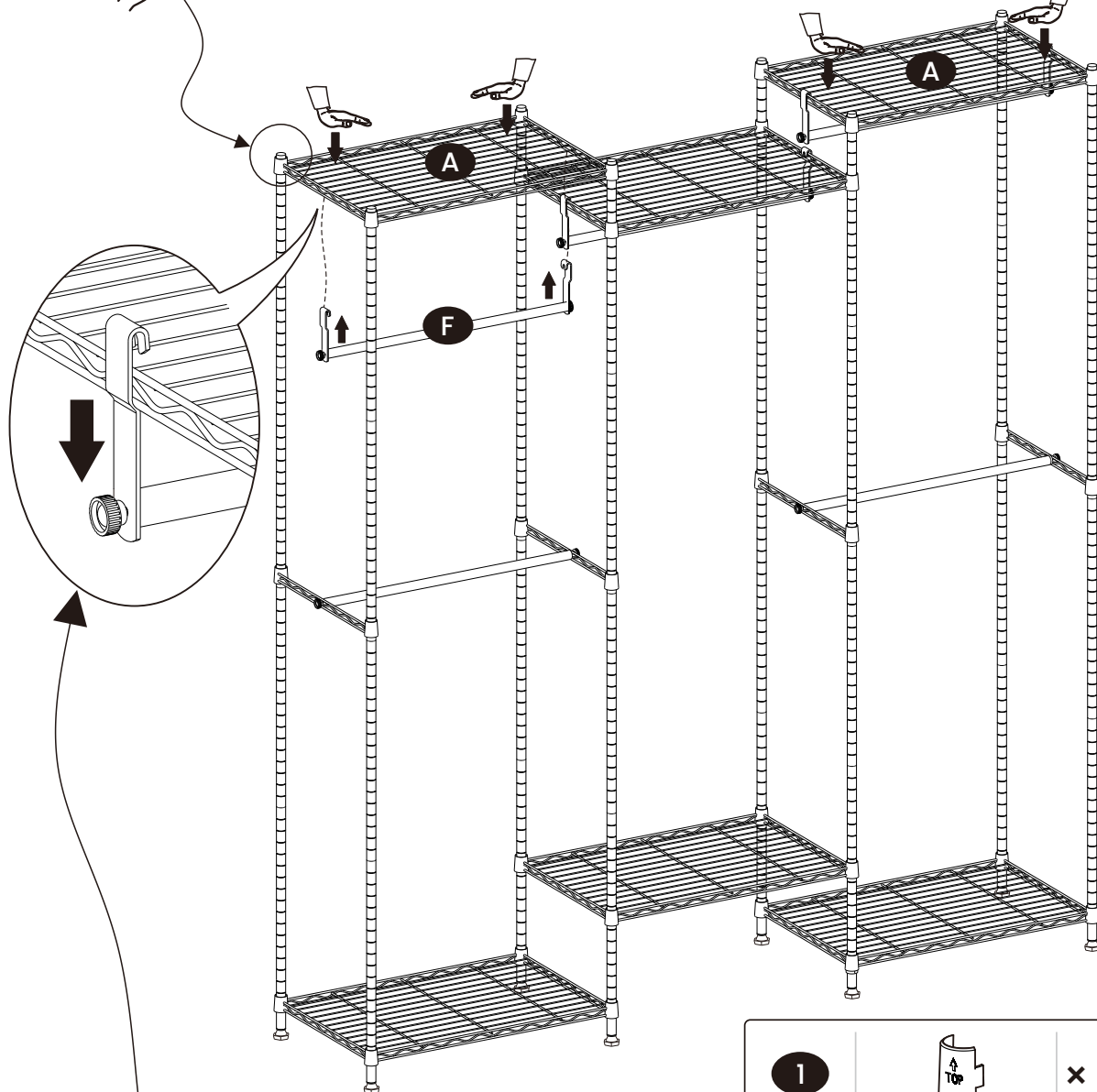
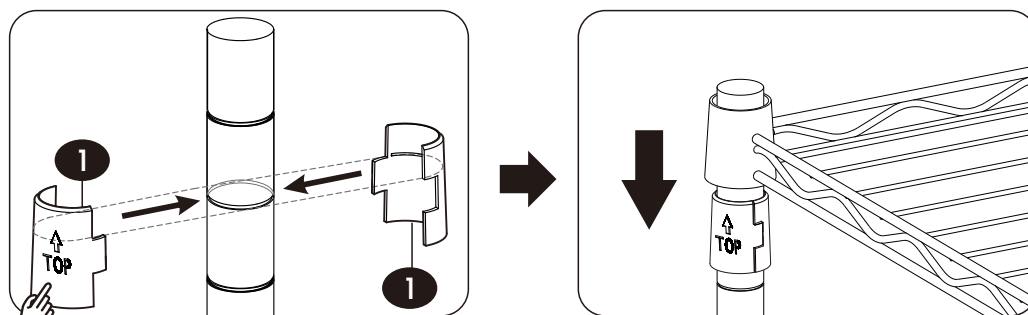

<b>1</b>		<b>× 16</b>
----------	--	-------------

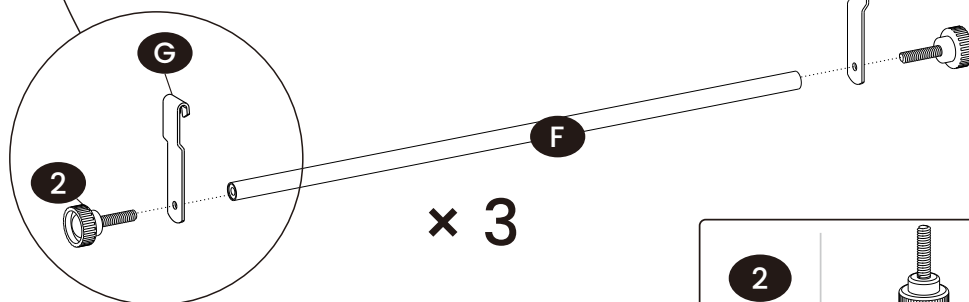

**× 3**

<b>2</b>		<b>× 2</b>
----------	--	------------

# 9

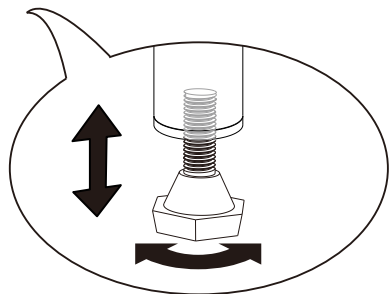
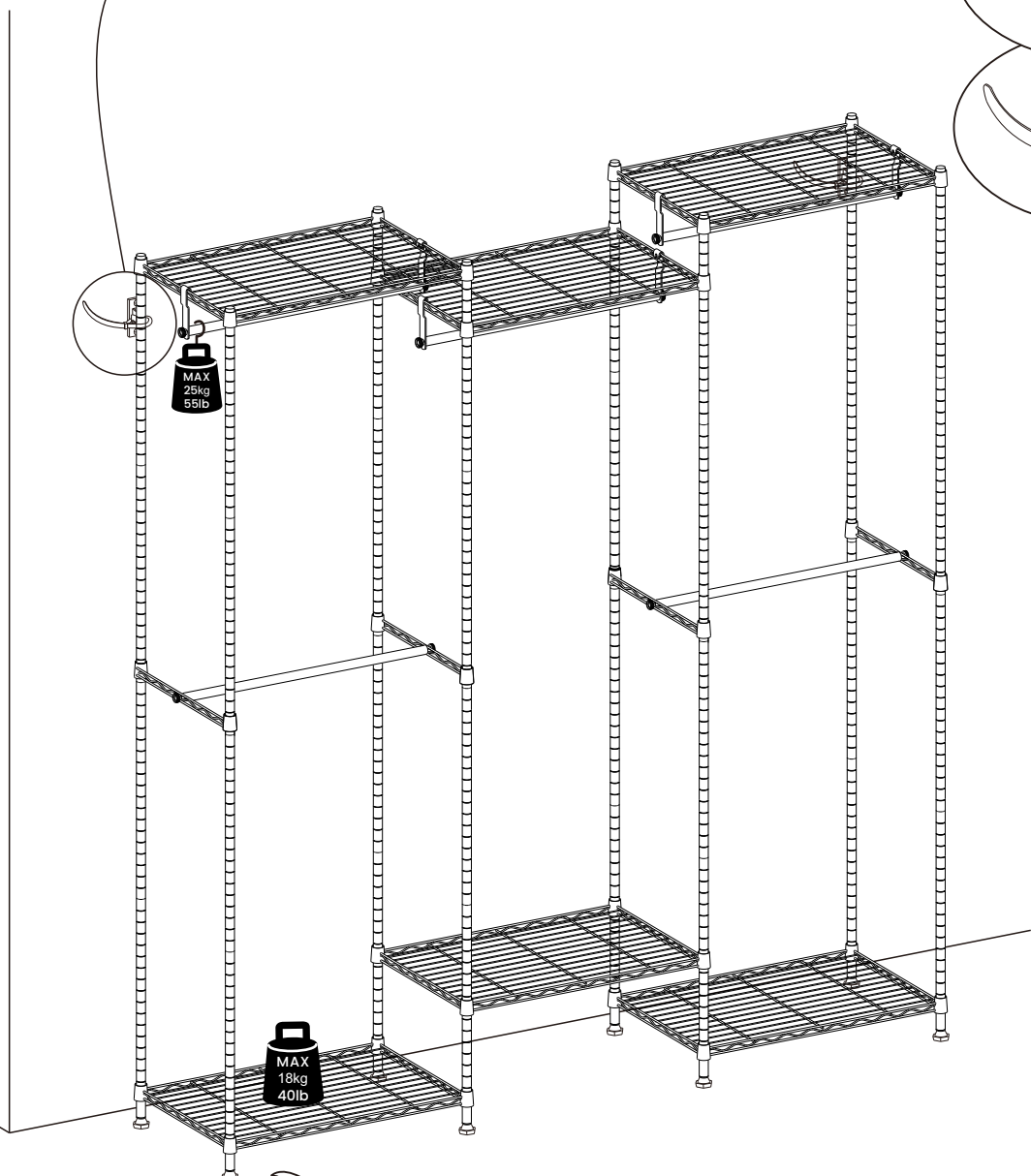
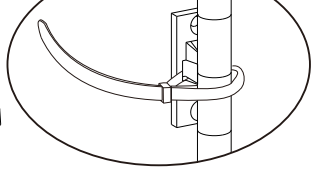
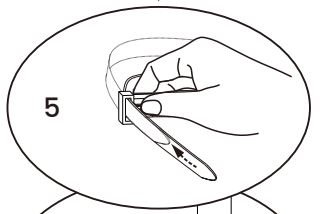
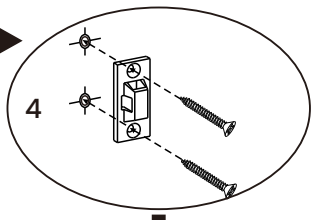
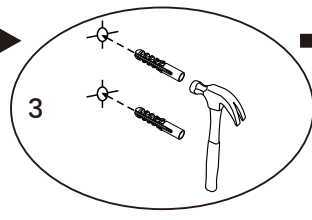
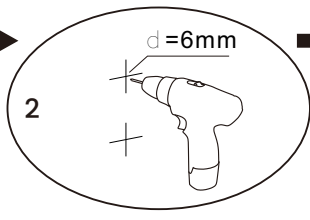
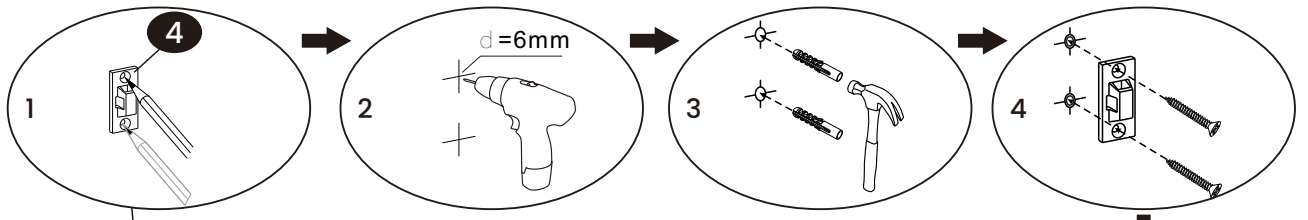

<b>4</b>		<b>× 2</b>
----------	--	------------

**EN**

## Warnings

Please read the following instructions carefully and use the product accordingly.

The instructions may not include every detail of all variations and considered steps. Please contact us for further information and assistance when needed.

Children are not allowed to climb on or drag the product to prevent potential personal injury caused by tipping over.

Place heavier items on the lower shelf to avoid tipping over.

Secure the included anti-tip kit to the wall for safety.

**DE**

## Warnhinweise

Bitte lesen Sie die folgende Anleitung aufmerksam durch und verwenden Sie das Produkt sachgemäß.

Aus Gründen der Übersicht können nicht alle Details zu allen Varianten und denkbaren Montagen beschrieben werden. Wenn Sie weitere Informationen und Hilfe benötigen, kontaktieren Sie uns bitte.

Lassen Sie Kinder nicht auf das Produkt klettern oder an ihm zerren. So werden durch Umkippen verursachte Verletzungen vermieden.

Platzieren Sie schwere Gegenstände bitte auf der unteren Ablage, um ein Umkippen zu vermeiden.

Befestigen Sie dieses Produkt mit dem beiliegenden Kippschutz an der Wand, um eine sichere Nutzung zu gewährleisten.

**FR**

## Avertissements

Lisez attentivement ces instructions et utilisez votre produit d'après ce mode d'emploi.

Pour des raisons de clarté, les détails concernant chaque variante ou montage envisageable ne peuvent être tous décrits. Si vous souhaitez obtenir plus d'informations ou si vous rencontrez certains problèmes non traités de manière détaillée dans ces instructions, veuillez nous contacter.

Il est interdit aux enfants de grimper sur le produit ou de traîner le produit afin d'éviter tout risque de blessures causées par le basculement du produit.

Placez les objets plus lourds sur l'étagère inférieure pour éviter tout risque de basculement.

Pour des raisons de sécurité, il est impératif de fixer le produit au mur avec le dispositif anti-basculement fourni.

**IT**

## Avvertenze

Si prega di leggere attentamente le seguenti istruzioni e utilizzare il prodotto in modo opportuno.

Questo riassunto potrebbe non includere ogni dettaglio di tutte le varianti e le fasi considerate. Si prega di contattarci per ulteriori informazioni e assistenza.

I bambini non sono autorizzati a salire o trascinare il prodotto per evitare potenziali lesioni personali causate dal ribaltamento del prodotto.

Posizionare gli oggetti più pesanti sul ripiano inferiore per evitare il ribaltamento.

Si raccomanda di installare il kit antiribaltamento incluso per sicurezza.

**ES**

## Advertencias

Por favor, lea detenidamente las instrucciones y respete los debidos usos del producto.

Este manual podría no incluir todos los detalles de cada paso del montaje. Si necesita ayuda o información adicional, póngase en contacto con nosotros.

No se permite que los niños se suban o arrastren el producto para evitar posibles lesiones personales causadas por el vuelco del producto.

Coloque los artículos más pesados en el estante inferior para evitar que se vuelquen.

Se recomienda instalar el dispositivo de fijación incluido por seguridad.

**NL**

## Waarschuwingen

Gelieve de handleiding na te lezen en het product zo te gebruiken.

Deze samenvatting bevat mogelijk niet alle variaties en stappen. Gelieve contact op te nemen indien u meer informatie of hulp nodig hebt.

Kinderen zijn niet toegestaan om op het product te klikken of het te versleuren om persoonlijk letsel te voorkomen.

Plaats zwaardere voorwerpen op de onderste plank om te voorkomen dat ze omvallen.

Het wordt aanbevolen om het bijgeleverde anti-kantel hulpstuk voor de veiligheid te installeren.

**SE**

## Varningar

Var god läs följande instruktioner noggrant och använd produkten därefter.

Instruktionerna kan inte omfatta varje detalj av alla varianter och övervägda steg. Kontakta oss för ytterligare information och hjälp vid behov.

Barn får inte klättra på eller dra produkten för att förhindra potentiella personsador orsakade av att den välter.

Placera tyngre föremål på den nedre hyllan för att undvika att den välter.

Fäst det medföljande tipskyddet på väggen för säkerhet.

**PL**

## Ostrzeżenia

Proszę uważnie przeczytać niniejsze instrukcje oraz odpowiednio używać produkt.

Instrukcje mogą nie zawierać wszystkich szczegółów dotyczących wszystkich wariantów i rozważanych kroków. W razie potrzeby prosimy o kontakt z nami w celu uzyskania dalszych informacji i pomocy.

Dzieciom nie wolno wspinać się na produkt ani go przeciągać, aby zapobiec potencjalnym obrażeniom spowodowanym przewróceniem się.

Umieść cięższe przedmioty na niższej półce, tak aby uniknąć przewrócenia.

Dla bezpieczeństwa przymocuj do ściany dołączony zestaw zabezpieczający przed przewróceniem.

**TR**

## Uyarılar

Lütfen aşağıdaki talimatları dikkatlice okuyun ve ürünü belirtildiği şekilde kullanın.

Talimatlar, tüm varyasyonların ve dikkate alınan adımların her detayını içermeyebilir. Daha fazla bilgi ve yardım gerektiğinde lütfen bizimle iletişime geçin.

Çocukların devrilme sonucu potansiyel kişisel yaralanmaları önlemek için ürüne tırmanmasına veya ürünü sürüklemesine izin verilmez.

Rafın devrilmesini önlemek için ağır eşyaları alt rafa yerleştirin.

Güvenlik için dahil edilen devrilme önleyici kiti duvara sabitleyin.

**JP**

## 安全警告メッセージ

安全にご使用頂くため、「組立説明書」をよくお読みの上、正しくご使用下さい。

お組立中、何か不明がございましたら、弊社までお気軽にお問い合わせください。

本品に乗ったり、座ったりしないでください。ケガや破損のおそれがあります。

転倒を防ぐために、重いものは下の棚に置いてください。

安全のため、転倒防止用の安全紐を壁面に固定することをお勧めします。

販売元: ZIEL JP株式会社 〒531-0062 大阪市北区長柄中3丁目6番13号

TEL: 06-7161-1020 メール: info\_jp@songmics.jp