

LSC204-S

Storage Cabinet

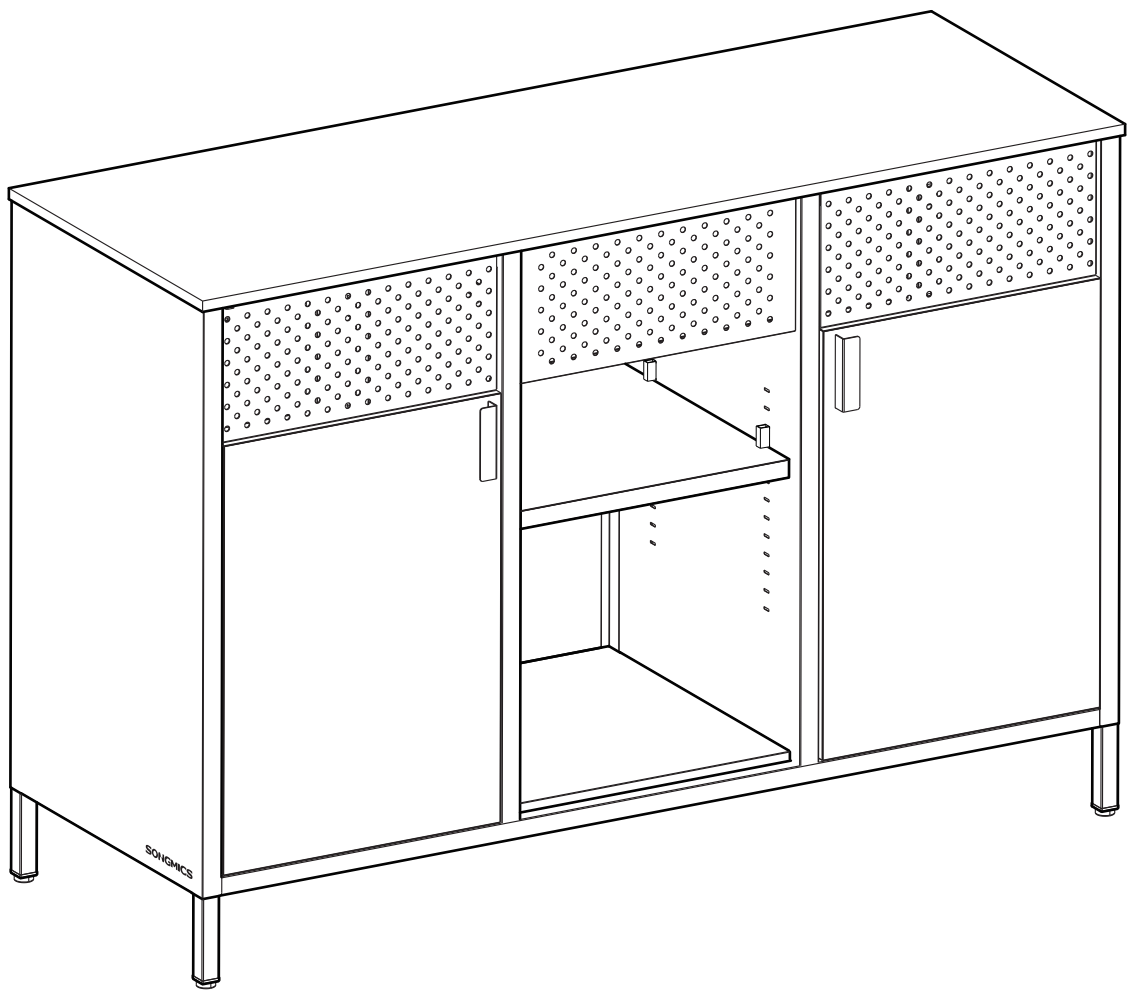

SONGMICS
by SONGMICS HOME

A × 2

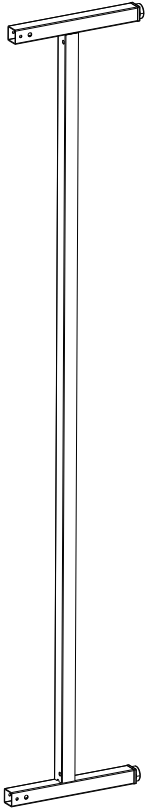

B × 1

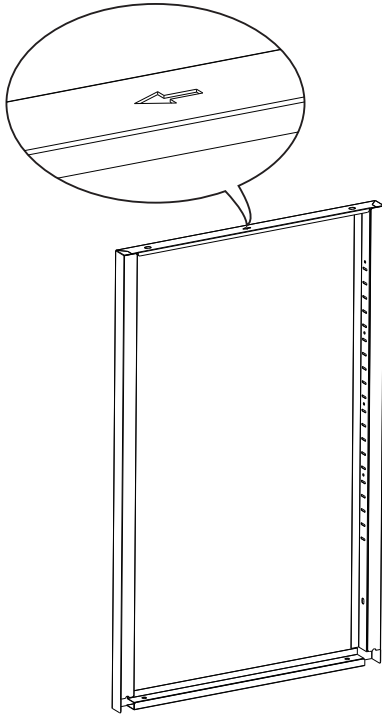

C × 1

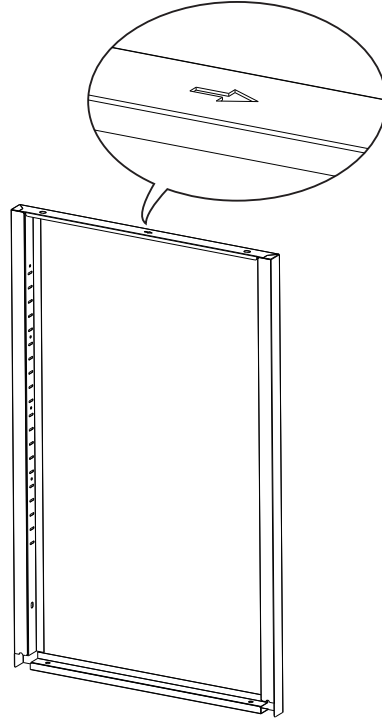

D × 1

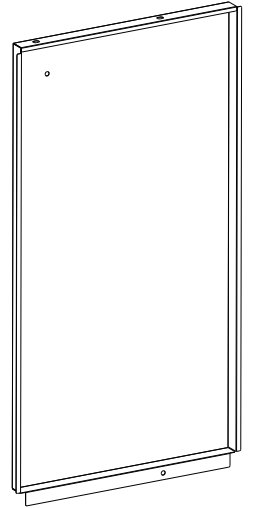

E × 1

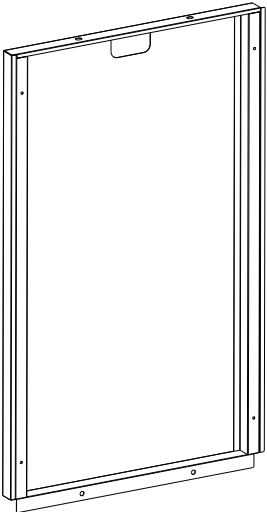

F × 1

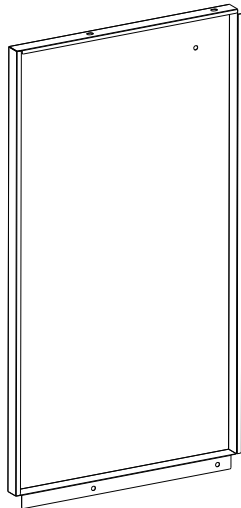

G × 1

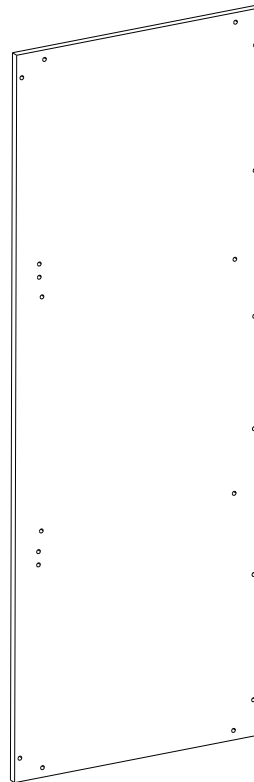

H × 1

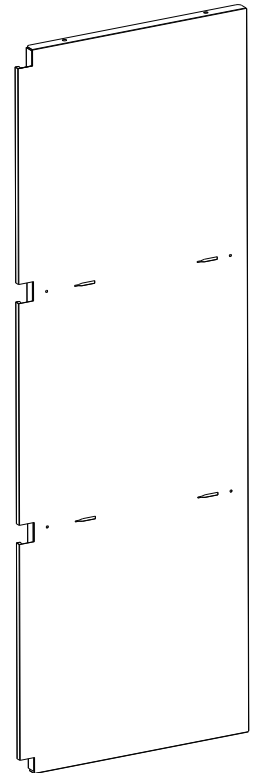

I × 1

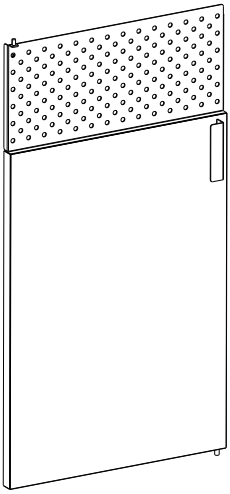

J × 1

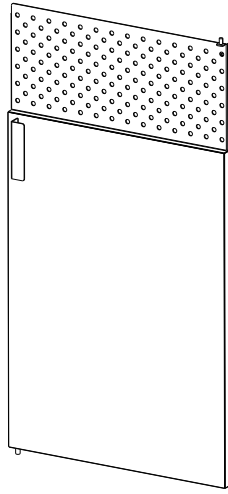

K × 1

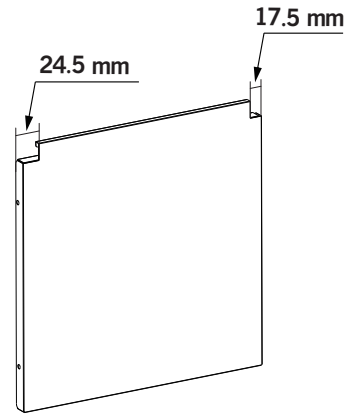

L × 1

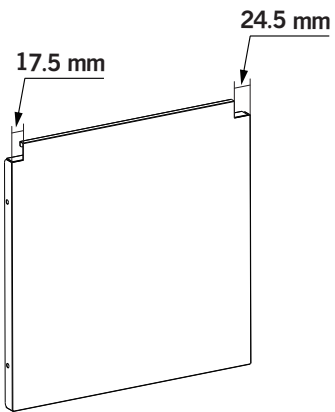

M × 1

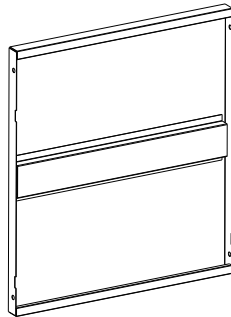

N × 1

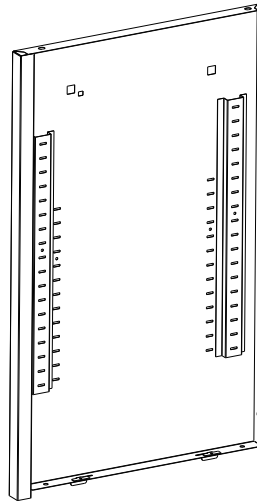

O × 1

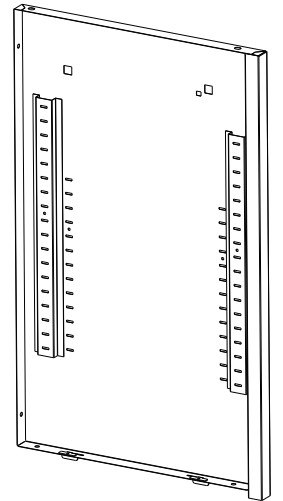

P × 1

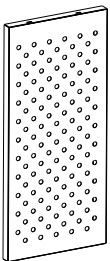

Q × 1

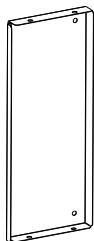

R × 1



S × 1

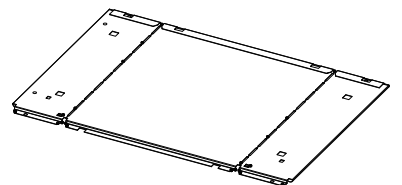

1 x 2

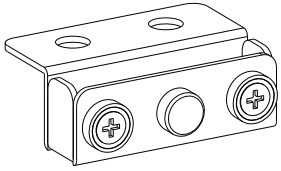

2 12+2



3 18+2



4 2+2



5 x 4

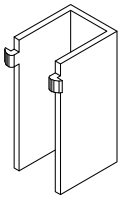

6 12+2

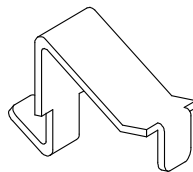

7 x 2

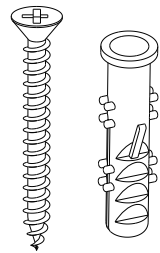

8 x 1

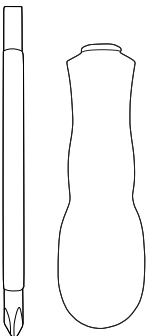

9 x 1



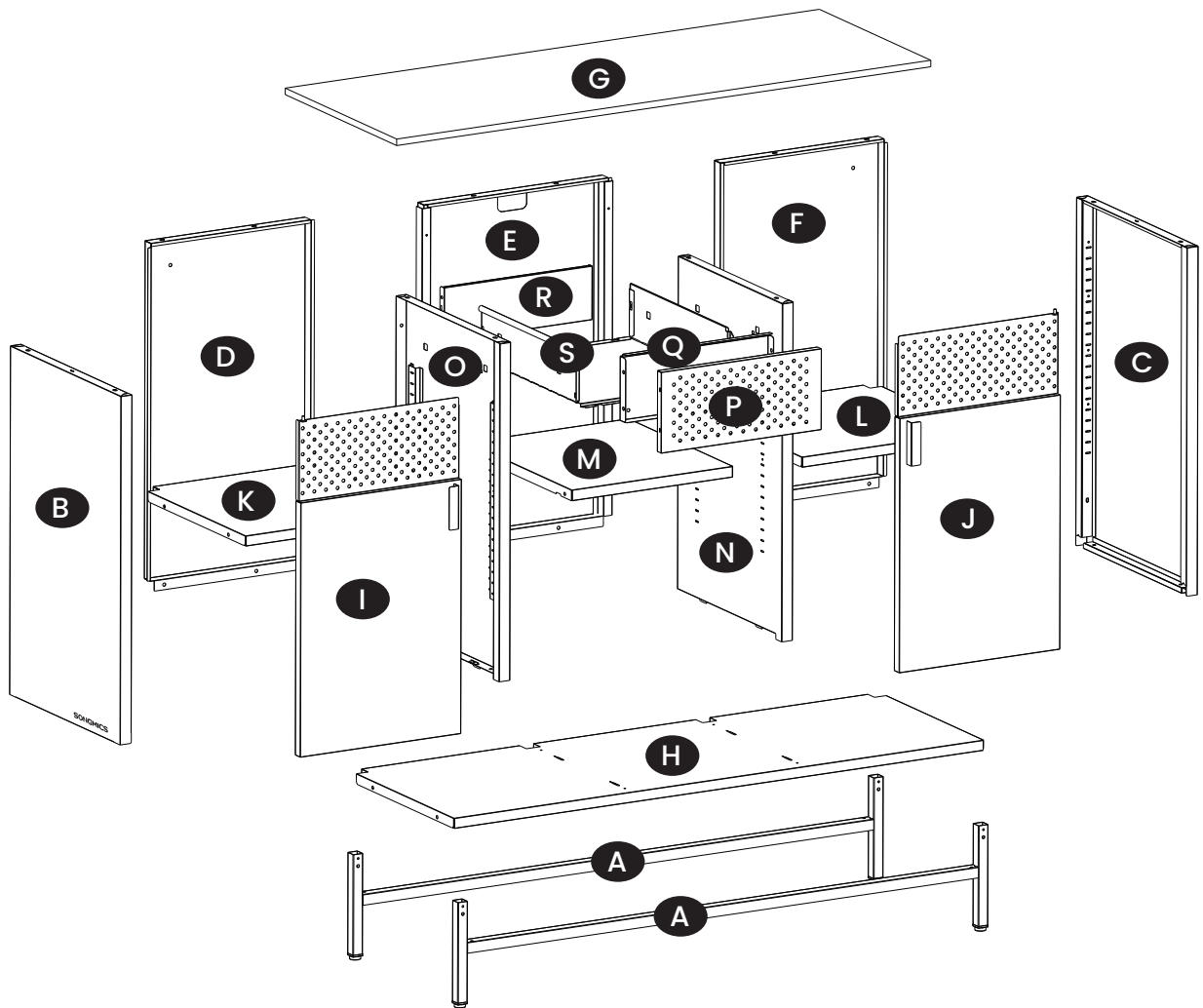

Tools Required:

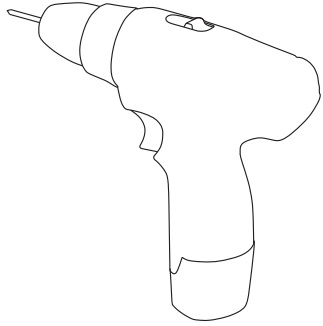

1

- EN Note: The side with the hole should be on the outermost side of the tube.
- DE Hinweis: Die Öffnungen an den Querstangen sollten sich an der äußeren Seite befinden.
- FR Note : Le côté avec le trou doit se trouver vers l'extérieur.
- IT Note: Il lato con il foro dovrebbe essere sul lato pi, esterno del tubo.
- ES Nota: El lado con el agujero debe estar en el lado más exterior del tubo.

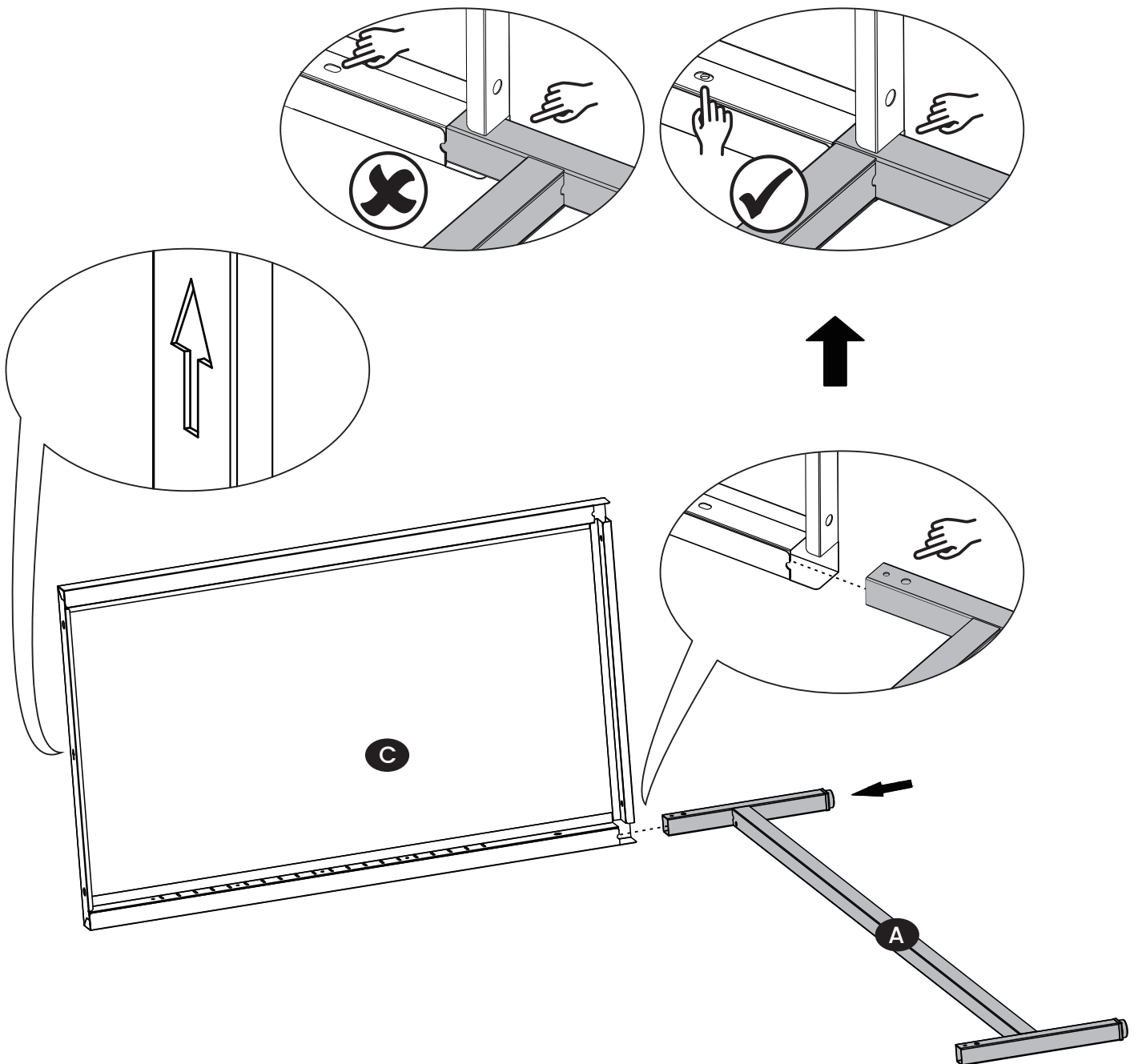

2

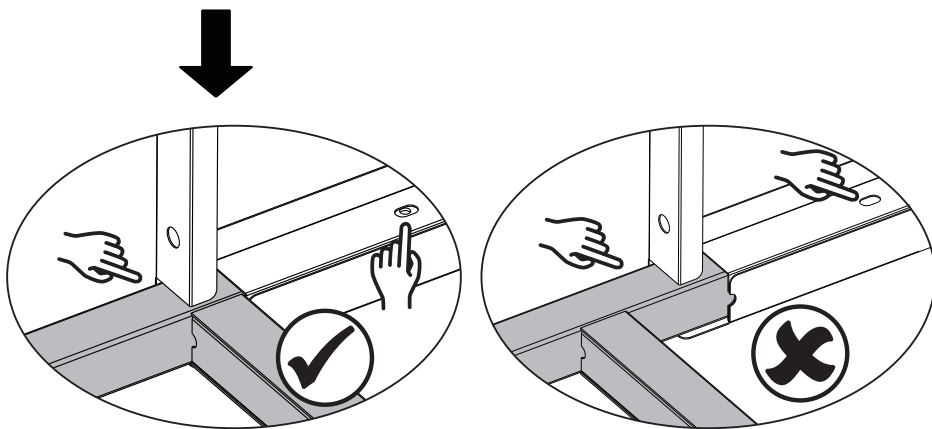
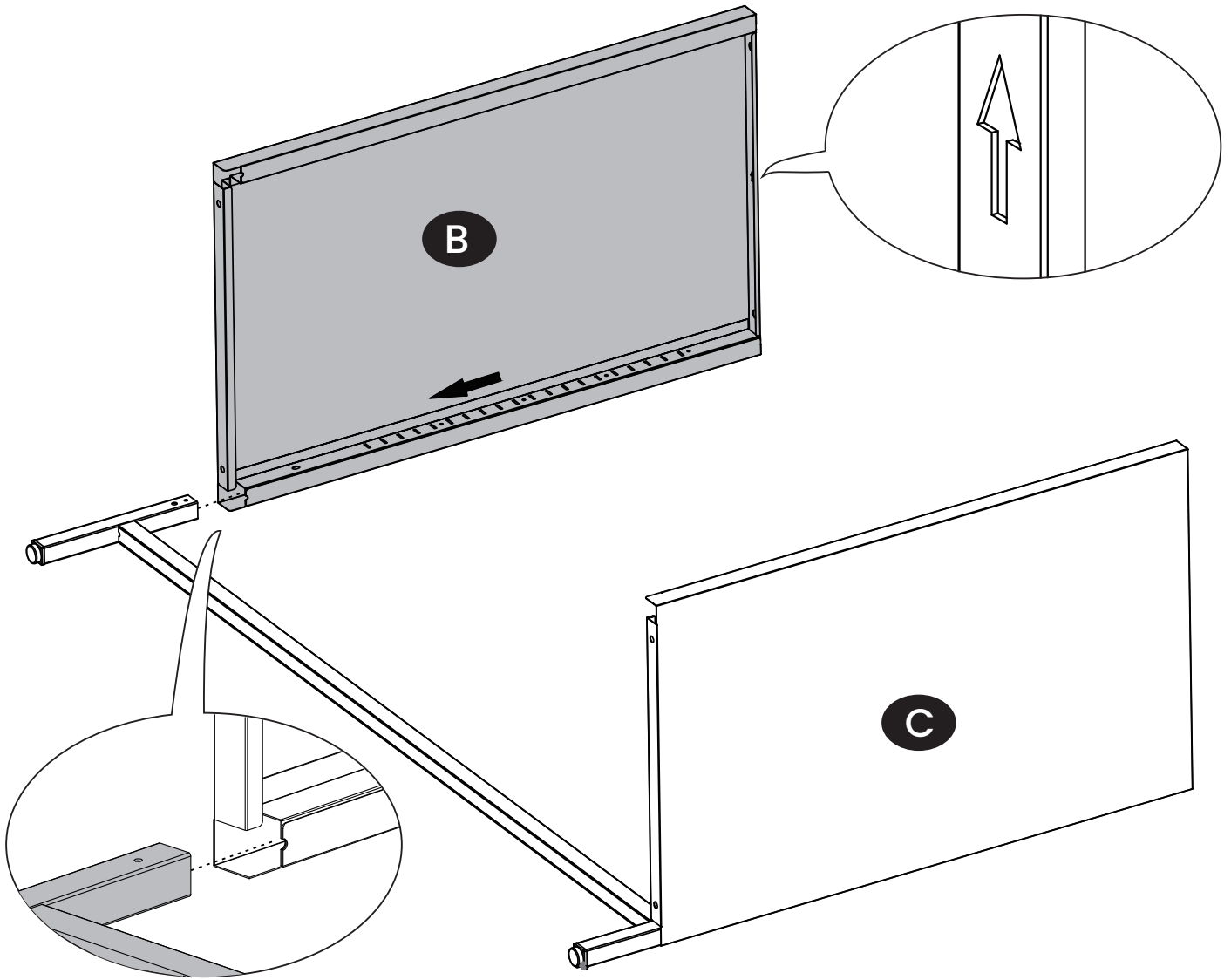

3

- EN Note: The side with the hole should be on the outermost side of the tube.
- DE Hinweis: Die Öffnungen an den Querstangen sollten sich an der äußeren Seite befinden.
- FR Note : Le côté avec le trou doit se trouver vers l'extérieur.
- IT Note: Il lato con il foro dovrebbe essere sul lato più esterno del tubo.
- ES Nota: El lado con el agujero debe estar en el lado más exterior del tubo

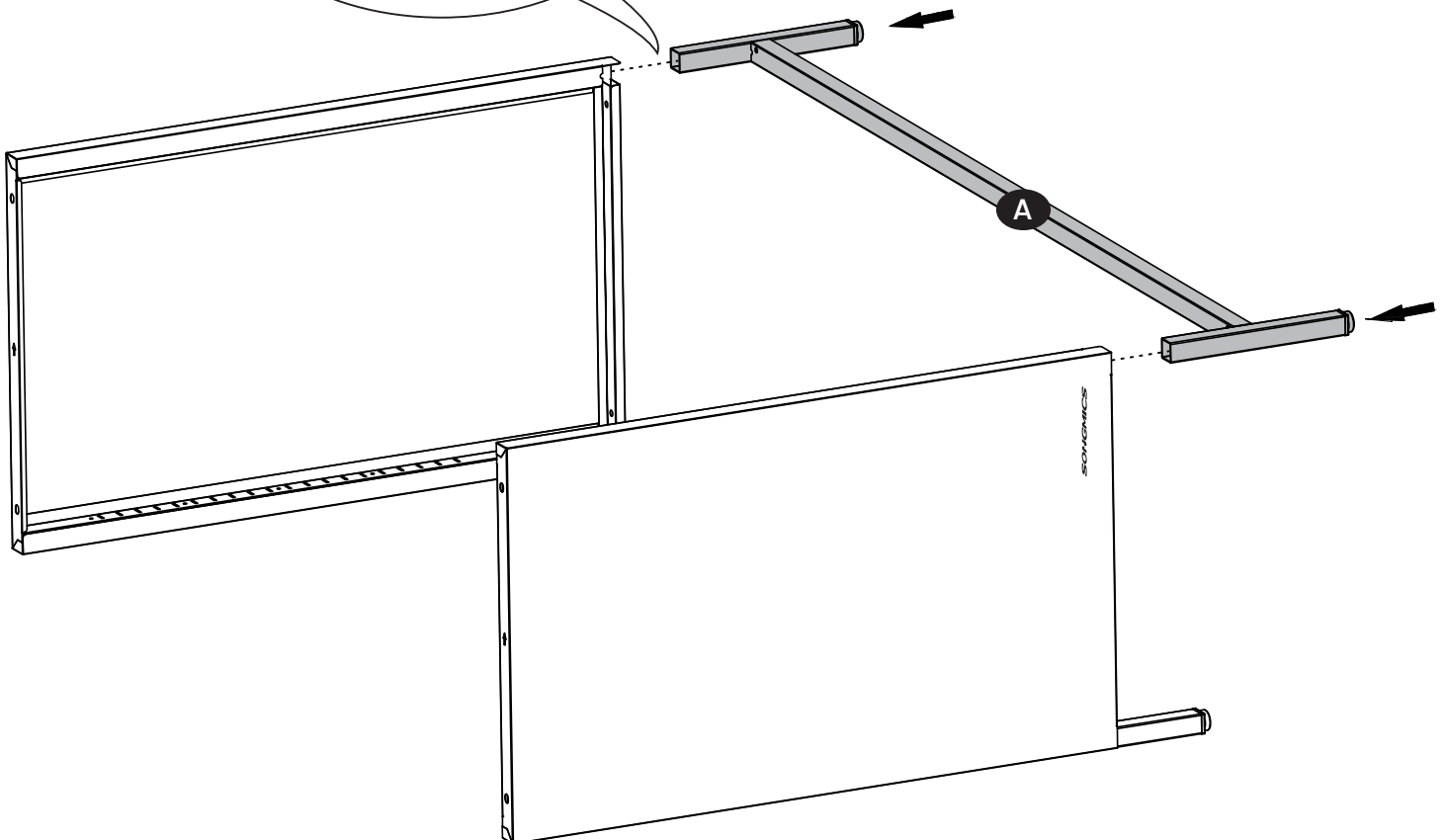
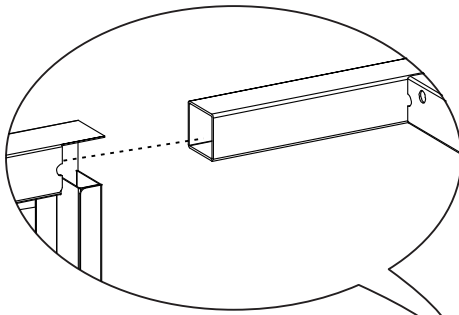
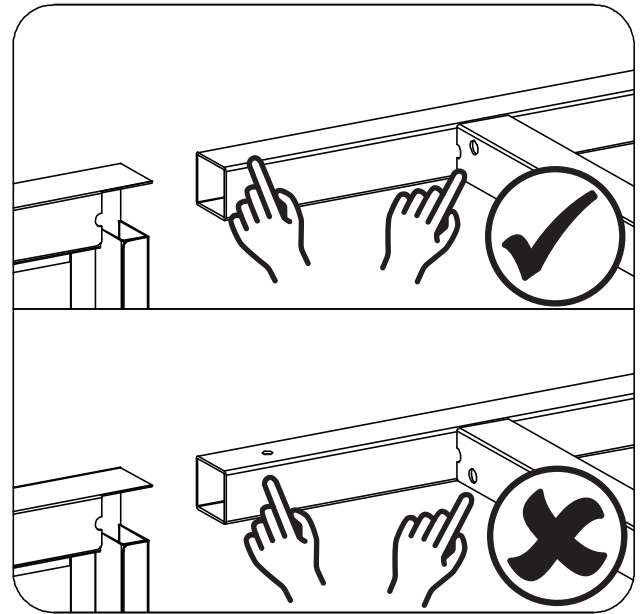

4

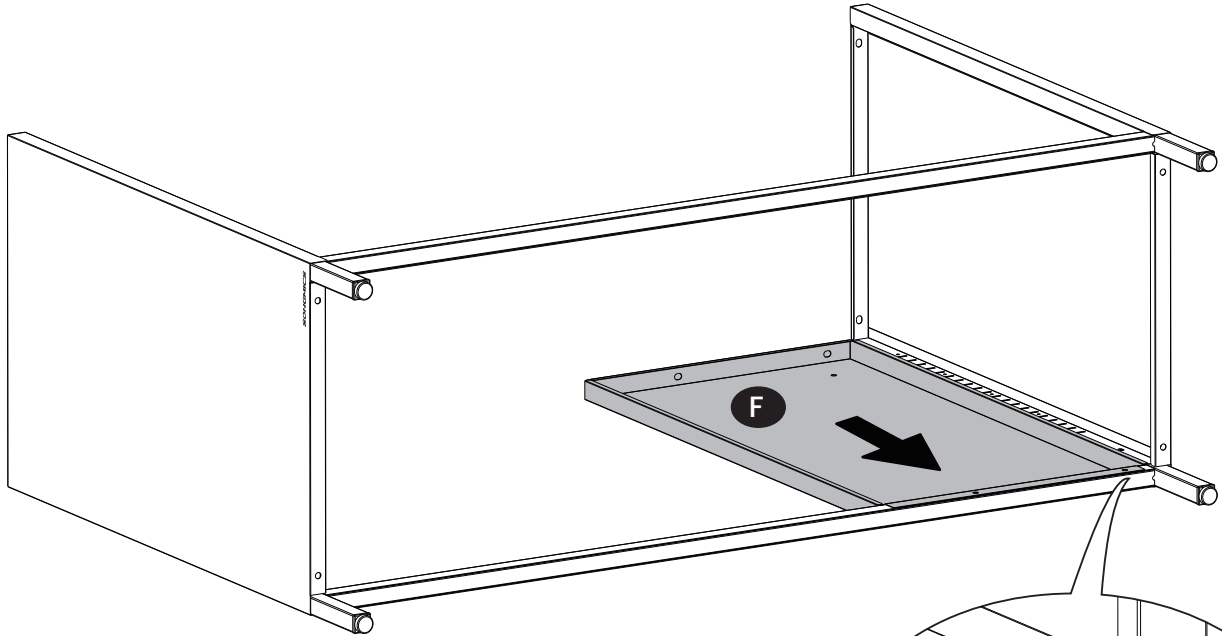
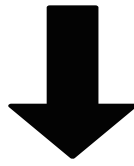
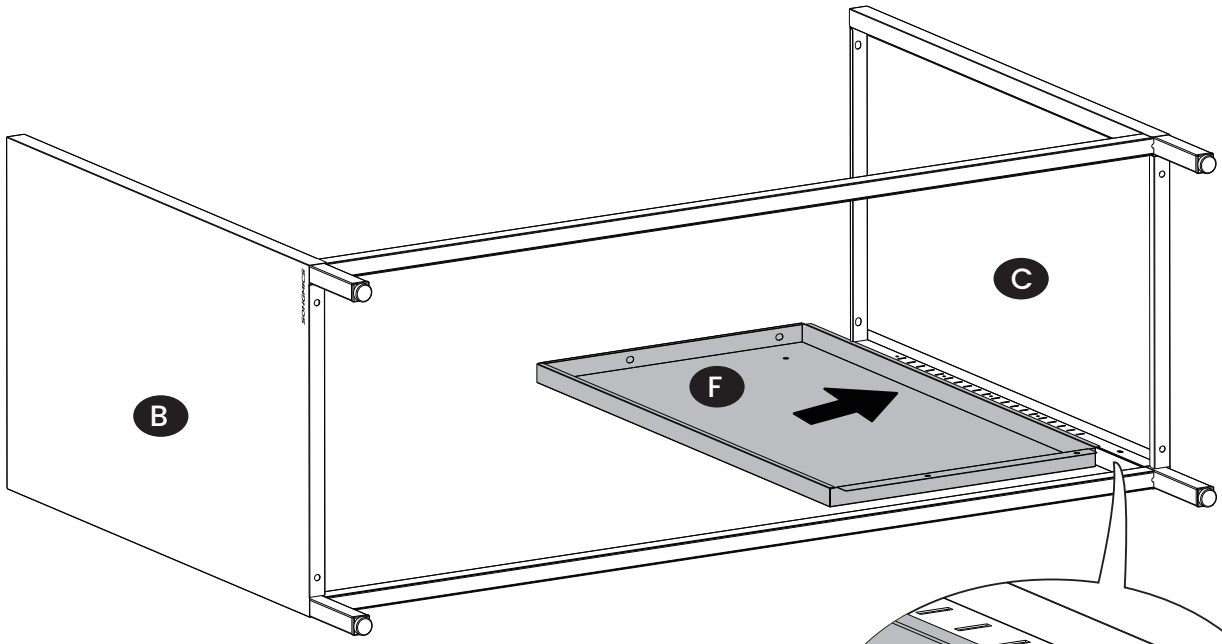

5

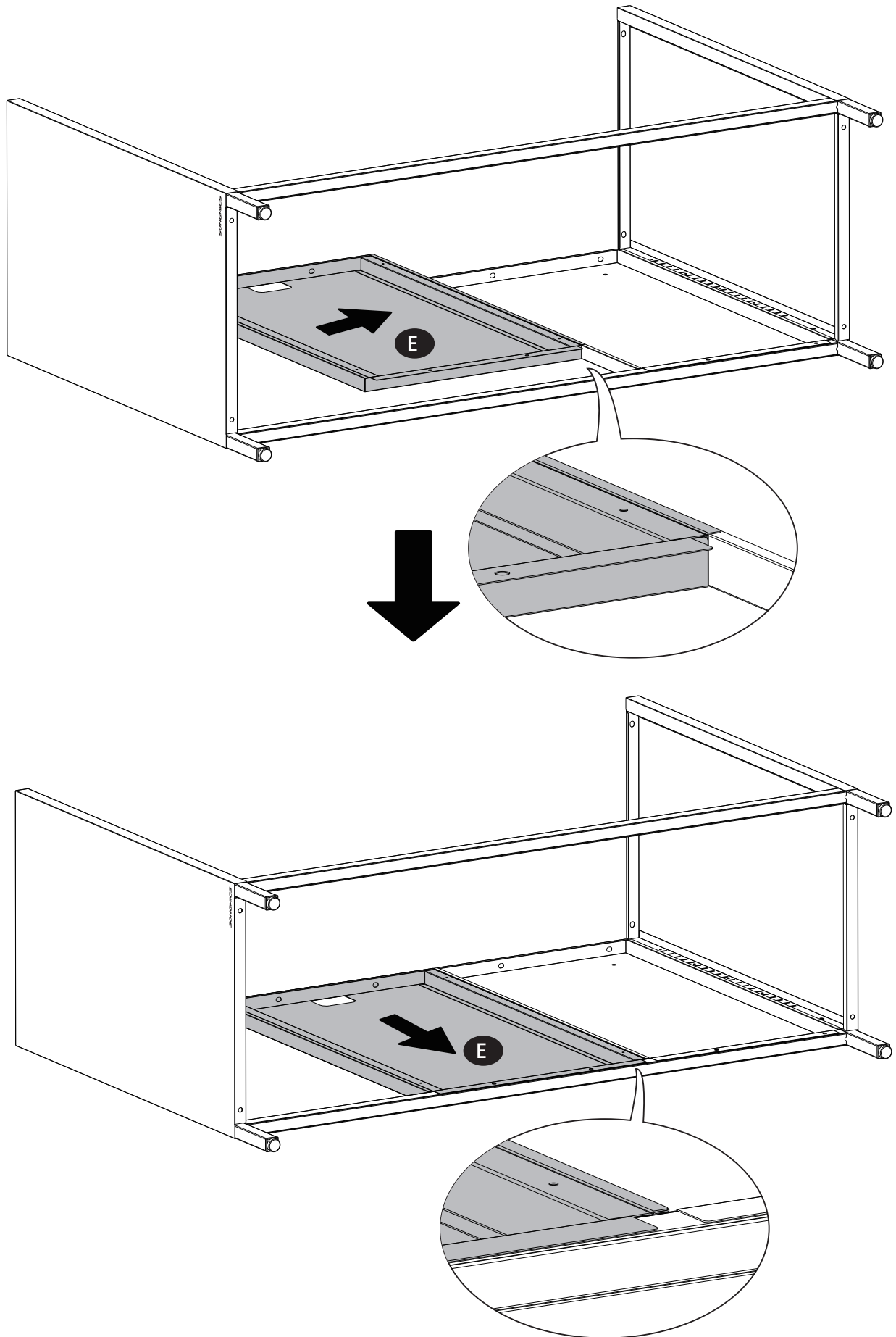

6

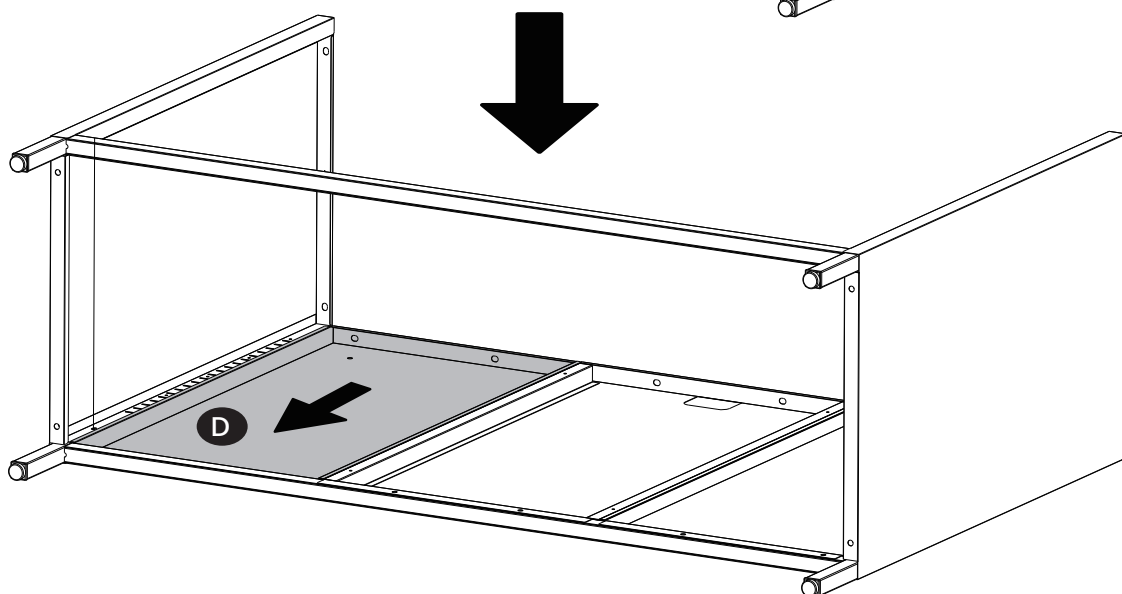
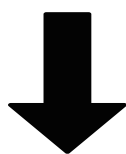
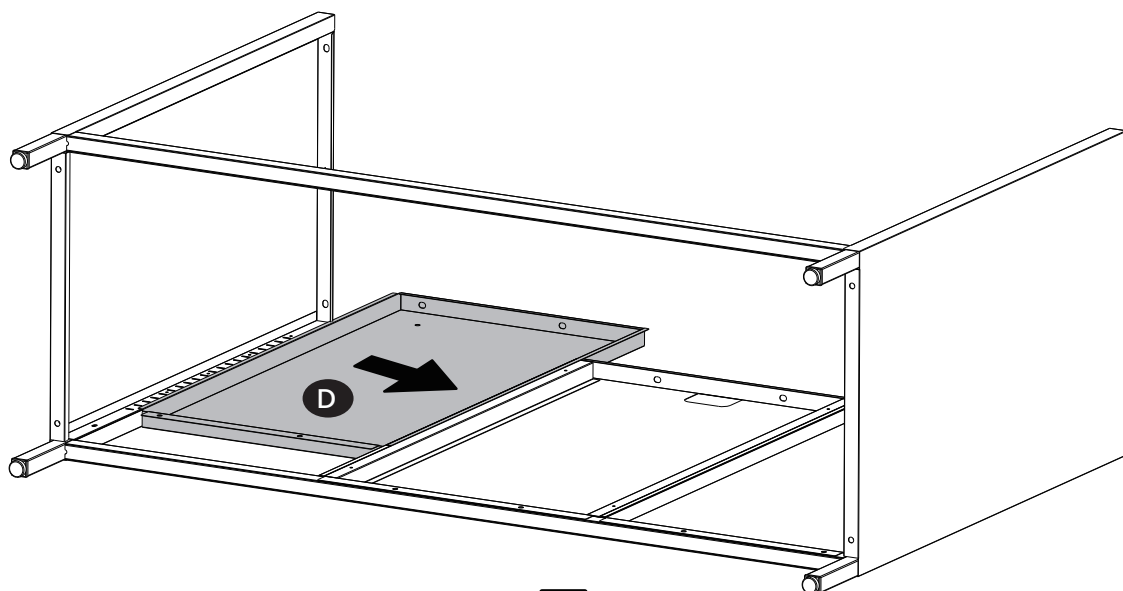

7

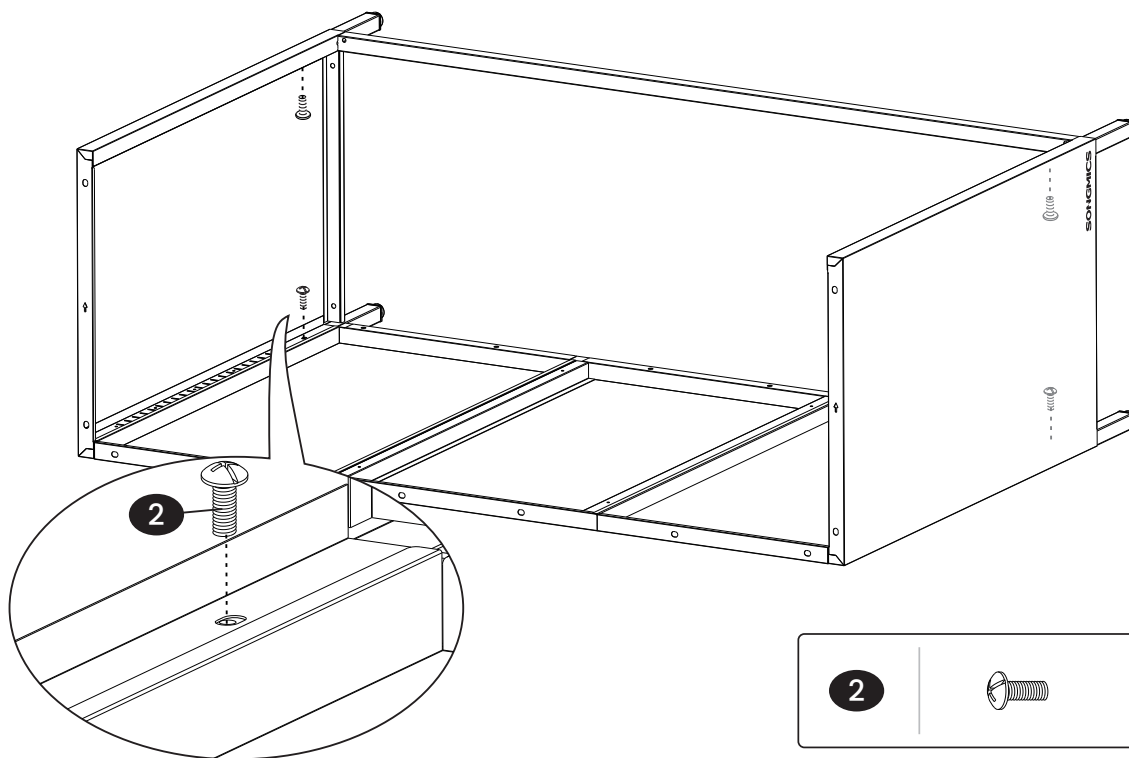

8

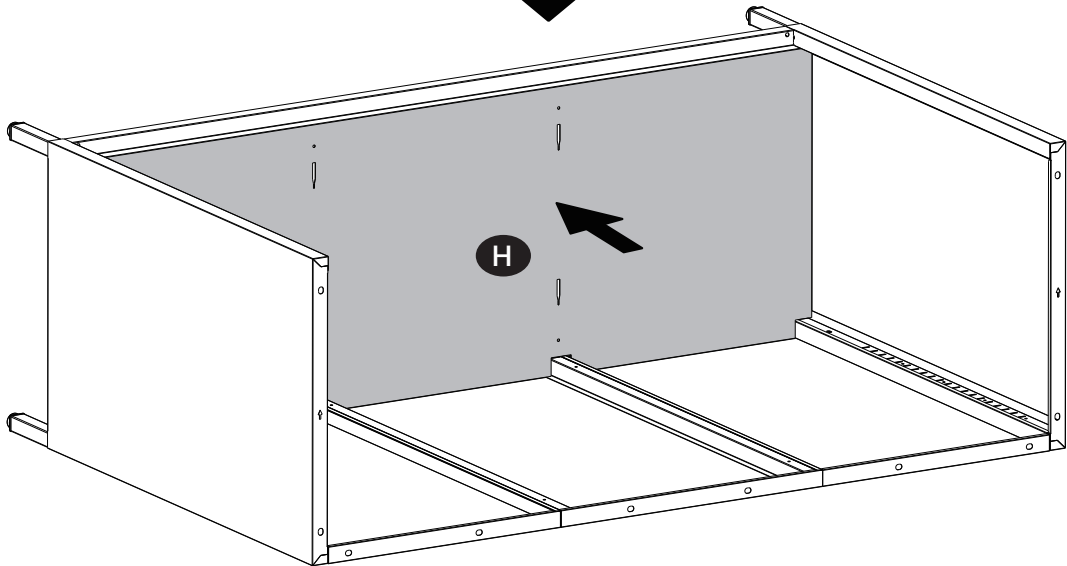
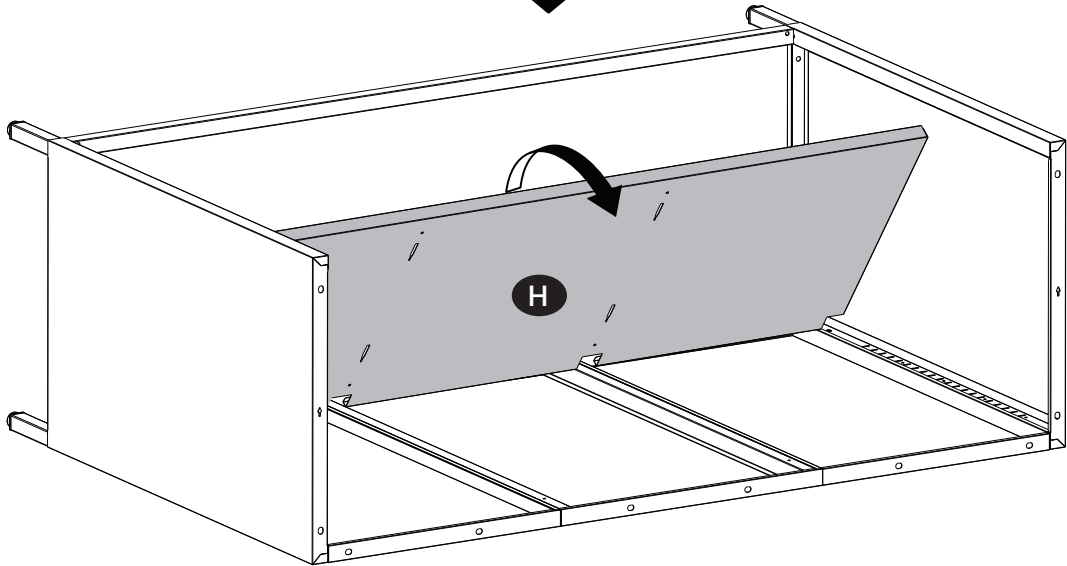
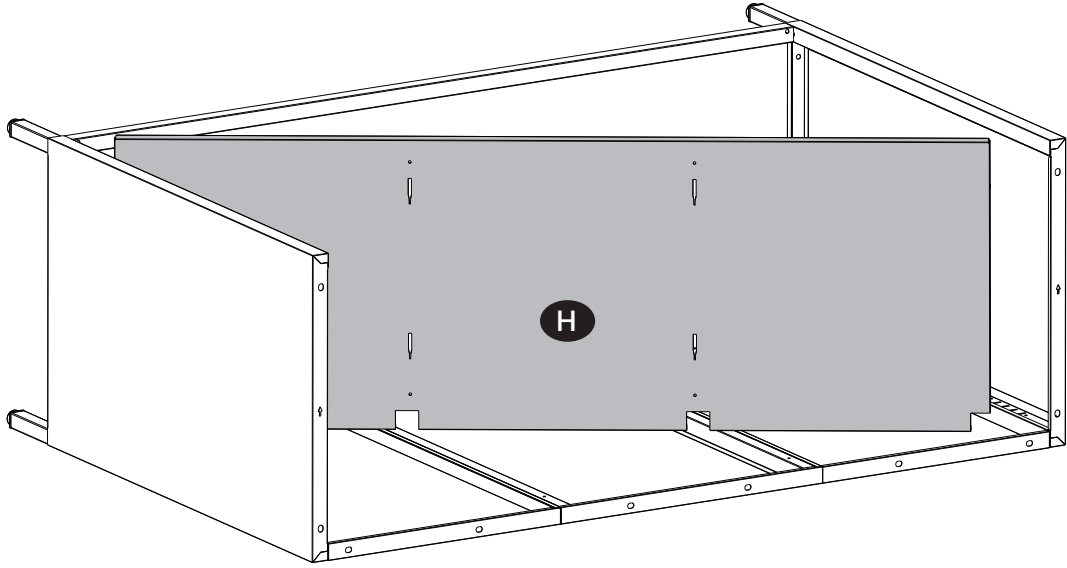

9

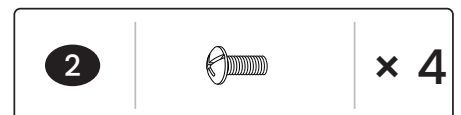
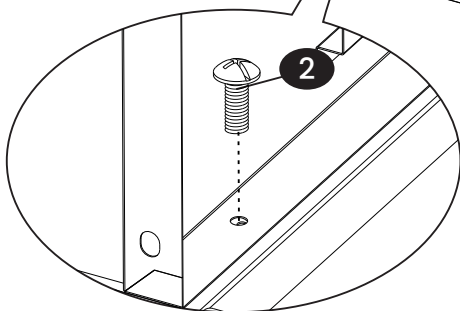
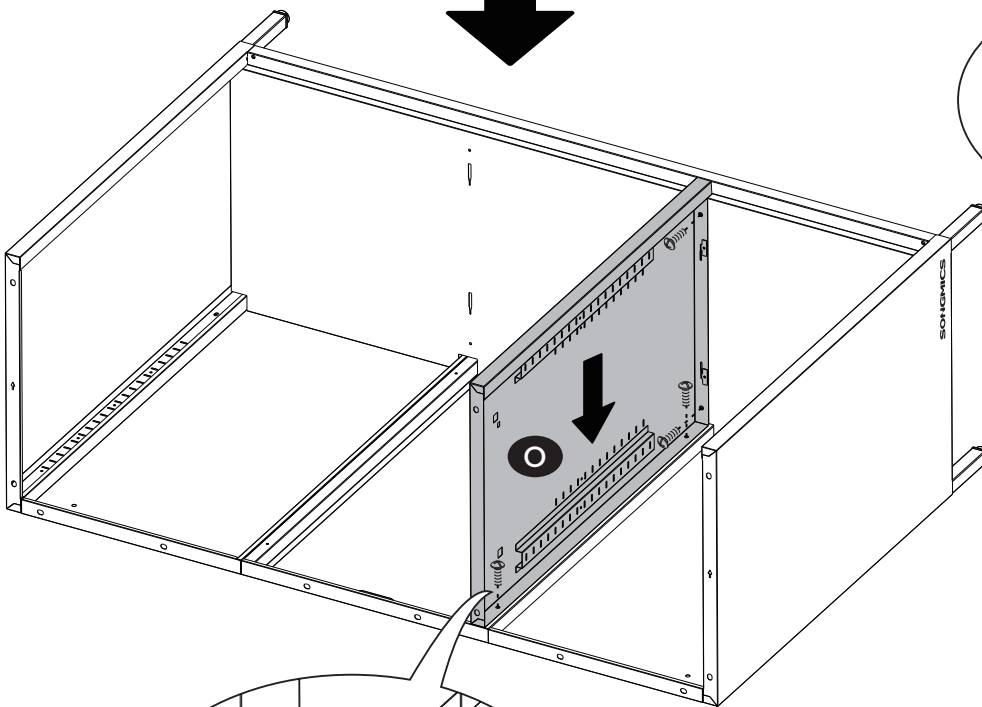
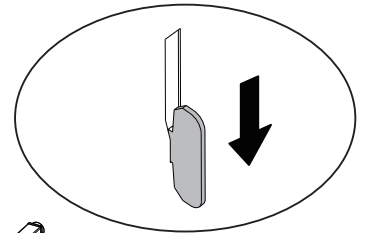
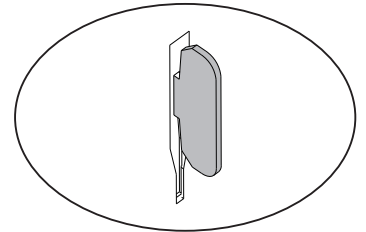
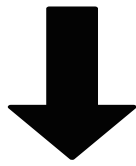
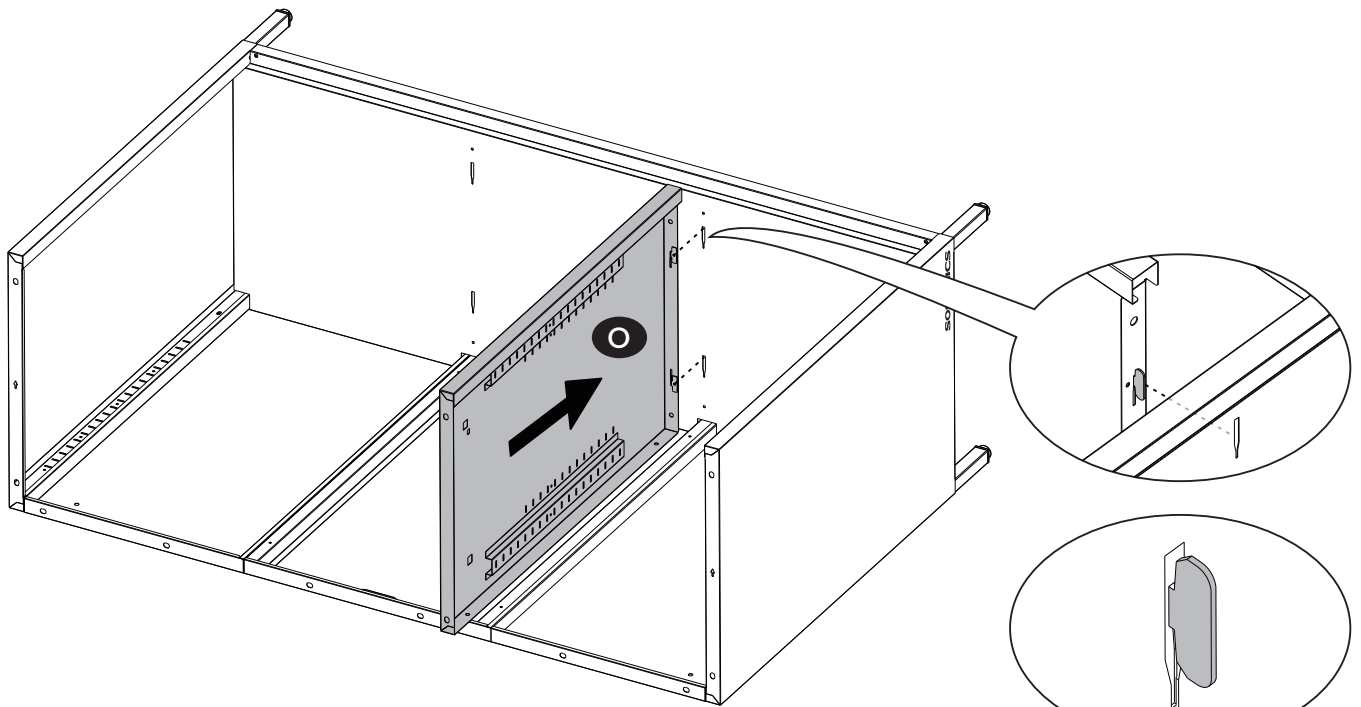

10

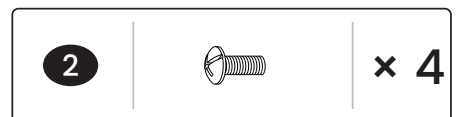
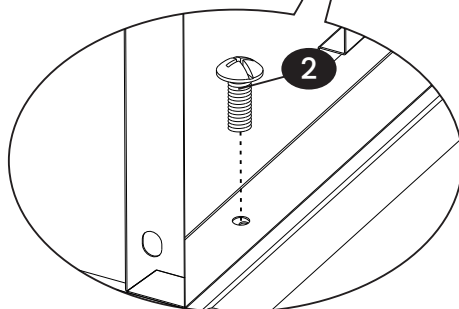
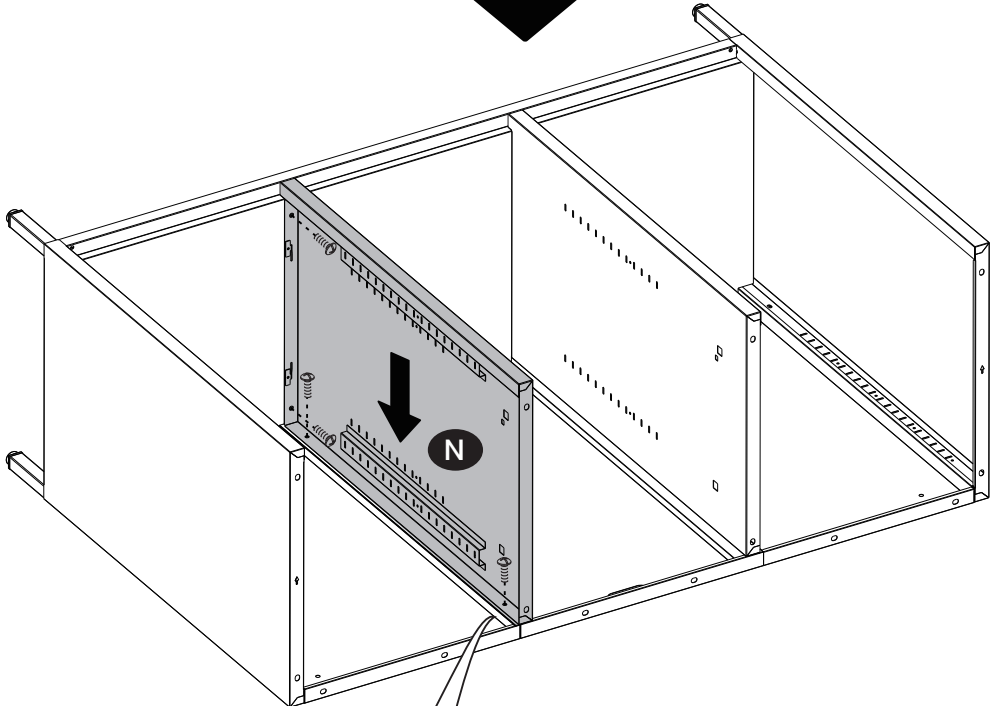
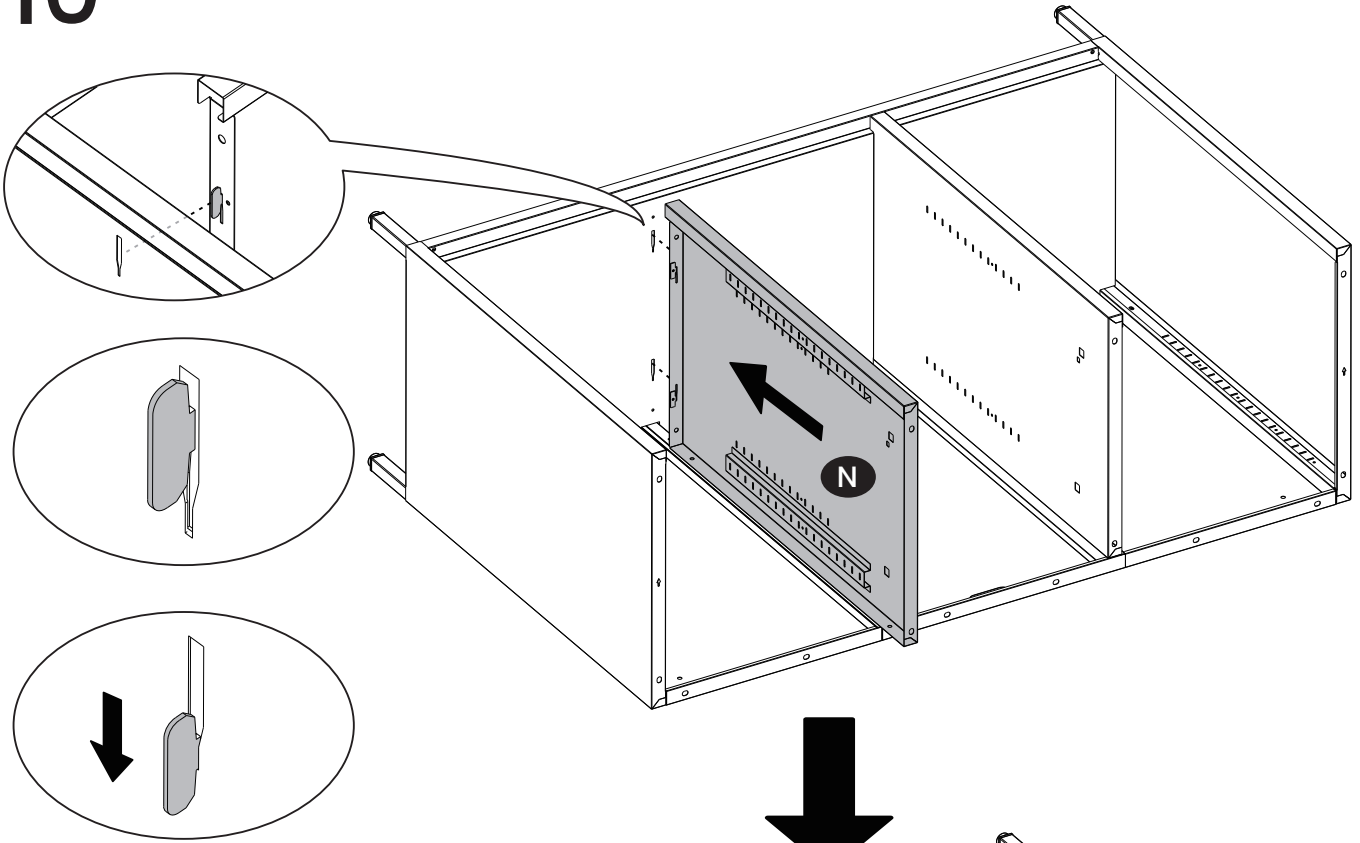

11

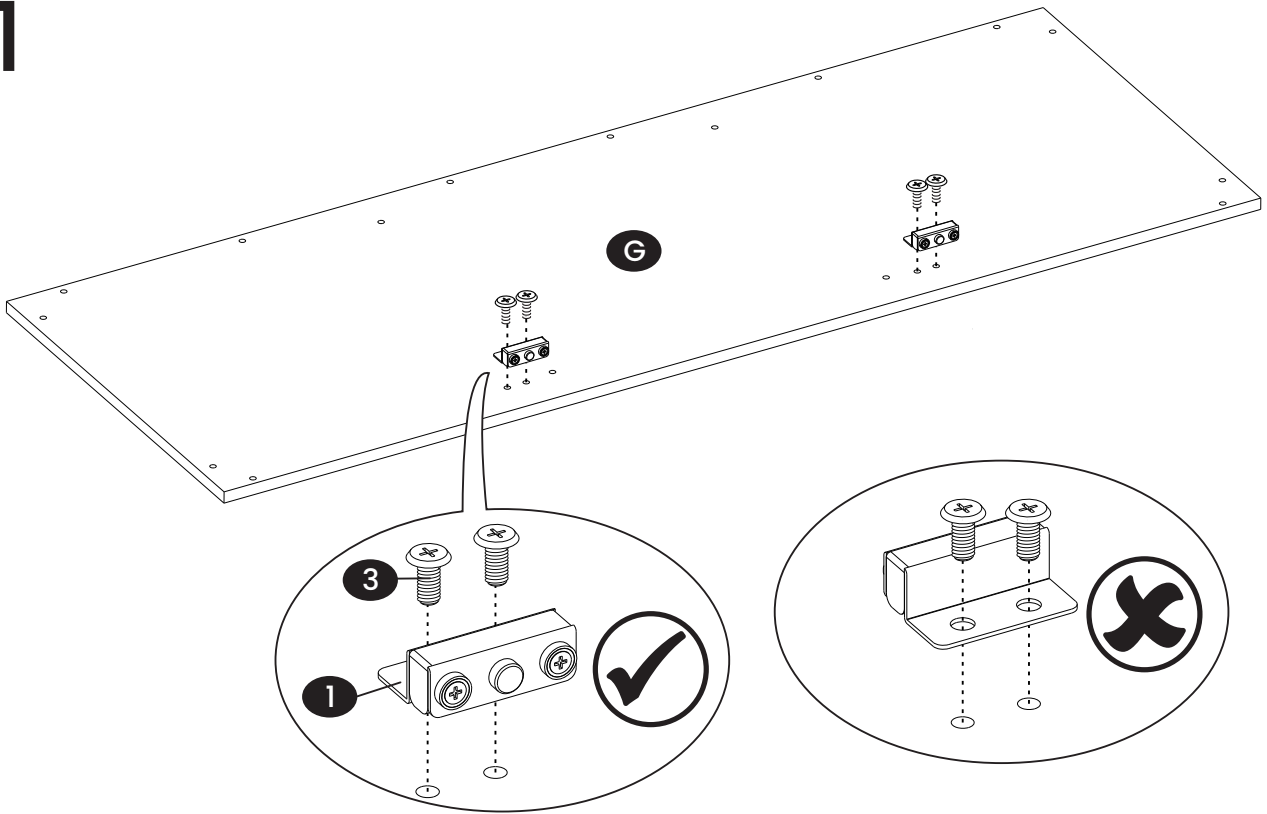

12

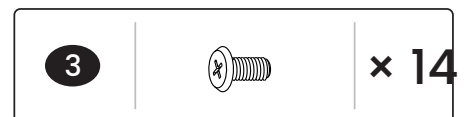
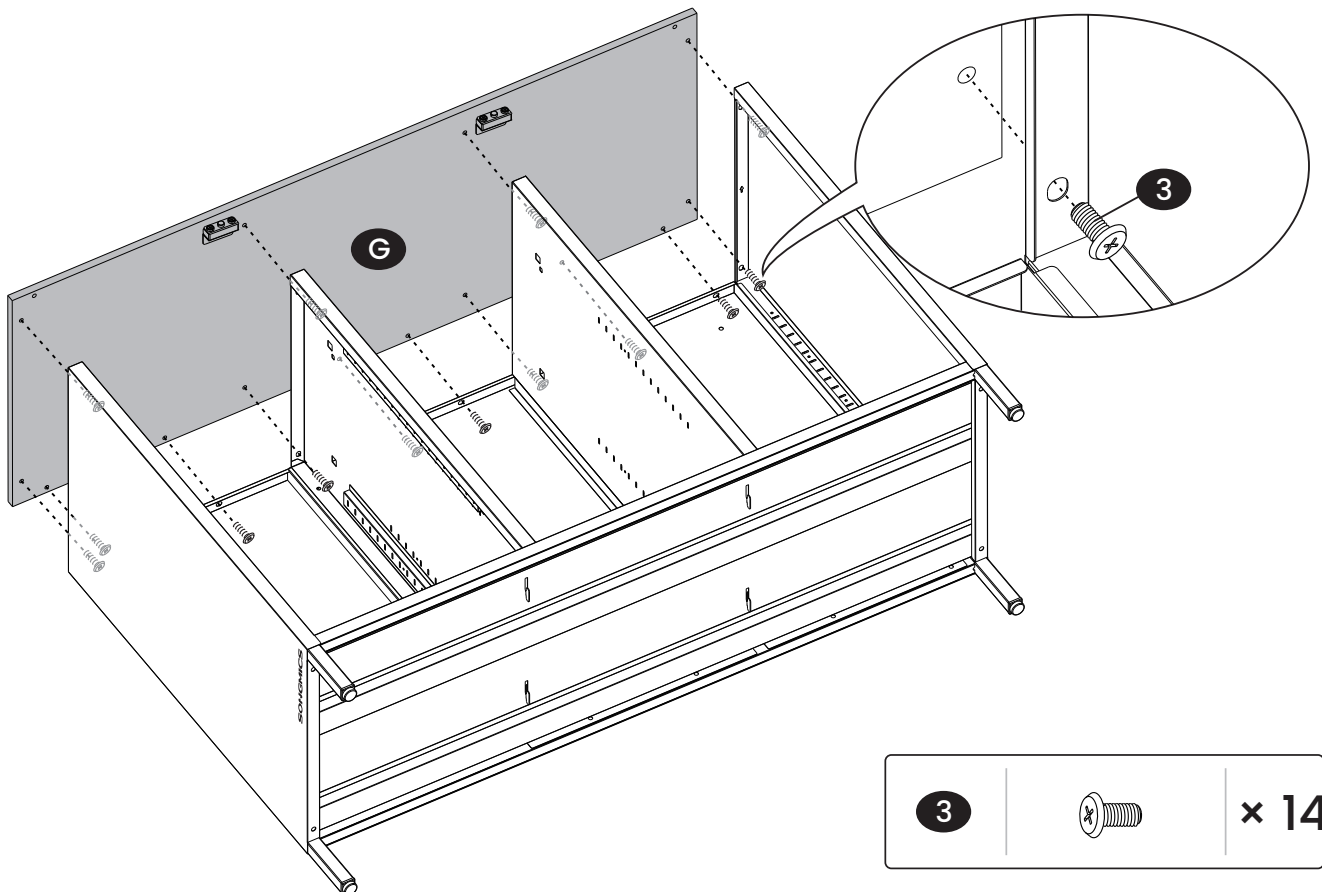

13

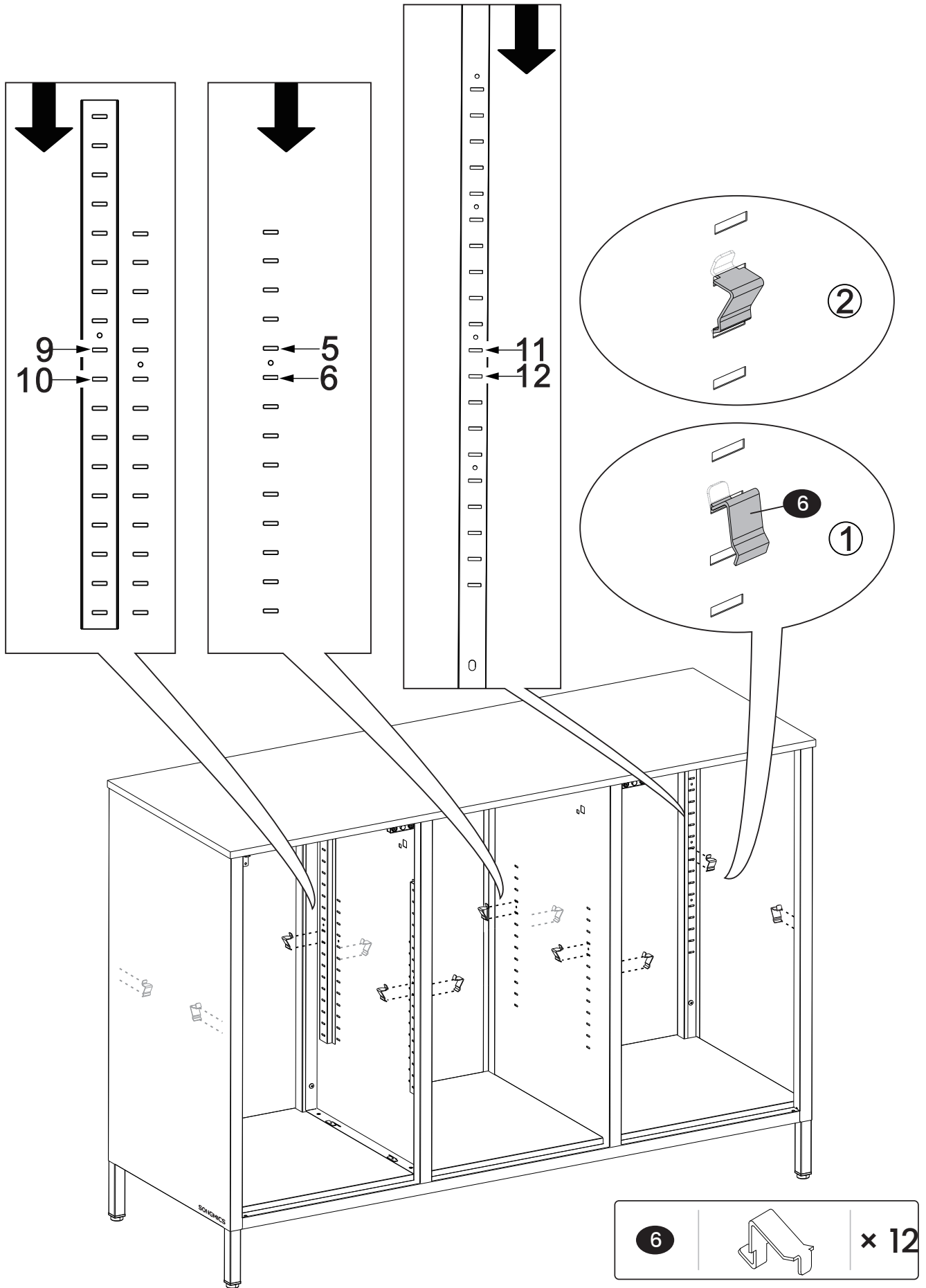

14

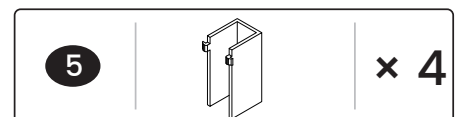
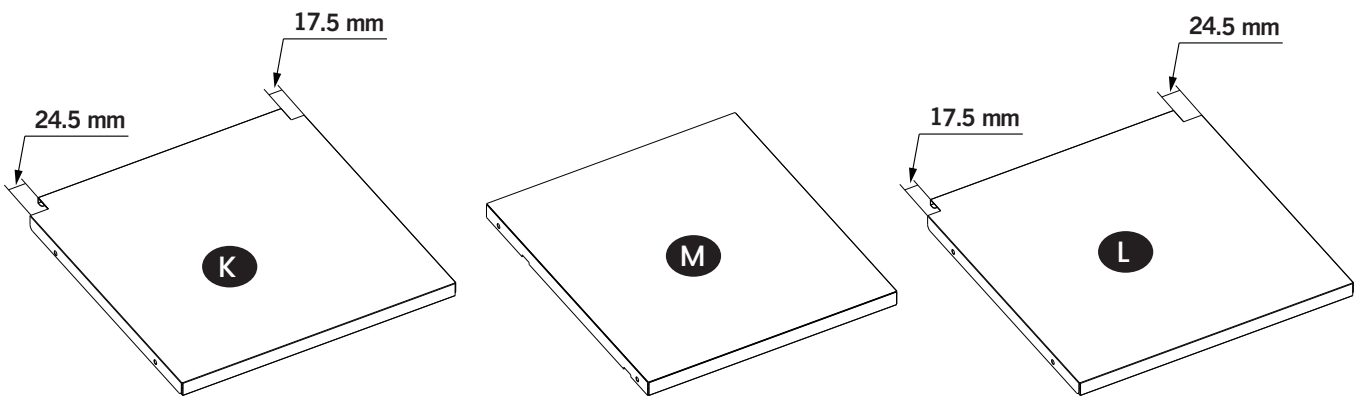
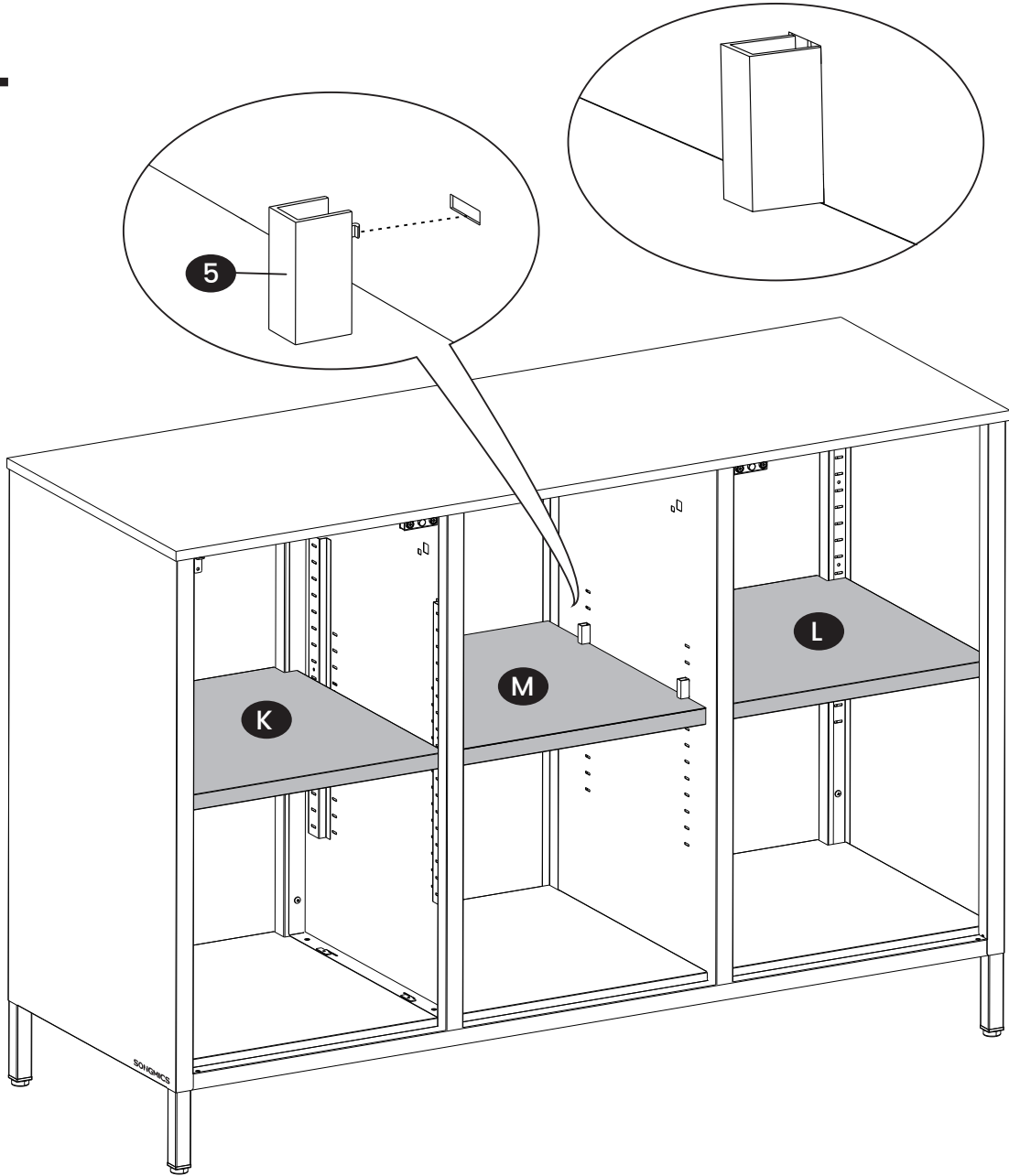

15

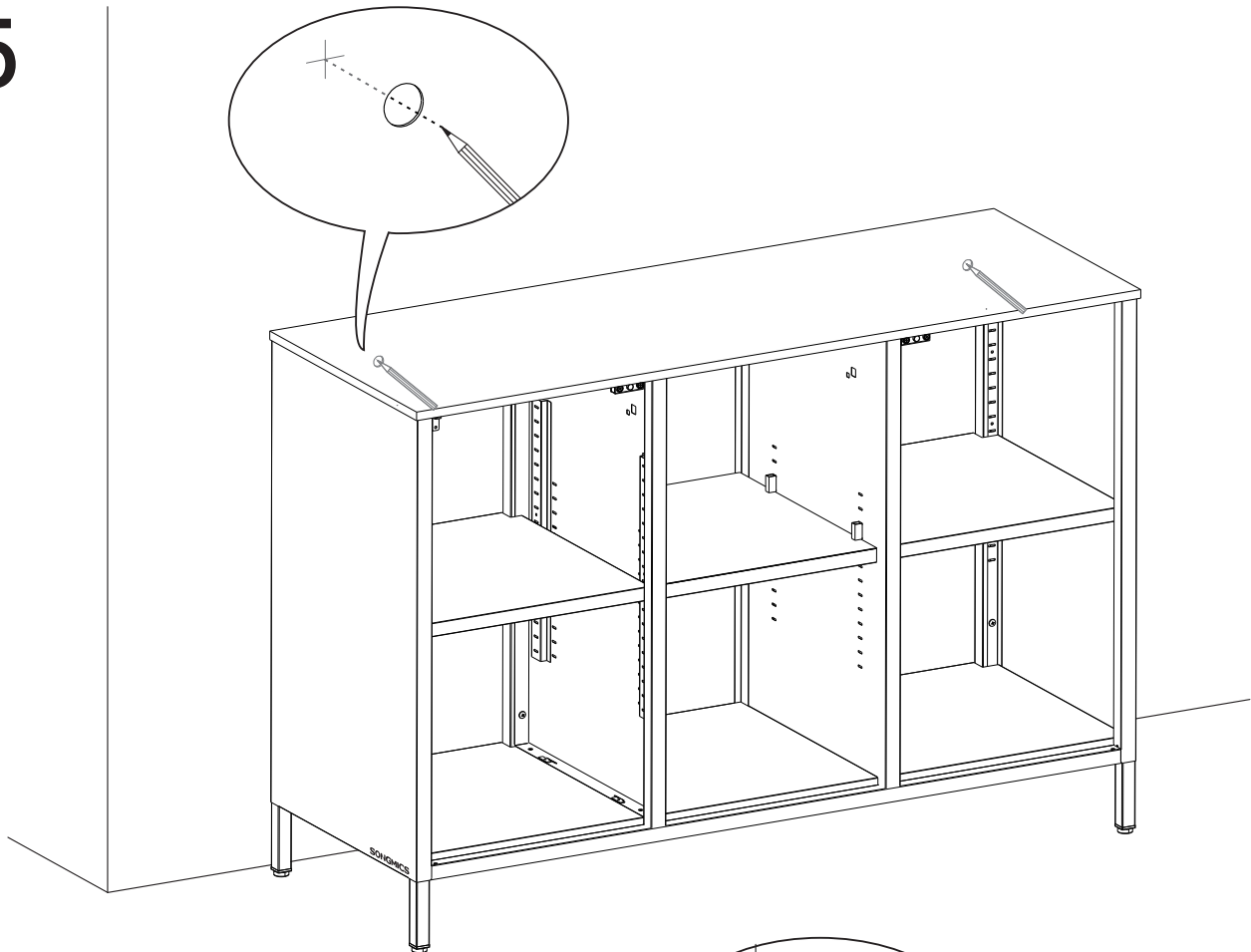

16

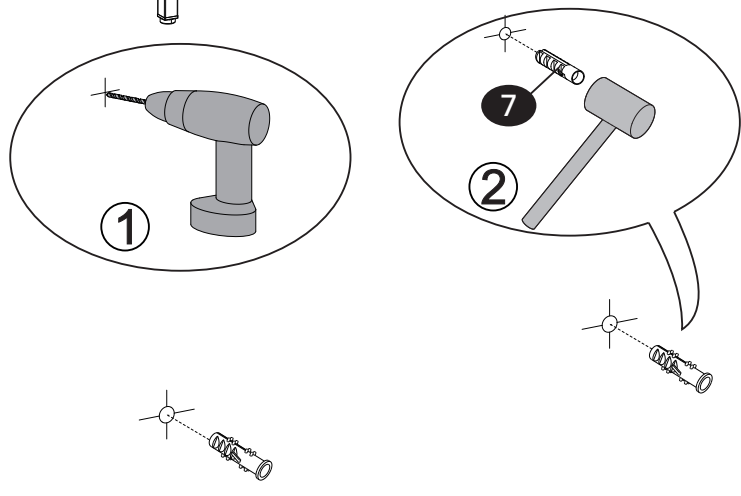

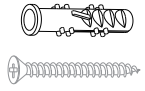
7		× 2
----------	---	------------

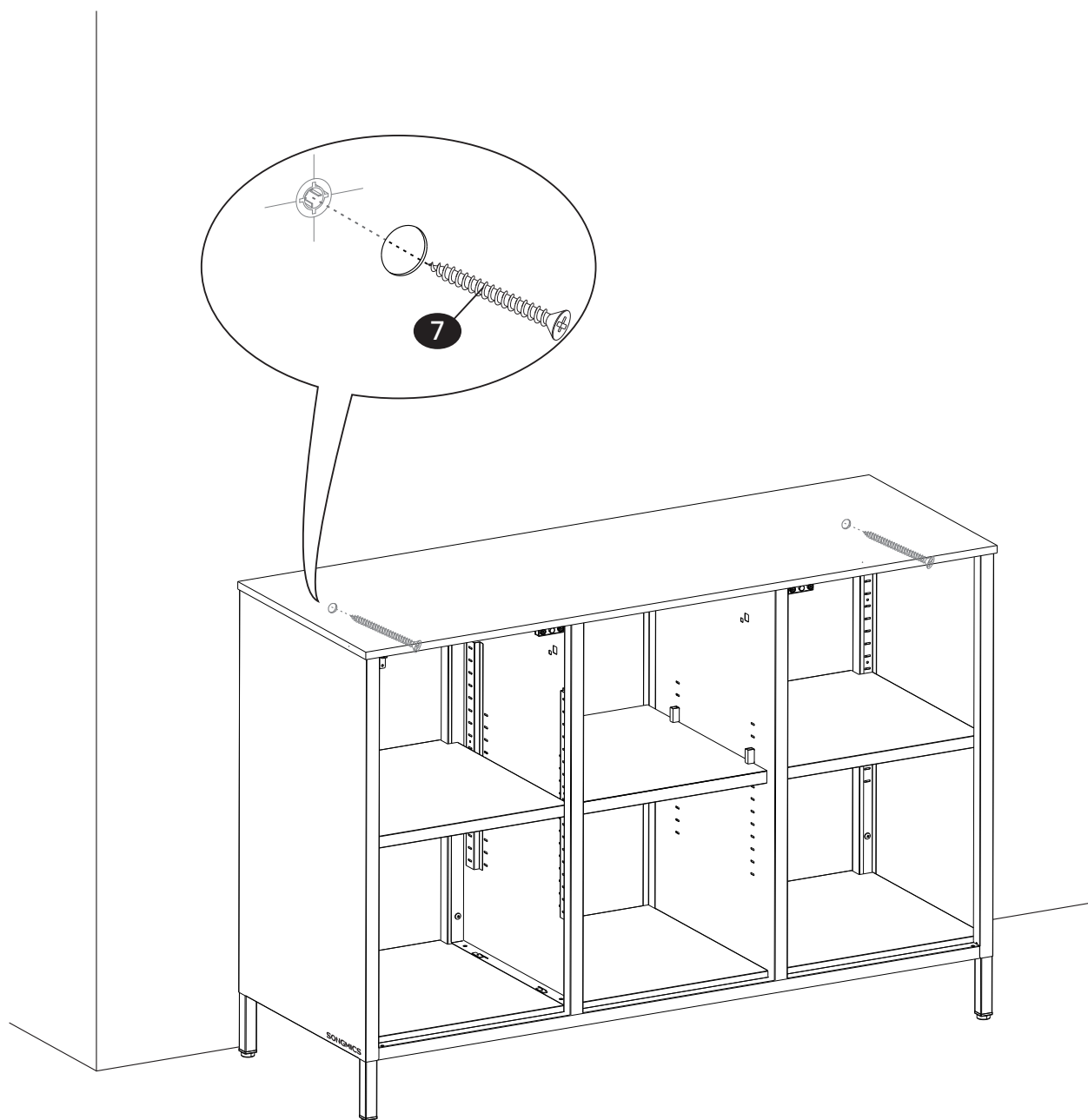

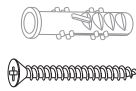
7		× 2
----------	---	------------

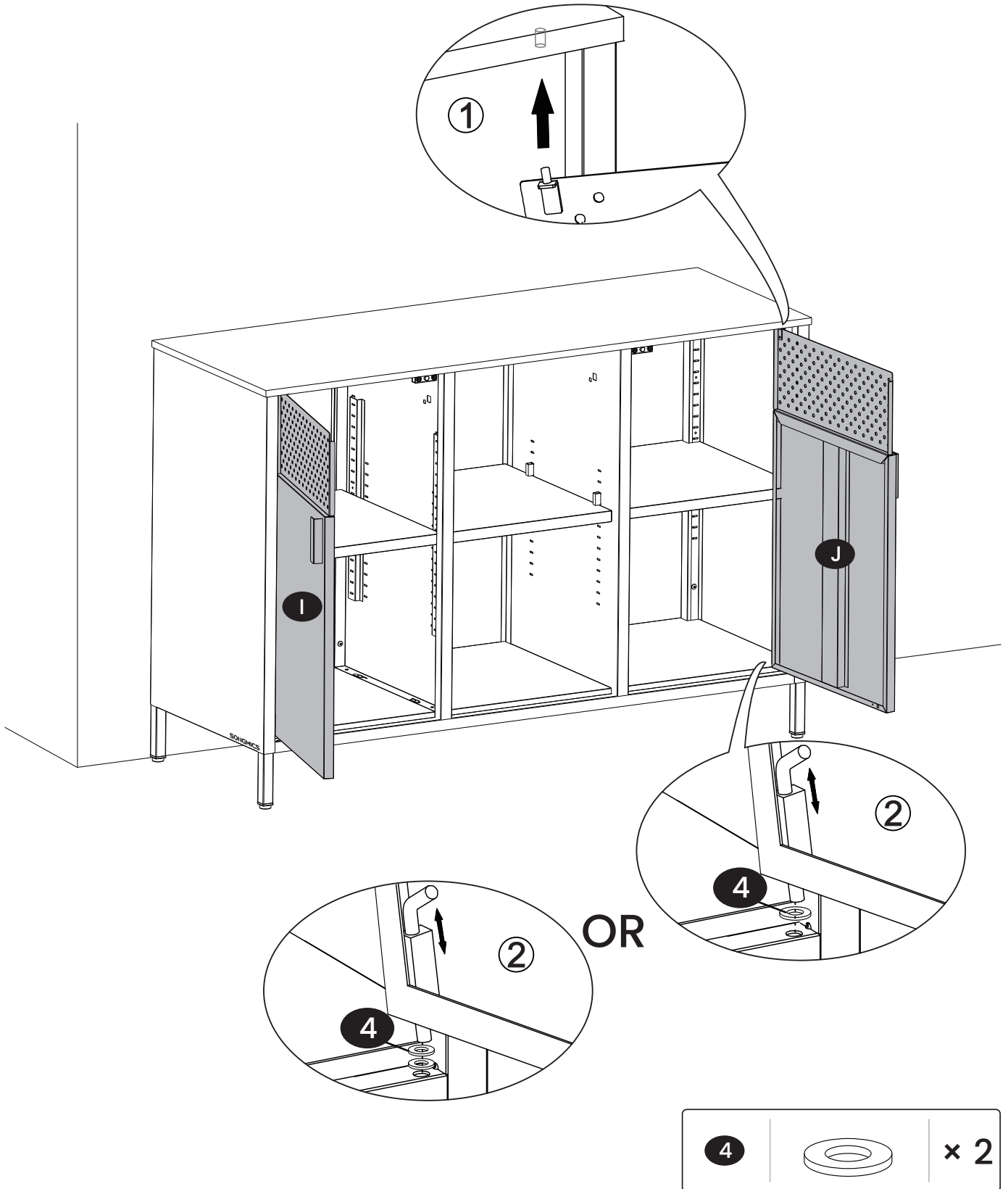

19

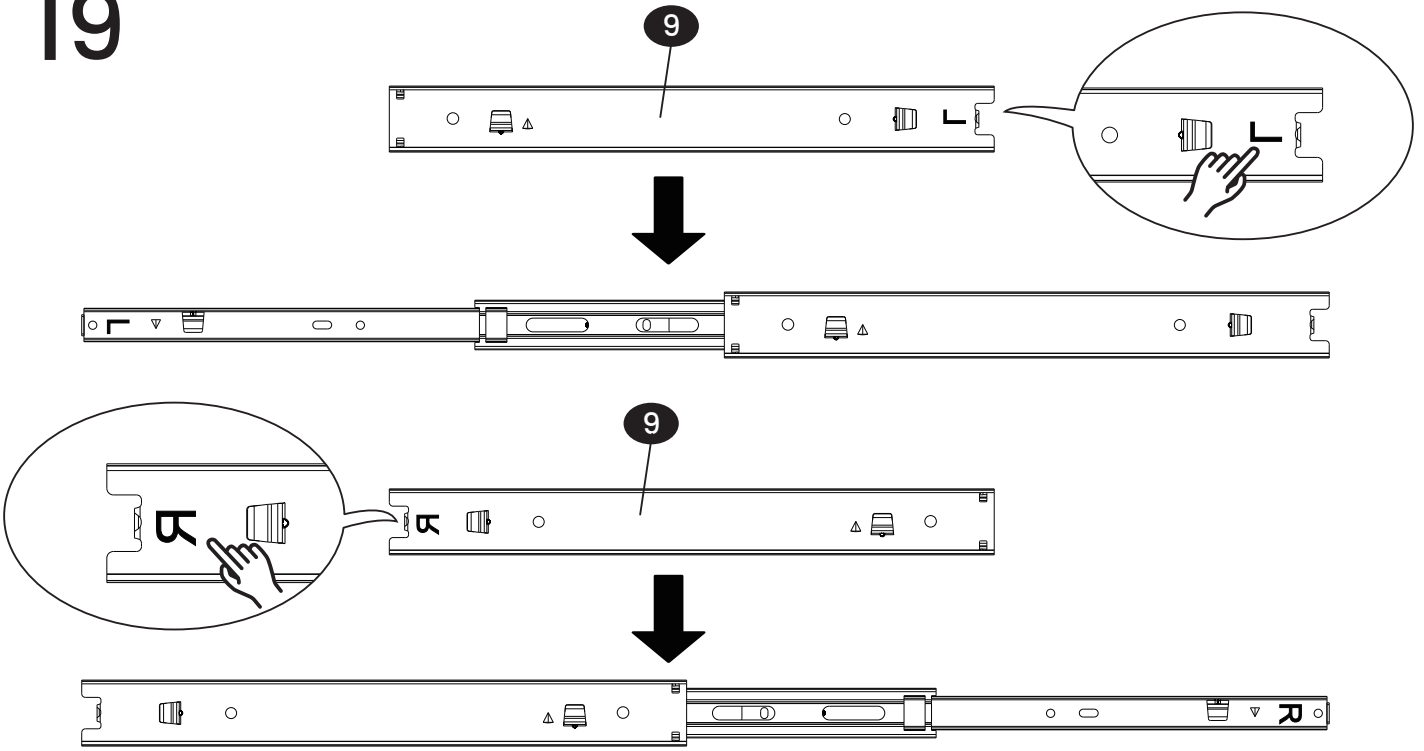

L

R

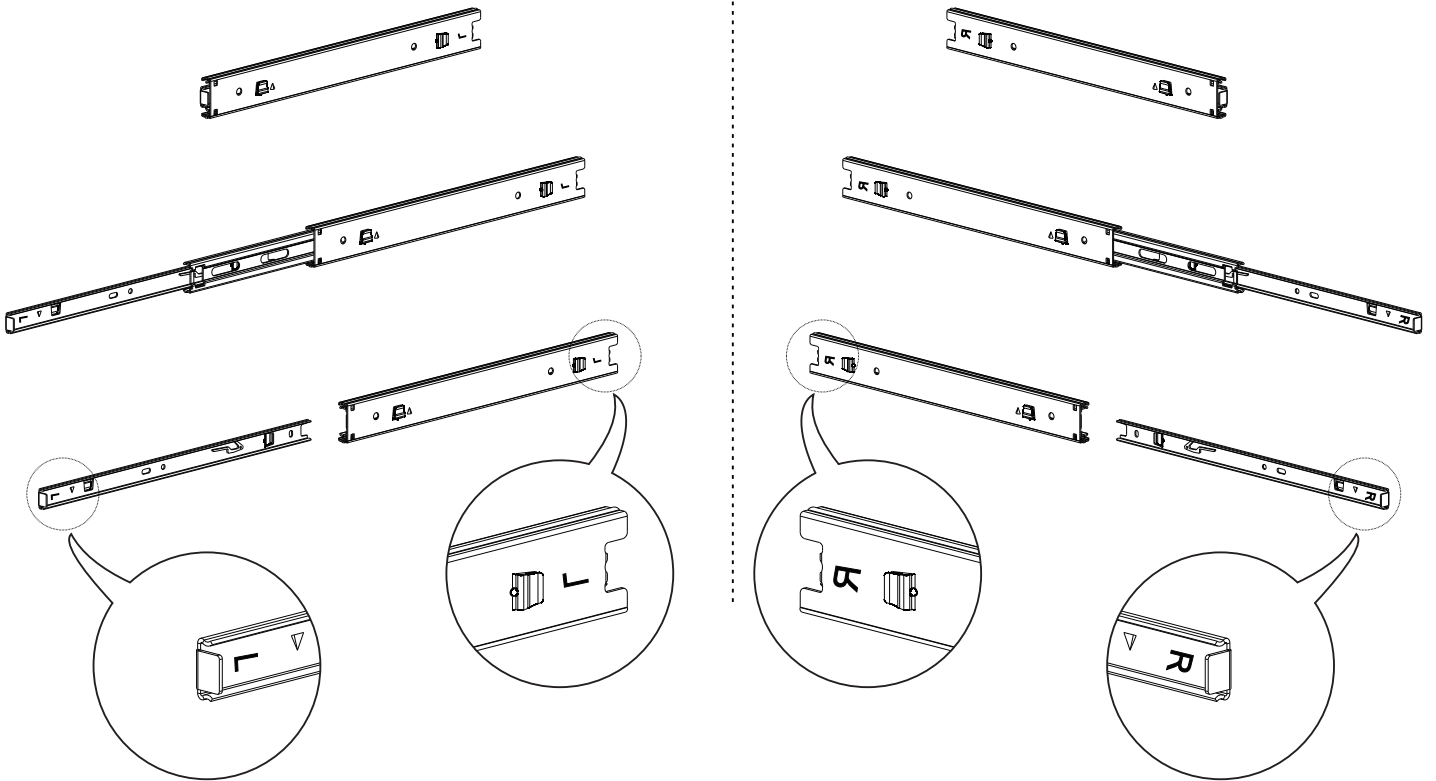

20

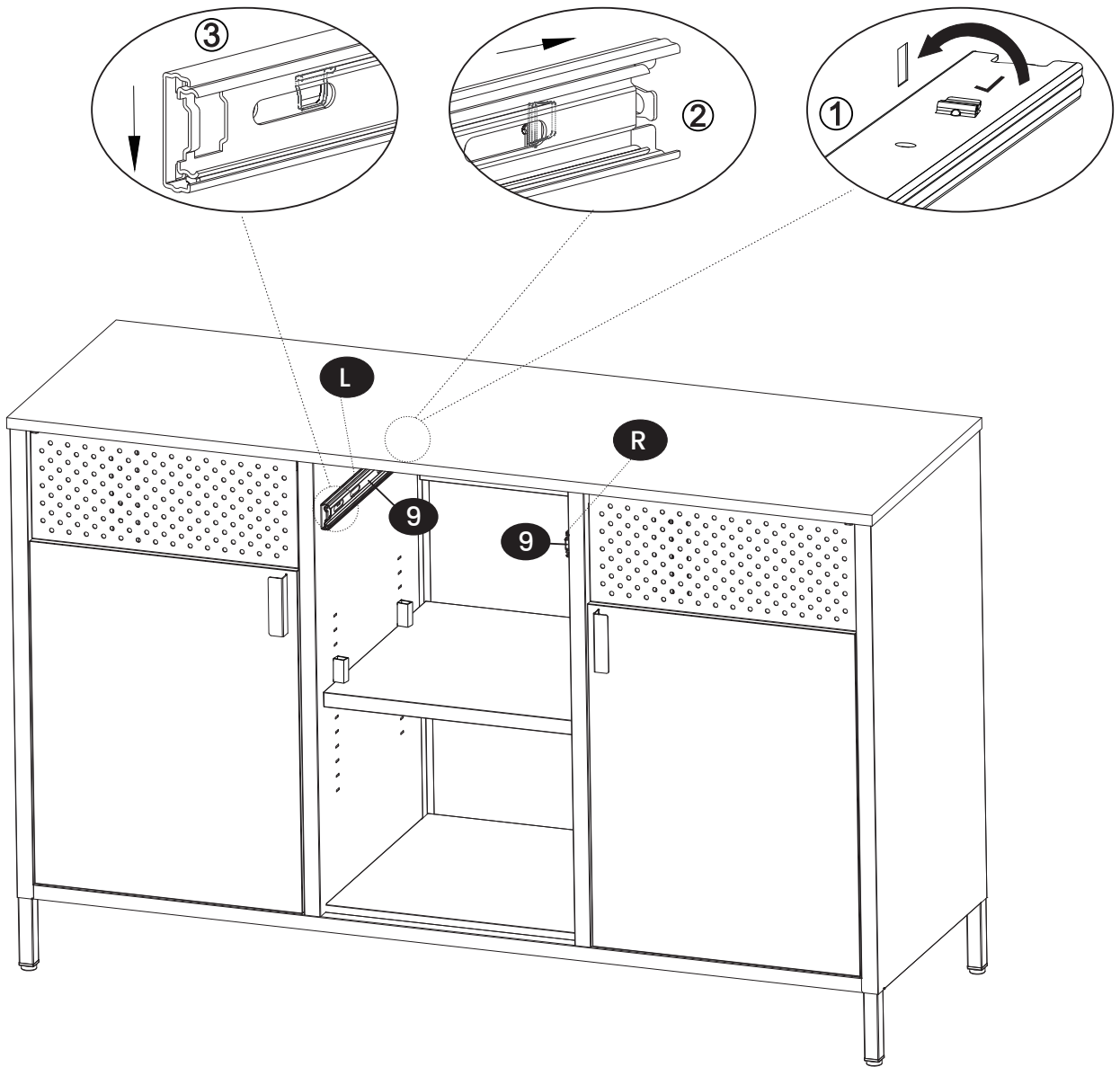

21

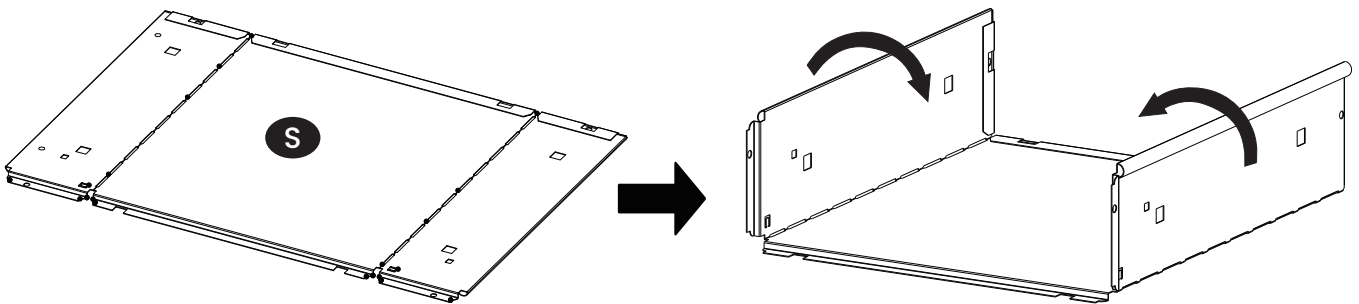

22

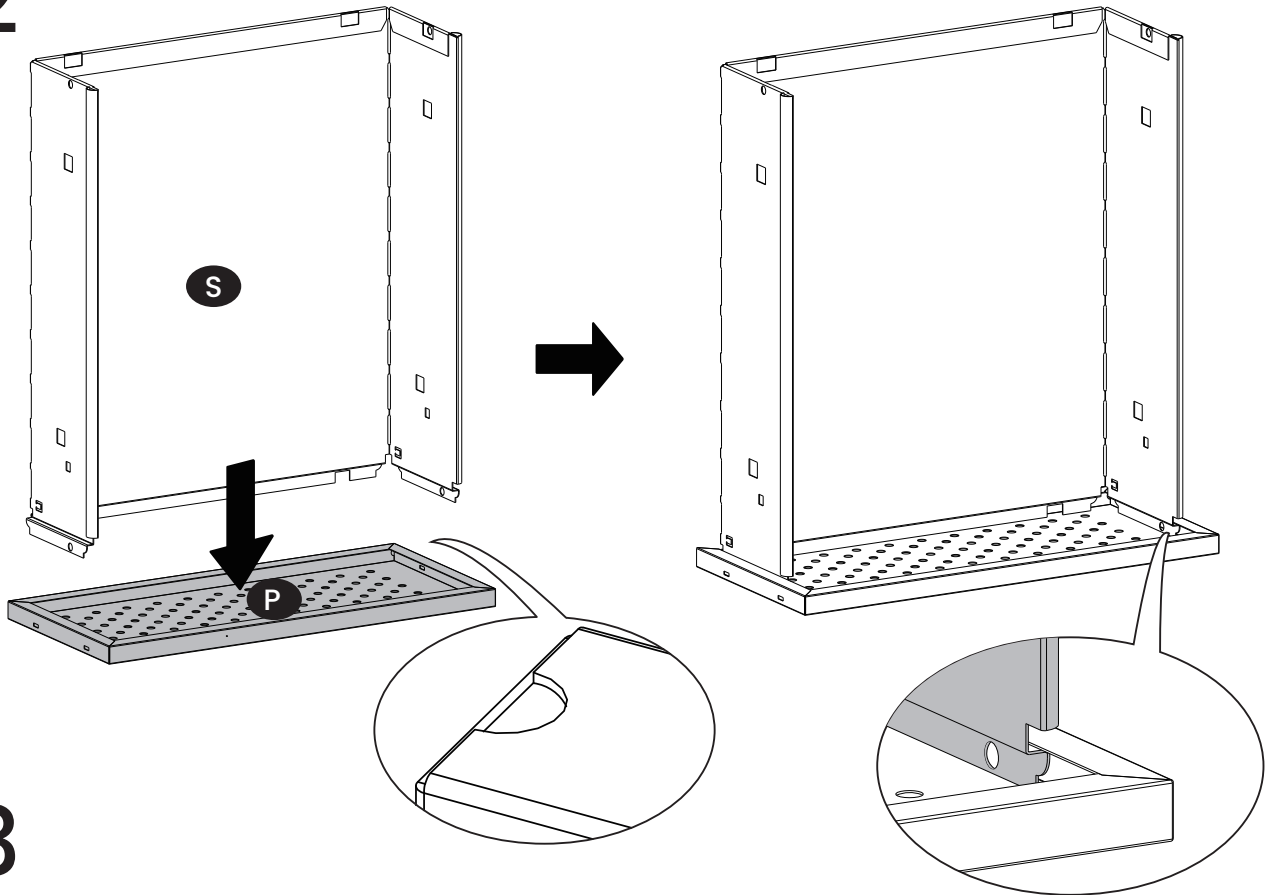

23

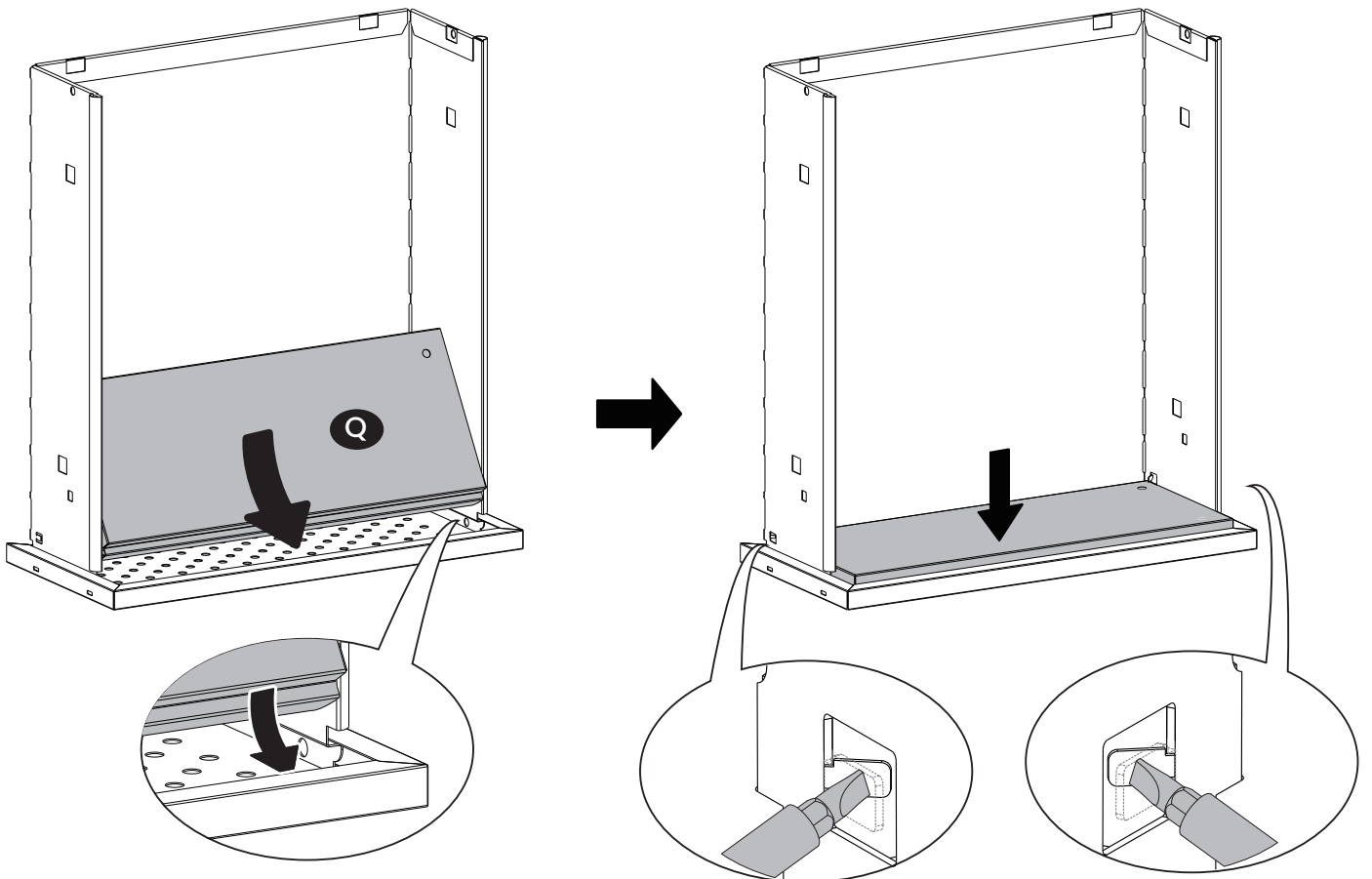

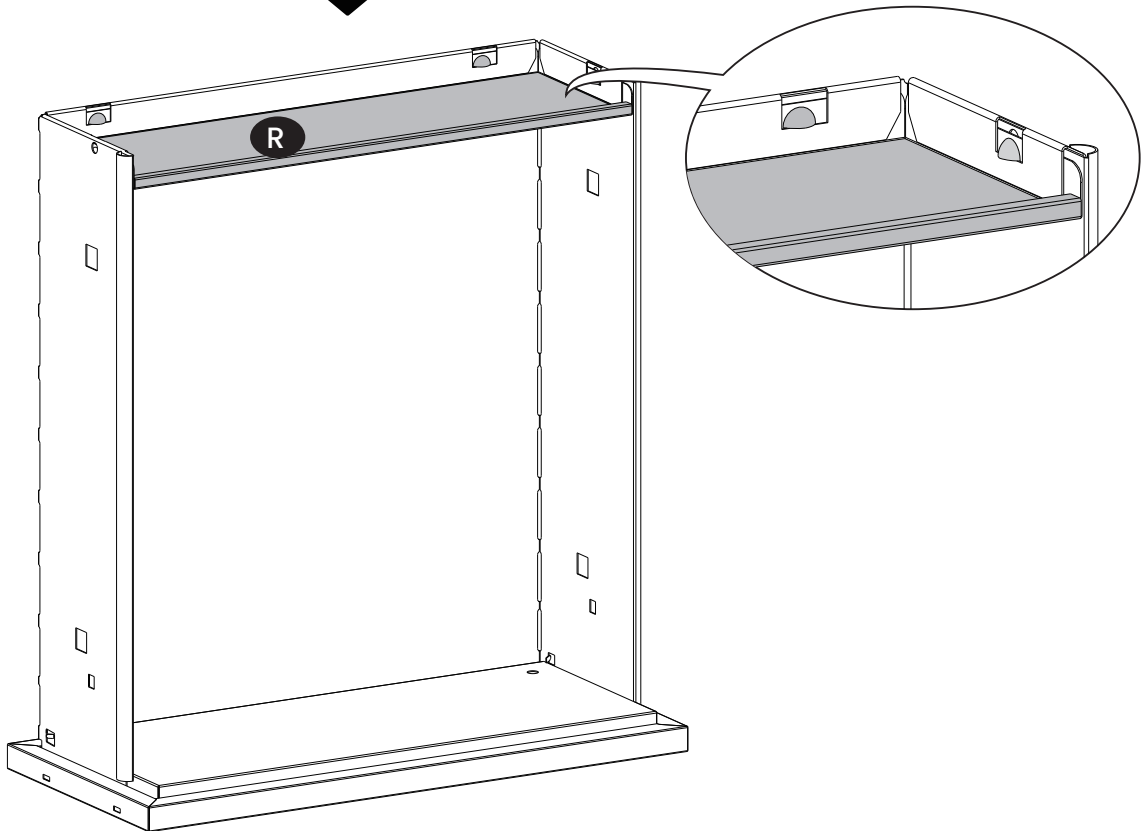
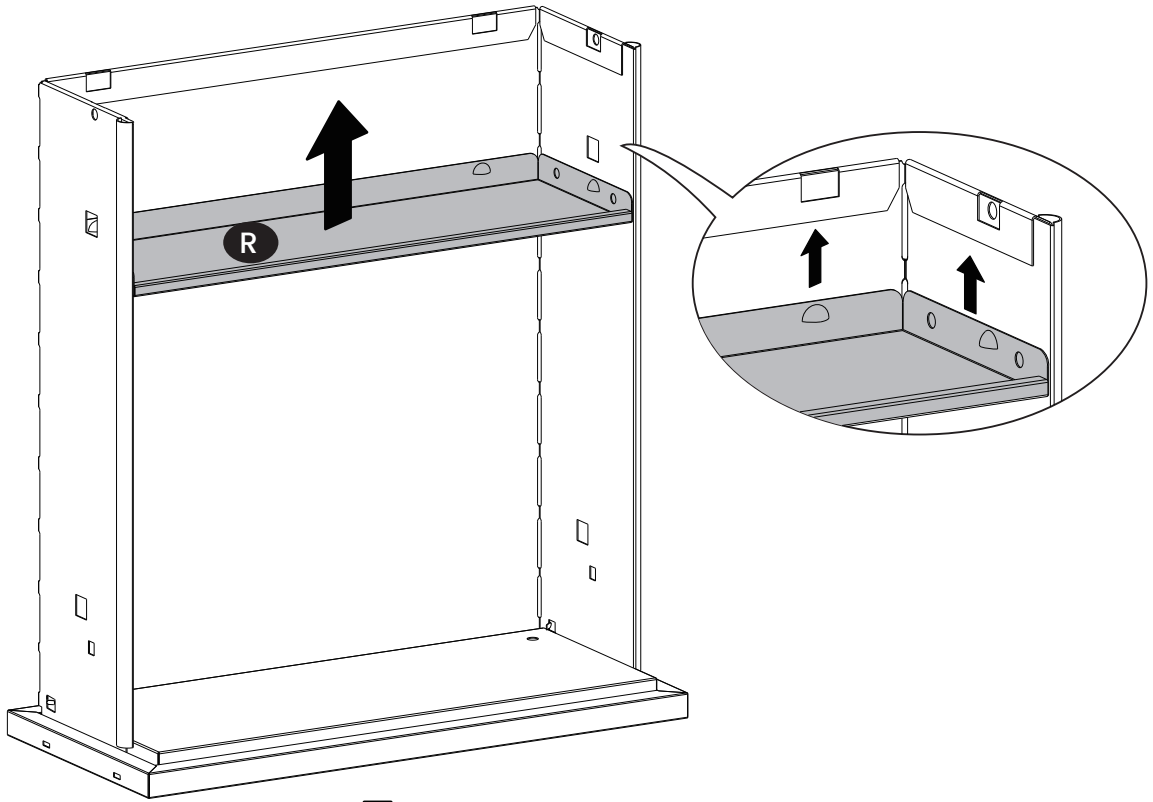

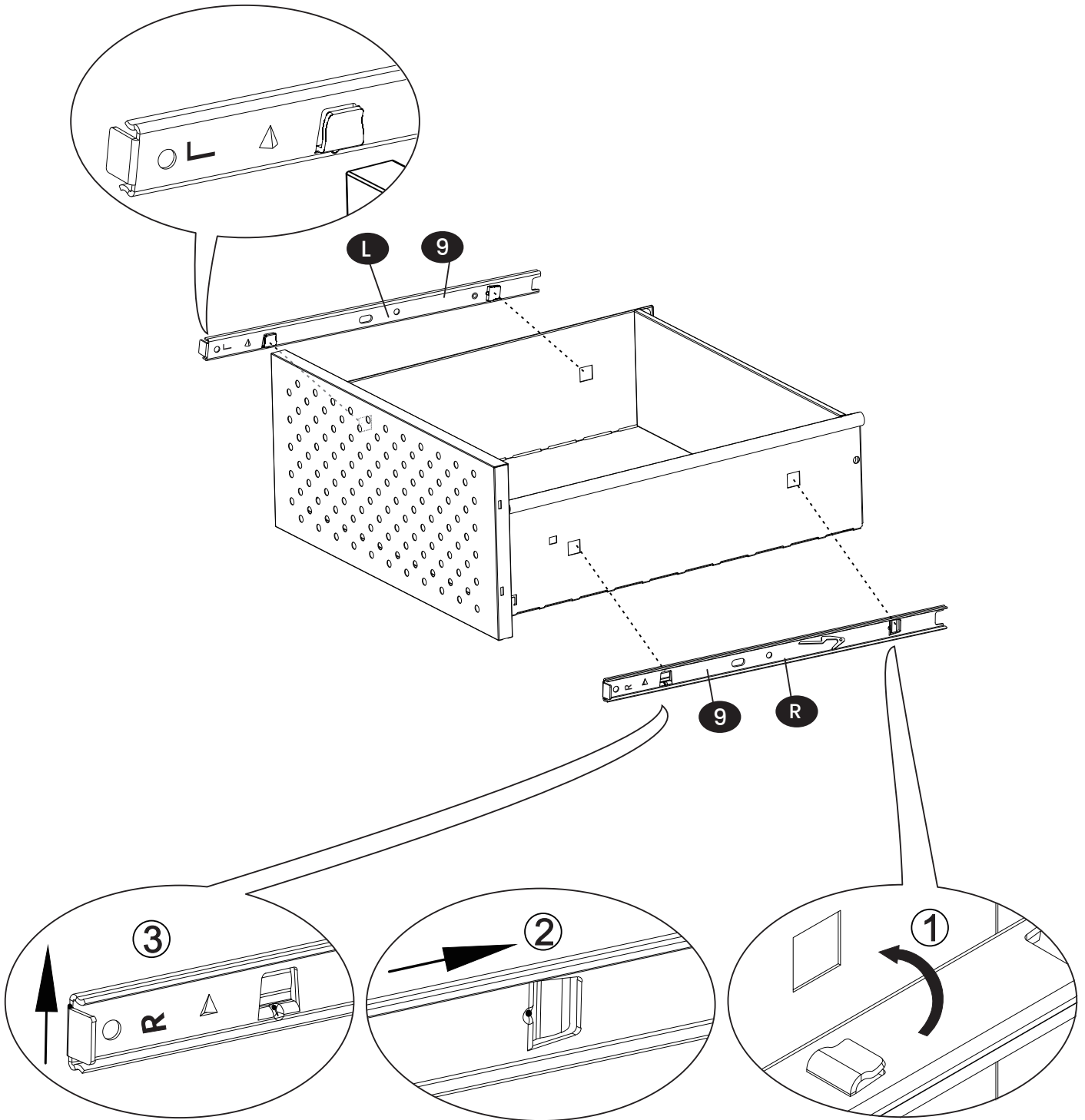

26

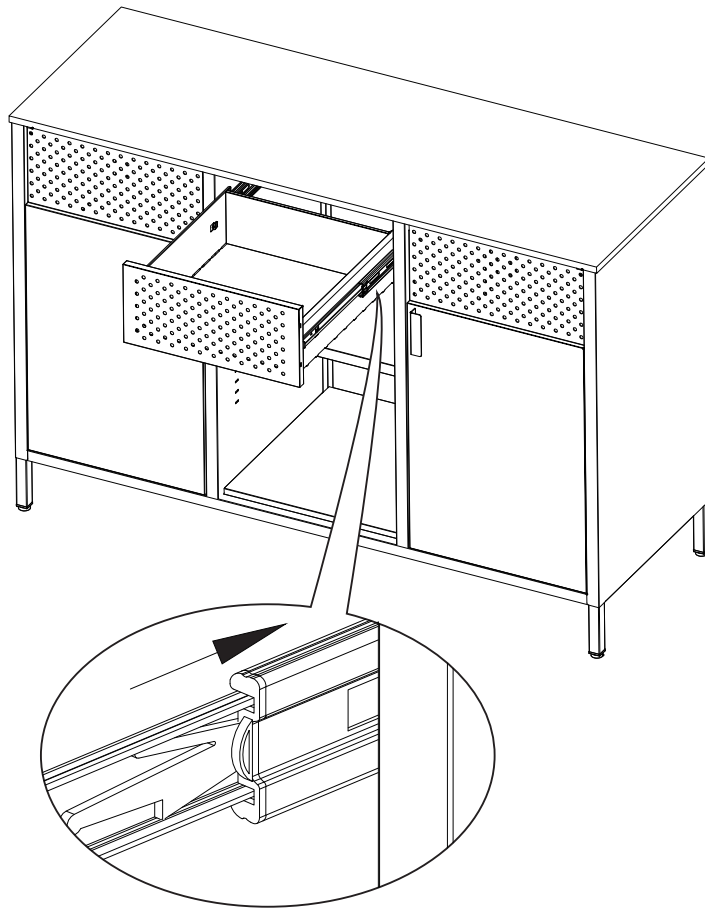

27

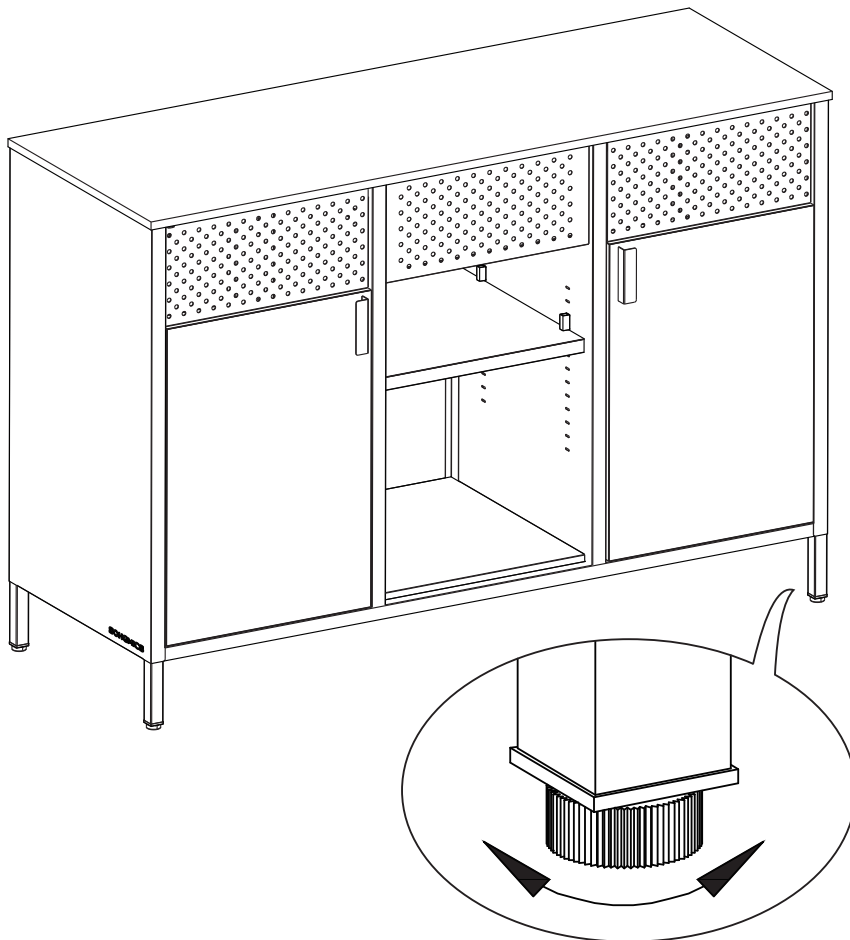



Please read the following instruction carefully and use the product accordingly.

Please keep this manual and hand it over when you transfer the product.

This summary may not include every detail of all variations and considered steps. Please contact us when further information and help are



It is recommended that two adults assemble the product. Please assemble this item strictly according to each step in the instructions.

During assembly, first loosely align all screws with the corresponding pre-drilled holes and then tighten the screws one by one.

Please use the product indoors and don't place it in a damp environment for extended periods of time to prevent mildew or rust.

Keep the product away from sharp objects or corrosive chemicals to prevent damage to the surface.

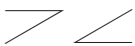

During assembly, keep all small parts out of the reach of children. It may be fatal if swallowed or inhaled.

Children are not allowed to climb or stand on the product to avoid personal injury caused by the product tilting or tipping over.

Please do not use the product if there is/are defective and/or missing part/s, as this can result in damage or injury.

To avoid the potential dangers of suffocation, please keep all parts and packaging (film, plastic bags, foam, etc.) away from babies and children.

The product should be attached to the wall with the included anti-tipping kits to prevent personal injury by accidentally tipping over.

The maximum load capacity of each shelf inside the cabinet is 18.1 kg (40 lb), and that of the top surface is 72.6 kg (160 lb). Please do not



Bitte lesen Sie die folgende Anleitung aufmerksam durch und verwenden Sie das Produkt sachgemäß.

Bewahren Sie diese Anleitung gut auf und händigen Sie sie bei Weitergabe des Produkts an Dritte ebenfalls mit aus.

Aus Gründen der Übersicht können nicht alle Details zu allen Varianten und denkbaren Montagen beschrieben werden. Wenn Sie weitere



Die Montage sollte von zwei Erwachsenen durchgeführt werden. Bauen Sie das Produkt bitte streng nach Anleitung auf.

Ziehen Sie die Schrauben bei der Montage bitte nicht sofort an. Erst nachdem Sie alle Schrauben eingesetzt haben, sollten Sie diese vorsichtig festziehen.

Das Produkt ist zum Gebrauch in Innenräumen vorgesehen. Stellen Sie es bitte nicht über einen längeren Zeitraum in einer feuchten Umgebung auf, um Schimmel und Rost zu vermeiden.

Das Produkt darf nicht in Kontakt mit scharfen Gegenständen und aggressiven chemischen Substanzen kommen, um Beschädigungen zu



Halten Sie Kinder während der Montage vom Arbeitsbereich fern. Zum Lieferumfang gehören viele Kleinteile, die beim Verschlucken oder Inhalieren lebensgefährlich sein können.

Um durch Umkippen verursachte Verletzungen zu vermeiden, dürfen sich Kinder unter keinen Umständen auf das Produkt stellen, auf dieses klettern oder damit spielen.

Verwenden Sie das Produkt bitte nicht, wenn Teile fehlen oder defekt sind.

Verwahren Sie Verpackungsteile nur an Orten, die Kindern nicht zugänglich sind. Verpackungsteile bergen oftmals nicht erkennbare Gefahren (z.B. Erstickungsgefahr).

Bevor Sie das Produkt benutzen, sollten Sie den mitgelieferten Kippschutz montieren, um durch Umkippen verursachte Verletzungen zu vermeiden.

Die max. Belastbarkeit pro Regalebene im Schrank beträgt 18,1 kg und die Oberfläche des Produktes ist mit bis zu 72,6 kg belastbar. Stellen Sie keine schwereren Gegenstände auf das Produkt.



δ



Lisez attentivement ces instructions et utilisez votre produit d'après ce mode d'emploi.

Conservez ces instructions. Si vous souhaitez offrir ce produit à un tiers, joignez obligatoirement ce mode d'emploi.

Pour des raisons de clarté, les détails concernant chaque variante ou montage envisageable ne peuvent être tous décrits. Si vous



Il est recommandé d'assembler ce produit par 2 adultes. Veuillez respecter scrupuleusement les étapes à montage soulignées dans ce mode d'emploi.

Lors du montage, veuillez positionner bien toutes les vis et les clous, ensuite effectuez un serrage progressif de l'ensemble des vis.

Veuillez utiliser ce produit à l'intérieur et ne pas le laisser dans un environnement humide pendant de longues périodes pour éviter la moisissure ou la rouille.

Évitez tout contact de ce produit avec les objets pointus et corrosifs qui peuvent endommager ce produit.



Les enfants ne sont pas autorisés à participer à l'assemblage de ce produit car il comprend de nombreuses petites pièces, l'inspiration ou l'ingestion de ces pièces présente un risque mortel.

Ne laissez pas les enfants monter ou jouer sur ce produit pour éviter les dommages causés par renversement.

Veuillez ne pas utiliser ce produit s'il y a des pièces défectueuses ou manquantes pour éviter les blessures corporelles.

Veuillez garder toutes les pièces et l'emballage (films, sacs plastiques, polystyrènes, etc.) hors de la portée des enfants pour éviter les dangers inattendus (par ex. L'étouffement).

Installez obligatoirement le dispositif anti-renversement pour éviter de le renverser.

La capacité de charge statique maximale de chaque planche à l'intérieur du placard est de 18.1 kg, celle du dessus est de 72.6 kg. Veuillez



Si prega di leggere attentamente le seguenti istruzioni e usare il prodotto in modo opportuno.

Si prega di conservare questo manuale e consegnarlo quando il prodotto cambia proprietario.

Questo riassunto potrebbe non includere ogni dettaglio di tutte le variazioni e le fasi considerate. Contattaci se hai bisogno di ulteriori



L'assemblaggio del prodotto dovrebbe essere effettuato da due persone. Si prega di assemblare questo prodotto seguendo le istruzioni passo passo.

Durante l'assemblaggio, allineare tutte le viti con i fori corrispondenti e serrarle una per una.

Per evitare la formazione di muffa o ruggine, si consiglia di utilizzare il prodotto in ambienti chiusi e di non collocarlo in ambienti umidi per lunghi periodi di tempo.

Si prega di tenere il prodotto lontano da oggetti appuntiti o da sostanze chimiche corrosive per evitare di danneggiare la superficie.



Durante il montaggio, tenere tutte le parti piccole fuori dalla portata dei bambini. Può essere fatale se ingerito o inalato.

I bambini non possono arrampicarsi o stare in piedi sul prodotto per evitare lesioni personali causate dal ribaltamento del prodotto.

Non utilizzare il prodotto in presenza di uno o più componenti difettosi e/o mancanti, in quanto ciò potrebbe causare danni o lesioni.

Per evitare i potenziali pericoli di soffocamento, tenere tutte le parti e l'imballaggio (pellicola, sacchetti di plastica, gommapiuma, ecc.) lontano da neonati e bambini.

Il prodotto deve essere fissato alla parete con il kit antiribaltamento in dotazione per evitare lesioni personali dovute al ribaltamento accidentale.

La portata massima di ogni ripiano all'interno dell'armadio è di 18.1 kg, mentre quella del piano superiore è di 72.6 kg. Non collocare oggetti in sovrappeso sul prodotto.



Por favor, lea detenidamente las instrucciones y respete los debidos usos del producto.

Por favor, conserve bien este manual y en caso de cesión, no omita entregarlo junto al producto.

Este manual podría no incluir todos los detalles de cada paso del montaje. Si necesita ayuda o información adicional, póngase en



Se recomienda que dos adultos ensamblen el producto. Por favor, ensamble este artículo estrictamente de acuerdo a cada paso de las instrucciones.

Durante el montaje, alinee primero todos los tornillos con los orificios pretaladrados correspondientes y, a continuación, apriete los tornillos uno por uno.

Por favor, use el producto en interiores, y no lo coloque en un ambiente húmedo durante mucho tiempo para evitar el moho.

Mantenga el producto alejado de objetos punzantes o productos químicos corrosivos para evitar daños en la superficie.



Durante el montaje, mantenga todas las piezas pequeñas fuera del alcance de los niños. Puede ser mortal si se ingiere o inhala.

No se permite que los niños se suban o se suban al producto para evitar lesiones personales causadas por la inclinación o vuelco del producto.

Por favor, no utilice el producto si está defectuoso y/o le faltan piezas, ya que esto puede ocasionar daños o lesiones.

Para evitar los peligros potenciales de asfixia, mantenga todas las piezas y embalajes (películas, bolsas de plástico, espuma, etc.) fuera del alcance de los bebés y los niños.

El producto debe fijarse a la pared con el dispositivo de fijación incluido para evitar lesiones personales en caso de vuelco accidental.

La capacidad de carga máxima de cada estante dentro del gabinete es de 18.1 kg, y la de la superficie superior es de 72.6 kg. Por favor, no coloque artículos con sobrepeso en el producto.



Gelieve de handleiding na te lezen en het product conform de instructies te gebruiken.

Gelieve de handleiding bij het product te houden en bij verkoop mee te geven aan de nieuwe gebruiker.

Deze samenvatting bevat mogelijk niet alle variaties en stappen. Gelieve contact op te nemen indien u meer informatie of hulp nodig hebt.



Het is aanbevolen dat twee mensen het product in elkaar steken. Gelieve het product in elkaar te steken volgens de stappen in de handleiding.

Tijdens het in elkaar steken, maakt u de schroeven lichtjes vast, nadien mag u deze goed vastdraaien.

Gebruik het product binnen en plaats het niet in vochtige omgeving voor een lange periode om schimmel of roest te voorkomen.

Hou het product uit de buurt van scherpe onderwerpen en bijtende chemische product om schade aan het oppervlakte te vermijden.

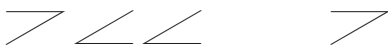

Tijdens het in elkaar steken, hou de kleine onderdelen uit de buurt van de kinderen. Het inslikken van deze onderdelen kan stikgevaar veroorzaken.

Kinderen mogen niet klimmen of staan op het product om persoonlijk letsel te voorkomen.

Gebruik het product niet indien er ontbrekende of defectieve onderdelen zijn om potentiële schade te vermijden.

Om potentieel gevaar van stikken te vermijden, gelieve alle verpakkingen (plastiek zakken, isomo, etc.) buiten bereik van babies en kinderen te houden.

Het product dient vast gemaakt te worden aan de muur met de bevestigingspunten tijdens het gebruik om schade te vermijden.

De maximale statische draagcapaciteit van elk schap binnen het kastje is 18.1 kg, en het bovenste oppervlakte is 72.6 kg. Plaats geen



Var god läs följande instruktioner noggrant och använd produkten därefter.

Var god behåll den här bruksanvisningen och överlämna den när du överför produkten.

Denna sammanfattning kanske inte innehåller alla detaljer i alla variationer och övervägda steg. Vänligen kontakta oss när ytterligare



Det rekommenderas att två vuxna monterar produkten. Var god montera denna artikel strikt enligt varje steg i instruktionerna.

Rikta först in alla skruvar löst med de motsvarande förborrade hålen under montering och dra sedan åt skruvarna en efter en.

Använd produkten inomhus och placera den inte i fuktig miljö under längre tidsperioder för att förhindra mögel eller rost.

Håll produkten borta från vassa föremål eller frätande kemikalier för att förhindra skada på ytan.



Håll små delar utom räckhåll för barn under montering. De kan vara livsfarliga om de sväljs eller inandas.

Barn får inte klättra eller stå på produkten för att undvika personskada orsakad av att produkten tippas eller välter.

Använd inte produkten om det finns defekt/a del/ar eller del/ar som saknas eftersom detta kan medföra sak- eller personskada.

Håll alla delar och förpackningar (filmer, plastpåsar och skum, etc.) borta från bebisar och barn för att undvika potentiella risker för kvävning.

Produkten ska fästas i väggen med de medföljande tipskyddssatserna för att förhindra personskada genom oavsiktlig tippning.



Proszę uważnie przeczytać niniejsze instrukcje oraz odpowiednio używać produkt.

Proszę przechowywać tę instrukcję oraz przekazać razem z produktem podczas transferu zmiany własności.

Podsumowanie to może nie zawierać wszystkich detali każdej z wersji oraz uwzględnionych kroków. Proszę skontaktuj się z nami jeśli

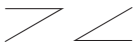

Rekomendowane jest złożenie produktu przez dwie osoby dorosłe. Proszę złożyć przedmiot ściśle według każdego kroku opisanego w tej instrukcji.

Podczas złożenia, ułóż wszystkie śruby do odpowiednich, wstępnie wywierconych otworów, a później dokręć śruby jedna po drugiej.

Proszę używać ten produkt wewnątrz oraz nie umieszczać tego produktu w warunkach wilgotnych przez dłuższy okres czasu, aby zapobiec wystąpieniu pleśni lub rdzy.

Trzymać produkt z daleka od ostrych obiektów lub chemii korozyjnej, aby zapobiec uszkodzeniu powierzchni.

Okresowo sprawdzaj docisk śrub, kiedy produkt jest już użytkowany. Jeśli wymaga tego sytuacja, docisnąć aby zapewnić integralność struktury.



Podczas złożenia, trzymać wszystkie małe części z daleka od zasięgu dzieci. Połknięcie lub wejście w drogi oddechowe może okazać się śmiertelne.

Zabronione jest wspinanie się lub stanie dzieci na produkcie tak, aby uniknąć urazów ciała wynikających z przechylenia się lub przewrócenia.

Nie używać produktu, gdy brakuje jakiegokolwiek części/i oraz/lub posiada/posiadają ona defekt, gdyż może to doprowadzić do uszkodzeń lub urazów.

Aby zapobiec potencjalnego zagrożenia uduszeniem się, proszę trzymać wszystkie części oraz opakowanie (folia, plastikowe torby, pianka itp.) z dala od niemowlaków oraz dzieci.

Produkt ten powinien być zamocowany do ściany za pomocą zatączonych przeciw-spadkowych elementów mocujących, aby uniknąć urazów ciała, spowodowanych przez przypadkowe przewrócenie.



İLütfen aşğıdaki talimatları dikkatlice okuyun ve ürünü belirtildiğı şekilde kullanın.

İLütfen bu kılavuzu saklayın ve ürünü teslim ederken karşı tarafa verin.

İBu özet, tüm varyasyonları ve dikkate alınan adımları bütünüyle içermeyebilir. Ek bilgi veya yardım gerekirse lütfen bizimle iletişime geçin.



Ürün montajı için iki yetişkin tavsiye edilir. Lütfen bu öğeyi verilen talimatları izleyerek monte edin.

Montaj sırasında, tüm vidaları karşılık gelen önceden delinmiş deliklerle gevşek bir şekilde hizalayın ve ardından her bir vidayı ayrı ayrı sıkın.

Küflenmeyi ve paslanmayı önlemek için lütfen ürünü iç mekanlarda kullanın ve uzun süre nemli bir ortama yerleştirmekten kaçının.

Yüzey hasarını önlemek için ürünü keskin nesnelere ve aşındırıcı maddelerden uzak tutun.

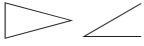

Montaj sırasında tüm küçük parçaları çocukların erişemeyeceğı bir yerde saklayın. Yutulması veya solunması halinde ölümcül olabilir.

Ürünün eğilmesi veya devrilmesinden kaynaklanan kişisel yaralanmaları önlemek için çocukların ürüne tırmanmasına veya üzerinde durmasına izin vermeyiniz.

Herhangi bir bileşeni kırık veya eksikse lütfen ürünü kullanmayın, aksi takdirde hasar veya yaralanma meydana gelebilir.

Boğulma riskini önlemek için lütfen tüm parçaları ve ambalajı (film, plastik torba, köpük vb.) bebeklerden ve çocuklardan uzak tutun.

Yanlışlıkla devrilmenin neden olduğu kişisel yaralanmaları önlemek için ürün, ürünle birlikte verilen devrilme önleyici kit kullanılarak duvara sabitlenmelidir.

Dolap içindeki her bir raf maksimum 18.1 kg, üst yüzey ise maksimum 72.6 kg yük taşıma kapasitesine sahiptir. Lütfen ürünün üzerine fazla