

Full Face Rubber Expansion Joint

TECHNICAL PARAMETERS

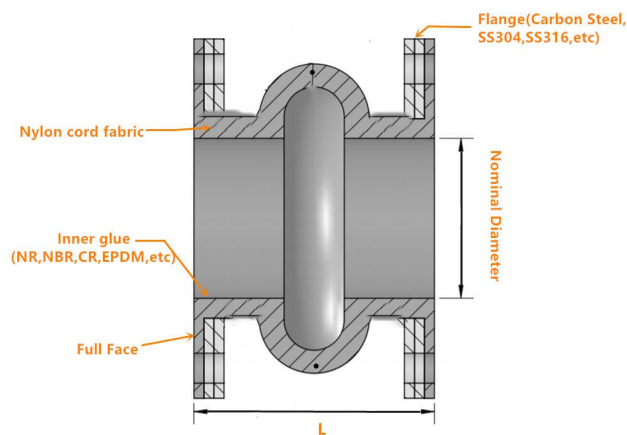

Item/ Model	1	2	3
Working pressure Mpa(kgf/cm ²)	1.0(10)	1.6 (16)	2.5 (25)
Explosive pressure Mpa (kgf/cm ²)	2.0 (20)	3.0 (30)	4.5 (45)
Vacuum Kpa (mm/Hg)	53.3 (400)	86.7 (650)	100 (750)
Applicable temperature °C	-15°C~+115°C special up to -30°C~+250°C		
Applicable medium	compressed air, water, sea water, hot water, oil, acid, etc		

Full face rubber expansion joint is also called large flanged flexible rubber joint, and the end face is fully sealed rubber joint. The product is characterized in that the flange and the end surface of the sphere are all in contact with each other, which not only increases the high pressure resistance of the product. It also played a good role in preventing pull-off.

MAIN DATA:

Nominal Diameter(DN)		Length	Axial displacement		Horizontal displacement	Angular deflection
mm	inch	mm	Extension(mm)	Compression(mm)	mm	(a1+a2)
32	1¼	95	6	9	9	15°
40	1½	95	6	10	9	15°
50	2	105	7	10	10	15°
65	2½	115	7	15	11	15°
80	3	135	8	19	12	15°
100	4	150	10	19	13	15°
125	5	165	12	20	13	15°
150	6	180	12	25	14	15°
200	8	210	16	25	22	15°
250	10	230	16	25	22	15°
300	12	245	16	25	22	15°
350	14	255	16	25	22	15°
400	16	255	16	25	22	15°
450	18	255	16	25	22	15°
500	20	255	16	25	22	15°
600	24	260	16	25	22	15°
700	28	260	16	25	22	15°
800	32	260	16	25	22	15°
900	36	260	16	25	22	15°
1000	40	260	18	26	24	15°
1200	48	260	18	26	24	15°
1400	56	350	20	28	26	15°
1600	64	350	25	35	30	10°
1800	72	350	25	35	30	10°
2000	80	420	25	35	30	10°
2200	88	420	25	35	30	10°
2400	96	420	25	35	30	10°
2600	104	450	25	35	30	10°
2800	112	450	25	35	30	10°
3000	120	500	25	35	30	10°

Notes:1.Please sent us letter and drawing for customization if you have special requirements.

2.Flange Standard :Flange is available with ANSI / JIS/ BS/ GB/ GOST Standard and so on.

 <p>河南顺赢新能源有限公司 Henan Shunying New Energy Co.,Ltd.</p>	Proposal/Inquiry/Order No:	NOTES:
	Customer Name:	
	Project Name:	
	Contractor:	